

SPEED QUEEN ON-PREMISES LAUNDRY

45 LB CAPACITY STT45

STACK TUMBLE DRYER

Stack Tumble Dryers

Our line of stack tumble dryers provides double the capacity of Speed Queen® single pocket tumble dryers while using only half the floor space. Plus, our patented oval cylinder perforations solve a common, highly damaging problem, by allowing stray screws to pass through without doing large amounts of damage to the dryer's sweep sheets.

- Large easy-to-clean lint compartment.
- Fewer moving parts mean fewer maintenance problems and less wear.
- Reversing option available.
- High-performance heater box increases energy efficiency, reduces drying times and provides a more comfortable operating environment.
- Axial airflow pattern with sealed cylinder rims delivers the fastest and most efficient drying results.
- Two drying pockets in the space of one unit helps increase drying capacity.
- Single gas, electric and exhaust hookups simplify installation and are less expensive than installing twice the number of single units.

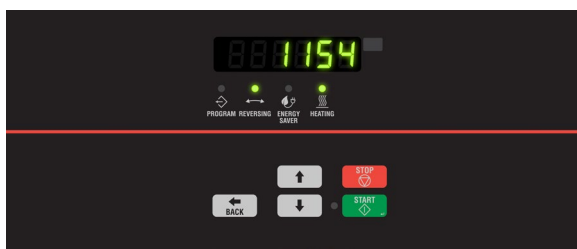

Quantum® Gold

Revolutionary Quantum® Gold technology combines equipment controls, programming and wireless networking into one complete OPL management system, giving you total control over your laundry room from any computer, anywhere in the world. Advanced diagnostics and audit data reports help you catch errors before they become bigger issues. Quantum Gold is designed to help you reduce costs, decrease your downtime and increase your throughput.

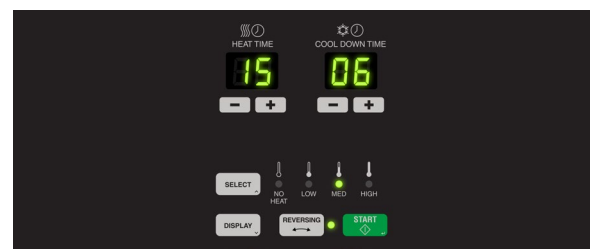

Dual Digital

With features that include one touch cycle repeat, automatic extended tumble and a large digital countdown display, it's simple to set your drying time, temperature and cool down on the fly.

SPECIFICATIONS

STACK TUMBLE DRYER

MODEL	STT45		
CONTROL OPTION	Quantum Gold, Dual Digital		
CAPACITY - lb (kg)	45 (20)		
OVERALL WIDTH - in (mm)	34.5 (875)		
OVERALL DEPTH - in (mm)	48.6 (1235)		
OVERALL HEIGHT - in (mm)	81.3 (2065)		
CYLINDER DIAMETER - in (mm)	33 (838)		
CYLINDER DEPTH - in (mm)	30 (762)		
CYLINDER VOLUME - cu. ft. (liters)	14.8 (420)		
REVERSING CYLINDER	Option		
DOOR OPENING SIZE - in (mm)	22.9 (581)		
ENERGY DATA	Gas Models - Per Pocket	95,000 x 2 Btu/hr	
GAS CONNECTIONS - in (npt)	0.5		
AIR OUTLET - in (mm)	1 x 10 (250)		
MOTOR - hp	2 x 0.5		
AIRFLOW - cfm	2x 600		
ELECTRICAL SPECS - amps	Gas		
	X	200-240V/50/60/1/3	12
	N	440-480V/50/60/3	6
	P	380-415V/50/60/3	6
SHIPPING DIMENSIONS	Width	35.5 (900)	
	Depth	54 (1370)	
	APPROX. - in (mm)	Height	84.9 (2160)
NET WEIGHT - lb (kg)	710 (320)		
SHIPPING WEIGHT - lb (kg)	750 (340)		
AGENCY APPROVALS	CSA		

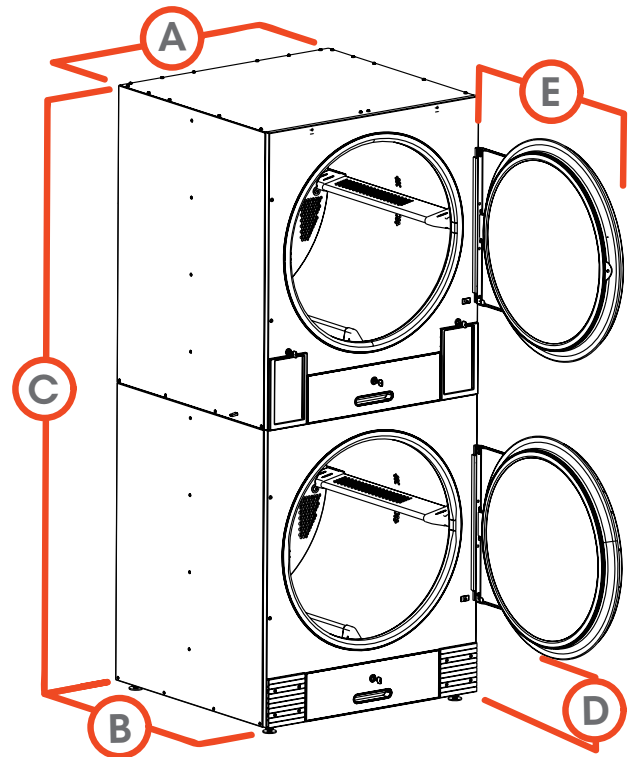

A.	OVERALL WIDTH - in (mm)	34.5 (875)
B.	OVERALL DEPTH - in (mm)	48.6 (1235)
C.	OVERALL HEIGHT - in (mm)	81.3 (2065)
D.	DOOR BOTTOM TO FLOOR - in (mm)	9.3 (235)
E.	DOOR SWING - in (mm)	31.9 (810)

Tumble dryer models are made to suit a variety of electrical service characteristics. See your Speed Queen distributor for specifications. For further details on installation, refer to Installation, Operation and Maintenance instructions supplied with the tumble dryer. Amperage ratings available in Installation Manual.

For the most accurate information, the installation guide should be used for all design and construction purposes. Due to continuous product improvements, design and specifications subject to change without notice. The quality management system of Alliance Laundry Systems' Ripon facility has been registered to ISO 9001:2008.