

VENDED  
SINGLE TUMBLE DRYER

PT050

PT075

50lb

75lb

PT  
RANGE



FEATURES

- Easy-to-use microprocessor control
- Electric, gas, and steam heating
- Large door opening for easy loading and unloading
- Patented cylinder holes allow drywall screws to pass through without damage
- Galvanized cylinder
- Radial airflow
- Large self-cleaning lint screen
- Standard activation: single coin drop

OPTIONS

- Available activations include: dual coin drop, electronic drop, prep for coin, prep for card reader, and prep for central pay
- Reversing cylinder to avoid tangling of large items
- Stainless steel cylinder
- Stainless steel front panel



FAST DRYING



EASY OPERATION



LARGE DOOR OPENING

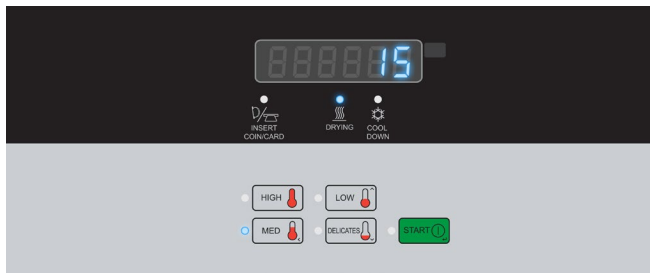

MODEL		PT050	PT075
CONTROL OPTION		XQ	XQ
CAPACITY - lb (kg)		50 (23)	75 (34)
OVERALL WIDTH - in (mm)		38.62 (981)	38.62 (981)
OVERALL DEPTH - in (mm)		29.5 (749)	35.5 (902)
OVERALL HEIGHT - in (mm)	Gas/Electric	76.62 (1946)	76.62 (1946)
	Steam	80 (2032)	80 (2032)
CYLINDER DIAMETER - in (mm)		37 (940)	37 (940)
CYLINDER VOLUME - cu. ft. (liters)		18.6 (527)	22.4 (634)
DOOR OPENING SIZE - in (mm)		26.88 (683)	26.88 (683)
ENERGY DATA	Steam Models - 100 psi	177,500 Btu/h	210,300 Btu/h
	Electric Models	30 kW	30 kW
	Gas Models	130,000 Btu/h	165,000 Btu/h
EXHAUST - in (mm)		8 (203)	8 (203)
GAS CONNECTIONS - in (npt)		0.75	0.75
STEAM CONNECTIONS - in (npt)		0.75	0.75
MOTOR - hp	Fan	0.5	0.75
	Drive	0.5	0.75
DRYING AVERAGE - lbs/min	Gas Heating	1	1.36
	Electric Heating	0.85	0.82
AIRFLOW - cfm	Gas/Steam	750	920
	Electric	750	750
ELECTRICAL SPECS - amps		Non Rev (Rev)	Non Rev (Rev)
GAS & STEAM	120/208-240/60/1 2W/3W+G	(12.0/6.5)	13 (13)
	120/60/1 2W+G	9.3	13.8
	200-208/240/60/1 2W+G	5.1/5.1	7.6/7.6
	200-208/240/60/3 3W+G	2.8/2.8 (4.0/4.0)	3.8/3.8 (4.3/4.3)
	380/60/3 3W+G	1.6 (2.0)	1.8 (2.1)
	Steam Only - 440/60/3 3W+G	1.4 (1.9)	1.9 (2.1)
	460-480/60/3 3W+G	1.4 (1.9)	1.9 (2.1)
ELECTRIC	200-208/60/3 3W+G	89 (88)	89 (88)
	240/60/3 3W+G	79 (78)	79 (78)
	380/60/3 3W+G	47 (48)	47 (48)
	440/60/3 3W+G	41 (41)	41 (41)
	480/60/3 3W+G	38 (38)	38 (38)
SHIPPING DIMENSIONS APPROX. - in (mm)	Width	41.5 (1054)	41.5 (1054)
	Depth	52.1 (1323)	56.4 (1433)
	Height	81 (2057)	81 (2057)
NET WEIGHT - lb (kg)		545 (247)	615 (279)
SHIPPING WEIGHT - lb (kg)		602 (273)	677 (307)
AGENCY APPROVALS		cCSAus	cCSAus

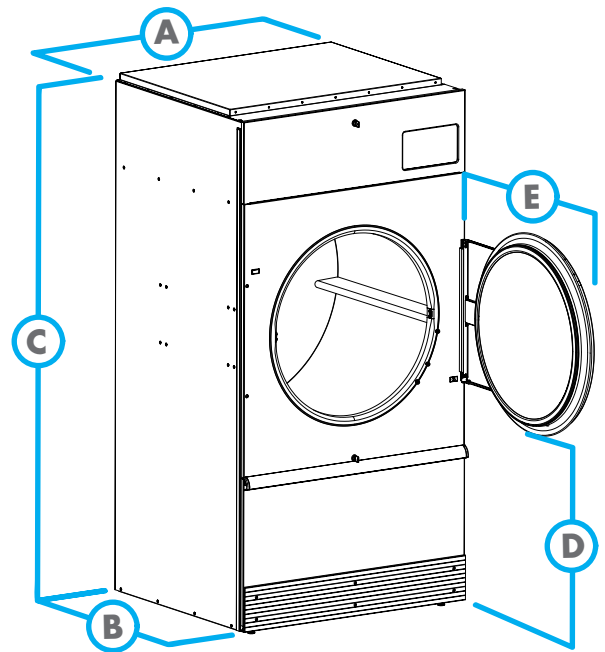

DIMENSIONS		PT050	PT075
A.	OVERALL WIDTH - in (mm)	38.62 (981)	38.62 (981)
B.	OVERALL DEPTH - in (mm)	29.5 (749)	35.5 (902)
C.	OVERALL HEIGHT - in (mm)	Gas/Electric	76.62 (1946)
		Steam	80 (2032)
D.	DOOR BOTTOM TO FLOOR - in (mm)	30.75 (781)	30.75 (781)
E.	DOOR SWING - in (mm)	33.88 (860)	33.88 (860)

AY18-0056

For the most accurate information, the installation guide should be used for all design and construction purposes. Due to continuous product improvements, design and specifications subject to change without notice. The quality management system of Alliance Laundry Systems' Ripon facility has been registered to ISO 9001:2008.

© 2018 Alliance Laundry Systems LLC

[www.primuslaundry.com](http://www.primuslaundry.com)

**primus**

by Alliance Laundry Systems