

STACK WASHER/DRYER

(ELECTRIC/GAS)

Speed Queen®

RENOWNED FOR COMMERCIAL-GRADE CONSTRUCTION.



FULL-SIZE CAPACITY WASHER AND DRYER

- Fits large loads
- Utilizes vertical space
- Delivers superior washability and more efficient drying

COMMERCIAL, HEAVY-DUTY SUSPENSION SYSTEM (WASHER)

- Constructed with four commercial, heavy-duty shock absorbers
- Adds strength and durability
- Limits out-of-balance issues

VARIABLE-SPEED INDUCTION MOTOR WITH INVERTER DRIVE (WASHER)

- 300 G-Force and 1000 RPM spin speed optimizes water extraction and performance

GALVANIZED STEEL CYLINDER (DRYER)

- Won't corrode, chip or crack

QUIET, HIGHLY EFFICIENT BLOWER (DRYER)

- Superior airflow of 220 cfm for faster drying

INDUSTRY-LEADING, TRANSFERRABLE WARRANTY

- Three years parts & labor
- 5 years on motor & cabinet*
- Lifetime on all stainless steel washtubs and outer draintubs

* Limited. See Speed Queen warranty bond for details.



STACK WASHER/DRYER SPECIFICATIONS

Washer Model	Electric: Gas:	ATE50F/ATG50F	Dryer Model	Electric: Gas:	ATE50F/ATG50F
Color: White	✓		Color: White	✓	
2.84 cu.ft. Stainless Steel WashTub	✓		Commercial Steel Cylinder	✓	
3 Stainless Steel Baffles	✓		Secured Lint Filter	✓	
Stainless Steel Outer Draintub	✓		Door Windows	✓	
15 1/2" Door Opening	✓		Galvanized Steel Cabinet	✓	
10" Stainless Steel Hinge	✓		Extra-Large Door Opening (2.06 sq. ft.)	✓	
Galvanized Steel Cabinet	✓		Front Controls	✓	
Front Controls	✓		Drum Capacity - cu. ft.	7	
Tub Volume - cu. ft.	2.84		Electrical Requirements (Electric) Breaker Size	240V/60 HzAC/1 Ph 30 Amp	
Electrical Requirements Breaker Size	120V/60 HzAC 15 Amp		Electrical Requirements (Gas) Breaker Size	120V/60 HzAC/1 Ph 15 Amp	
Motor HP	1		Electric Heating Wattage	5350	
Spin Speeds - RPM	500, 650, 1000		Gas Consumption - Btu	22,500	
300 G-Force High Speed Water Extraction	✓		Motor HP	1/3	
Variable Speed Induction Motor	✓		Automatic Dry Cycles	✓	
5,499 Cylinder Holes	✓		Heavy-Duty 220 cfm Exhaust Fan	✓	
Extra Rinse	✓		Quiet, Efficient Blower	✓	
Cycle Indicator Light	✓		Cycles	3	
Three Compartment Solution Dispenser	✓		Multiple Vent Kit	528P3	
Cycles	8		LP Conversion Kit	649P3	
Average Water Consumption - Gallons	13.9		Dryer Rack	512082P	
Stack Unit					
Overall Dimensions H x W x D -	75 1/4" x 26 7/8" x 28"				
Approximate Shipping Weight - lb	380 electric model 385 gas model				
Agency Approvals	cULus, CSAus Star, MA Gas Board				

ATE50F/ATG50F
ENERGY STAR® Qualified Washer, Quiet, Efficient Blower, Automatic Dry Cycles, Extra Rinse

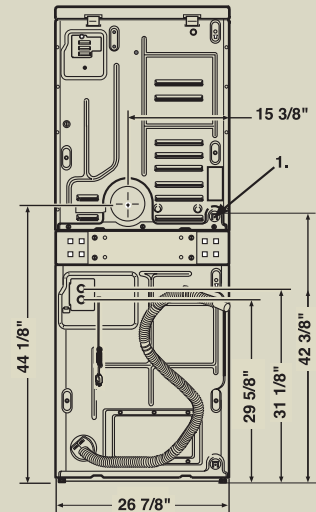
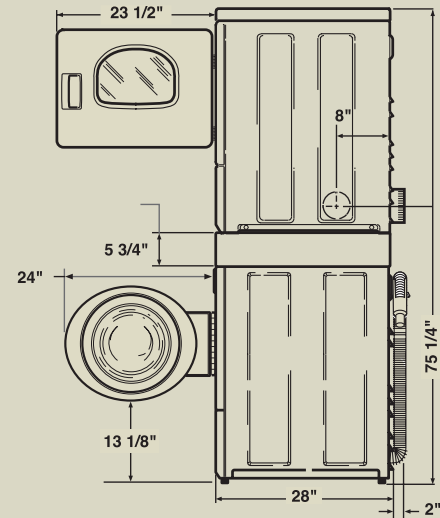
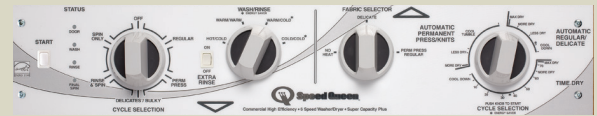

1. 3/8 in. NPT Gas Connection

SWD829N
SWD830N

Made in America since 1908, Speed Queen machines are renowned for their consistently powerful performance. Whether designed for homeowners or for commercial laundries, our washers and dryers are built to the highest standards of durability and dependability – and backed by superior customer service.

For the most accurate information, the installation guide should be used for all design and construction purposes. Due to continuous product improvements, design and specifications are subject to change without notice. The quality management system of Alliance Laundry Systems' Ripon facility has been registered to ISO 9001:2000. Printed in the USA.

speedqueen.com

