

DRYERS AND STACK DRYERS

(ELECTRIC/GAS)

Speed Queen®

RENOWNED FOR COMMERCIAL-GRADE CONSTRUCTION.



EXTRA-LARGE CYLINDER CAPACITY

- Means large loads aren't a problem. The 18lb capacity 7.0 cu. Ft. cylinder delivers superior tumble action and more efficient drying

GALVANIZED STEEL CYLINDER

- With Commercial galvanized steel interior that won't corrode, chip or crack

LARGEST DOOR OPENING IN THE INDUSTRY

- Measures 2.06 sq ft making loading and unloading easier

QUIET, HIGHLY EFFICIENT BLOWER

- Superior airflow of 220 cfm for faster drying

INDUSTRY LEADING TRANSFERRABLE WARRANTY

- Three years Parts & Labor
- 5 Years on motor & cabinet*
- 10 Years on transmission
- Lifetime on all stainless steel washtubs and outer draitubs.*
- *Limited, See speed Queen warranty bond for details



SINGLE AND STACK **DRYER** SPECIFICATIONS

Model	Electric: Gas:	ADE4BF ADG4BF	ADE4BR ADG4BR	ADE3LR ADG3LR	ADE3OR ADG3OR	ASE30F ASG30F (Stack)
Color: White		✓	✓	✓	✓	✓
Front Controls		✓				✓
Rear Controls			✓	✓	✓	
Commercial Steel Cylinder		✓	✓	✓	✓	✓
Secured Lint Filter		✓	✓	✓	✓	✓
Cylinder Light		✓	✓	✓		
Reversible Door		✓	✓	✓	✓	
Door Windows						✓
Galvanized Steel Cabinet		✓	✓	✓	✓	✓
Extra-Large Door Opening (2.06 sq. ft.)		✓	✓	✓	✓	✓
Drum Capacity - cu. ft.		7	7	7	7	7 each (14 total)
Overall Dimensions - H x W x D		41 3/8" x 26 7/8" x 28"	43" x 26 7/8" x 28"		43" x 26 7/8" x 28"	75 1/4" x 26 7/8" x 28"
Work Surface Height - in		41 3/8"	36"	36"	36"	N/A
Approximate Shipping Weight - lb		155 electric model 160 gas model	140 electric model 145 gas model		140 electric model 145 gas model	255 electric model 265 gas model
Electrical Requirements (Electric) Breaker Size		240V/60 HzAC/1 Ph 30 Amp	240V/60 HzAC/1 Ph 30 Amp		240V/60 HzAC/1 Ph 30 Amp	2 x 240V/60 HzAC/1 Ph 2 x 30 Amp
Electrical Requirements (Gas) Breaker Size		120V/60 HzAC/1 Ph 15 Amp	120V/60 HzAC/1 Ph 15 Amp		120V/60 HzAC/1 Ph 15 Amp	2 x 120V/60 HzAC/1 Ph 2 x 15 Amp
Electric Heating Wattage		5350	5350	5350	5350	5350 per pocket
Gas Consumption - Btu		22,500	22,500	22,500	22,500	22,500 per pocket
Motor HP		1/3	1/3	1/3	1/3	2 x 1/3
Automatic Dry Cycles		✓	✓	✓	✓	✓
Multiple Vent Options		✓	✓	✓	✓	✓
Heavy-Duty 220 cfm Exhaust Fan		✓	✓	✓	✓	✓
Quiet, Efficient Blower		✓	✓	✓	✓	✓
Adjustable End-of-Cycle Buzzer		✓	✓	✓		
Extended Tumble		✓	✓			
ADA Compliant		✓				✓ (lower dryer)
Cycles		4	4	3	3	3 (each dryer)
Multiple Vent Kit		528P3	528P3	528P3	528P3	528P3
LP Conversion Kit		649P3	649P3	649P3	649P3	649P3
Dryer Rack		included	included	512082P	512082P	512082P
Agency Approvals		UL, CSA Star, MA Gas Board	UL, CSA Star, MA Gas Board		UL, CSA Star, MA Gas Board	UL, CSA Star, MA Gas Board

ADE4BR/ADG4BR (Shown on front)
4 Cycles, Adjustable End-of-Cycle Buzzer, Extended Tumble, Dryer
Rack, Auto Dry Cycles



ADE3LR/ADG3LR
3 Cycles, Adjustable End-of-Cycle Buzzer, Auto Dry Cycles



ADE3OR/ADG3OR
3 Cycles, Auto Dry Cycles



ADE4BF/ADG4BF (Front Control)
4 Cycles, Adjustable End-of-Cycle Buzzer, Extended Tumble,
ADA Compliant, Dryer Rack, Auto Dry Cycles



ASE30F/ASG30F (Stack Dryer/Dryer)
3 Cycles, ADA Compliant (lower dryer), Auto Dry Cycles



Rear control only

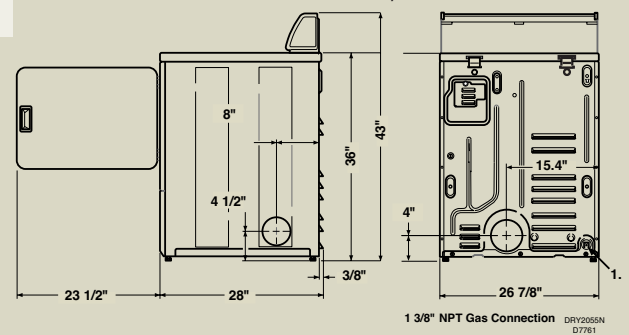

Speed Queen washers and dryers have long been the favorite of commercial laundries. Speed Queen washers and dryers are built for top performance in the commercial industry, but now they are available for your home. Speed Queen offers a variety of washers and dryers to fit the needs of any household. Our home laundry products deliver utility-saving features and user-friendly controls along with Speed Queen's famous durability.

With over 100 years of commercial quality laundry equipment experience, our expertise in no-nonsense design and performance-based construction assures our customers that their purchase will include the performance features they want and the durability that make Speed Queen stand above the competition

For the most accurate information, the installation guide should be used for all design and construction purposes. Due to continuous product improvements, design and specifications are subject to change without notice. The quality management system of Alliance Laundry Systems' Ripon facility has been registered to ISO 9001:2000. Printed in the USA.

speedqueen.com

