

FRONT LOAD WASHERS

Speed Queen®

RENOWNED FOR COMMERCIAL-GRADE CONSTRUCTION.



EXTRA-LARGE 2.84 CU. FT. STAINLESS STEEL INNER AND OUTER TUB

- Constructed for increased washing performance and higher water extraction
- Saves energy, time and money

EXTRA-LARGE 15.5" DOOR OPENING

- Allows easy loading and unloading

COMMERCIAL, HEAVY-DUTY SUSPENSION SYSTEM

- Constructed with four commercial, heavy-duty shock absorbers
- Adds strength and durability
- Limits out-of-balance issues

DOOR OPENING HIGHER THAN NON-PEDESTAL COMPETITIVE MODELS

- Easier to load and unload clothes

VARIABLE-SPEED INDUCTION MOTOR WITH INVERTER DRIVE

- Offers a 300 G-Force and 1000 RPM spin speed for optimum water extraction and outstanding performance

THREE-COAT, COMMERCIAL-GRADE STEEL CABINET

- Constructed with a galvanized metal cabinet and an extra E coat dip before the final paint for a long-lasting finish



INDUSTRY-LEADING, TRANSFERRABLE WARRANTY

- Three years parts & labor
- 5 years on motor & cabinet bearing and assembly*

* Limited. See Speed Queen warranty bond for details.



FRONT LOAD WASHER SPECIFICATIONS

Model	AFN50F 	AFN50R 
Color: White	✓	✓
3 Stainless Steel Baffles	✓	✓
Stainless Steel Outer Draintub	✓	✓
15 1/2" Door Opening	✓	✓
10" Stainless Steel Hinge	✓	✓
Galvanized Steel Cabinet	✓	✓
Front Controls	✓	
Rear Controls		✓
Stainless Steel Wash tub Volume - cu. ft.	2.84	2.84
Overall Dimensions - H x W x D	41 3/8" x 26 7/8" x 28"	43" x 26 7/8" x 28"
Work Surface Height - in	41 3/8"	36"
Approximate Shipping Weight - lb	260	250
Electrical Requirements Breaker Size	120V/60 HzAC 15 Amp	120V/60 HzAC 15 Amp
Motor HP	1	1
Spin Speeds - RPM	500, 650, 1000	500, 650, 1000
Fill Hoses Included	✓	✓
ADA Compliant	✓	✓
300 G-Force High Speed Water Extraction	✓	✓
Variable Speed Induction Motor	✓	✓
5,499 Cylinder Holes	✓	✓
Tuff Guard Coated Top	✓	✓
Extra Rinse Option	✓	✓
Cycle Indicator Light	✓	✓
Three Compartment Solution Dispenser	✓	✓
Cycles	8	8
Average Water Consumption - Gallons	10.3	10.3
Agency Approvals	cULus	cULus

AFN50F (Shown on front) – 8 Cycles, ADA Compliant, ENERGY STAR® Qualified, Front Control

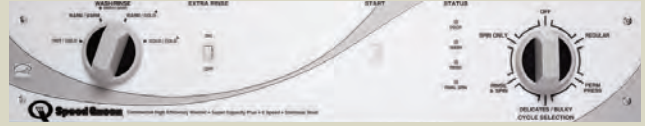

AFN50R – 8 Cycles, ADA Compliant, ENERGY STAR® Qualified, Rear Control

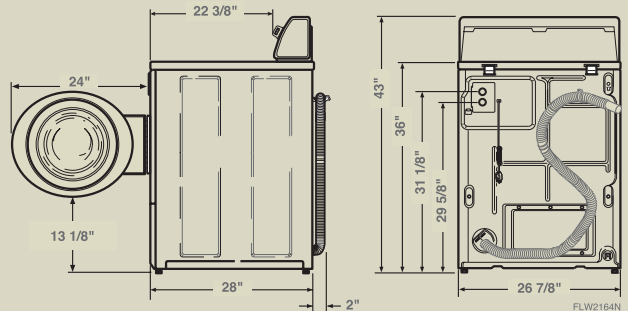
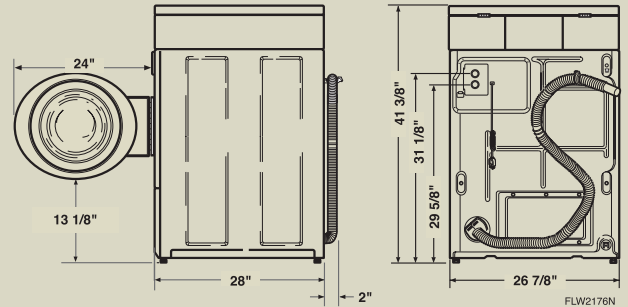

AFN50R – Rear Control Model



Made in America since 1908, Speed Queen machines are renowned for their consistently powerful performance. Whether designed for homeowners or for commercial laundries, our washers and dryers are built to the highest standards of durability and dependability – and backed by superior customer service.

For the most accurate information, the installation guide should be used for all design and construction purposes. Due to continuous product improvements, design and specifications are subject to change without notice. The quality management system of Alliance Laundry Systems' Ripon facility has been registered to ISO 9001:2000. Printed in the USA.

speedqueen.com

