

# Tumble Dryers

25 Pound (11 Kilogram) Capacity

30 Pound (13 Kilogram) Capacity

35 Pound (16 Kilogram) Capacity

Stacked 30 Pound (13/13 Kilogram) Capacity

Stacked 45 Pound (20/20 Kilogram) Capacity

55 Pound (24 Kilogram) Capacity

15 Digit Model Numbers with 2 in 12th Position

Refer to Page 10 for Model Identification

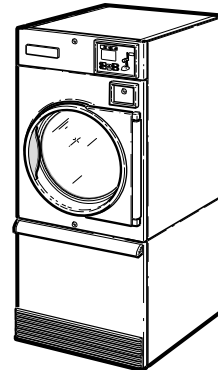
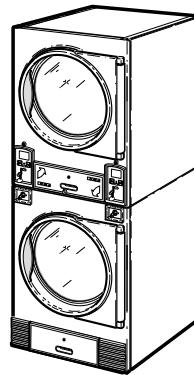

TMB1278C\_SVG

## Original Instructions

Keep These Instructions for Future Reference.

**CAUTION:** Read the instructions before using the machine.

(If this machine changes ownership, this manual must accompany machine.)



Installation must conform with local codes or, in the absence of local codes, with:

In the U.S.A., installation must conform to the latest edition of the American National Standard Z223.1/ NFPA 54 “National Fuel Gas Code” and Standard ANSI/NFPA 70 “National Electric Code.”

In Canada, installation must comply with Standards CAN/CSA-B149.1 or Natural Gas and Propane Installation Code and CSA C22.1, latest edition, Canadian Electric Code, Part I.

In Australia and New Zealand, installation must comply with the Gas Installations Standard AS/NZS 5601 Part 1: General Installations.



## WARNING

**FOR YOUR SAFETY, the information in this manual must be followed to minimize the risk of fire or explosion or to prevent property damage, personal injury or death.**

W033



## WARNING

- Do not store or use gasoline or other flammable vapors and liquids in the vicinity of this or any other appliance.
- **WHAT TO DO IF YOU SMELL GAS:**
  - Do not try to light any appliance.
  - Do not touch any electrical switch; do not use any phone in your building.
  - Clear the room, building or area of all occupants.
  - Immediately call your gas supplier from a neighbor’s phone. Follow the gas supplier’s instructions.
  - If you cannot reach your gas supplier, call the fire department.
- Installation and service must be performed by a qualified installer, service agency or the gas supplier.

W052

**IMPORTANT:** Information must be obtained from a local gas supplier on instructions to be followed if the user smells gas. These instructions must be posted in a prominent location. Step-by-step instructions of the above safety information must be posted in a prominent location near the tumble dryer for customer use.

**IMPORTANT:** The installer must fully test the tumble dryer after installation and demonstrate to the owner how to operate the machine.



## WARNING

**To reduce the risk of electric shock, fire, explosion, serious injury or death:**

- Disconnect electric power to the tumble dryer before servicing.
- Close gas shut-off valve to gas tumble dryer before servicing.
- Close steam valve to steam tumble dryer before servicing.
- Never start the tumble dryer with any guards/panels removed.
- Whenever ground wires are removed during servicing, these ground wires must be reconnected to ensure that the tumble dryer is properly grounded.

W002R1



## WARNING

- **Installation of unit must be performed by a qualified installer.**
- **Install tumble dryer according to manufacturer's instructions and local codes.**
- **DO NOT install a tumble dryer with flexible plastic venting materials. If flexible metal (foil type) duct is installed, it must be of a specific type identified by the appliance manufacturer as suitable for use with tumble dryer. Refer to section on connecting exhaust system. Flexible venting materials are known to collapse, be easily crushed, and trap lint. These conditions will obstruct tumble dryer airflow and increase the risk of fire.**

W752R1

The following information applies to the state of Massachusetts, USA.

- This appliance can only be installed by a Massachusetts licensed plumber or gas fitter.
- This appliance must be installed with a 36 inch [91 cm] long flexible gas connector.
- A "T-Handle" type gas shut-off valve must be installed in the gas supply line to this appliance.
- This appliance must not be installed in a bedroom or bathroom.

# Table of Contents

<b>Introduction.....</b>	<b>9</b>
Model Identification.....	9
Contact Information.....	16
Manufacturing Date .....	17
Manufacturing Date.....	17
<b>Safety Information.....</b>	<b>18</b>
Explanation of Safety Messages.....	18
Important Safety Instructions.....	18
<b>Specifications and Dimensions.....</b>	<b>20</b>
Specifications and Dimensions.....	20
Cabinet Dimensions – 025, 030, 035 and 055 Series.....	24
Cabinet Dimensions – T30 and T45 Series.....	26
Exhaust Outlet Locations – 025, 030, 035 and 055 Series.....	27
Exhaust Outlet Locations – T30 and T45 Series.....	28
Gas Connection Locations – 025, 030, 035 and 055 Series.....	29
Gas Connection Locations – T30 and T45 Series.....	31
Electrical Connection Locations – 025, 030, 035 and 055 Series.....	32
Electrical Connection Locations – T30 and T45 Series.....	33
Steam Connection Locations – 025, 030 and 035 Series.....	34
Steam Connection Locations – T30 Series.....	35
<b>Installation.....</b>	<b>36</b>
Pre-Installation Inspection.....	36
Location Requirements.....	36
Position and Level the Tumble Dryer.....	37
Fifth Leveling Leg.....	38
Fire Suppression System (Optional Equipment).....	38
Check Local Codes and Permits.....	38
Water Requirements.....	38
Water Connections.....	39
Electrical Requirements.....	40
Auxiliary Alarm.....	40
To Reverse the Loading Door (025, 030, 035 and 055 Series).....	40
Before Placing Tumble Dryer into Service.....	42
Required for CE Models Only.....	44
Installing CE Gas Drying Tumble Dryer.....	44
General Information.....	44
CE Orifices.....	45
Properties of CE Gases.....	48

© Published by permission of the copyright owner.

All rights reserved. No part of the contents of this book may be reproduced or transmitted in any form or by any means without the expressed written consent of the publisher.

Changing Gas Configuration.....	49
Specific Conversion Procedures.....	50
<b>Exhaust Requirements.....</b>	<b>53</b>
Exhaust Requirements.....	53
Layout.....	53
Make-Up Air.....	53
Venting.....	53
Individual Venting.....	55
Manifold Venting.....	56
<b>Gas Requirements.....</b>	<b>59</b>
Gas Requirements.....	59
Gas Supply Pipe Sizing and Looping.....	61
Low Pressure Gas Pipe Sizes.....	62
High Pressure Gas Pipe Sizes.....	64
High Altitude Burner Orifice Sizing.....	65
<b>Electrical Requirements.....</b>	<b>73</b>
Electrical Requirements.....	73
Wiring Diagram.....	73
Wiring for Central Pay.....	73
Grounding Instructions.....	75
For CE Models Only.....	75
Service/Ground Location.....	75
To Connect Electrical Service To The Tumble Dryer.....	79
Configuring Your Tumble Dryer for Other Service Voltages.....	79
Electrical Connections for T30 and T45 Only.....	80
Conversion Instructions.....	81
Ferrite Ring Installation (025, 030, 035 and 055 Series Only).....	82
Electrical Specifications.....	83
<b>Steam Requirements.....</b>	<b>95</b>
Steam Requirements.....	95
Piping Recommendations.....	97
Installing Steam Trap and Making Condensate Return Connections.....	97
<b>Single Drop Timer.....</b>	<b>98</b>
Power-Up Mode.....	98
Ready Mode.....	98
Start Mode.....	98
Run Mode.....	98
Door Open Mode.....	98
End of Cycle Mode.....	98
Setting Dry Time Dipswitches.....	98
Models Through Serial No. 0908xxxxx.....	98
Models Starting Serial No. 0909xxxxx.....	98
Resetting Cycle Time to Zero.....	98

Dipswitch Settings.....	99
Topoffs.....	102
Temperature Selector Switch.....	102
To Program a Short Test Cycle.....	102
Error Codes.....	102
<b>Operating Instructions.....</b>	<b>103</b>
Operating Instructions.....	103
Emergency Stop Button On CE Models.....	103
Operating Instructions.....	103
Reversing Operation.....	104
Control Instructions.....	104
Dual Digital Timer Control.....	104
Electronic OPL Micro Control.....	106
Single Drop Control.....	107
MDC Coin and Card Control.....	108
Quantum Control .....	108
Galaxy 600 Control .....	109
LED OPL Control .....	110
UniLinc Control .....	111
DX4 Coin Control.....	112
DX4 OPL Control.....	113
Diagnostic Microprocessor Control .....	113
DMP OPL Models.....	115
DMP Coin.....	117
Ignition Control Operation and Troubleshooting for Models Starting 3/11/13....	119
Internal Control Failure.....	119
Troubleshooting.....	119
Proper Electrode Location.....	120
Flame Current Measurement.....	120
Ignition Control Operation for Non-CE Models Through 3/10/13.....	120
Ignition Control Operation for CE Models Through 3/10/13.....	121
System Tests.....	121
Diagnostic LED (DGN LED)/Error Codes.....	122
<b>Adjustments.....</b>	<b>123</b>
Adjustments.....	123
Gas Burner Air Shutter.....	123
Airflow Switch .....	124
Loading Door Switch.....	124
Door Strike.....	125
<b>Maintenance.....</b>	<b>126</b>
Daily.....	126
Monthly.....	127
Quarterly.....	127
Bi-Annually.....	127
Annually.....	127
Fire Suppression System (Optional Equipment) Maintenance Test.....	127

**Before You Call for Service..... 129**

**Removing Tumble Dryer from Service..... 130**

**Disposal of Unit.....131**

**China Restriction of hazardous substances (RoHS)..... 132**



# Introduction

## Model Identification

Information in this manual is applicable to these models. **Refer to the machine serial plate for the model number.**

	Gas			Steam		Electric	
025 Series (11 Kg)	BA025L	HT025R	PU025N	BH025S	NT025S	BH025E	MT025F
	BA025N	HU025L	SA025L	BT025S	NU025S	BH025F	NH025E
	BH025L	HU025N	SA025N	BU025S	PH025S	BT025E	NT025E
	BH025N	HU025R	SH025L	CT025S	PT025S	BT025F	NU025E
	BH025R	IT025L	SH025N	CU025S	PU025S	BU025E	PH025E
	BK025N	IT025N	SH025R	HH025S	SH025S	BU025F	PT025E
	BK025R	IT025R	SK025N	HT025S	ST025S	CT025E	PU025E
	BT025L	LA025L	SK025R	HU025S	SU025S	CT025F	SH025E
	BT025N	LA025N	ST025L	IT025S	UH025S	CU025E	SH025F
	BT025R	LK025N	ST025N	LT025S	UT025S	CU025F	ST025E
	BU025L	LT025L	ST025R	LU025S	UU025S	HH025E	ST025F
	BU025N	LT025N	SU025L	MT025S	YT025S	HH025F	SU025E
	BU025R	LU025L	SU025N	NH025S	YU025S	HT025E	SU025F
	CA025L	LU025N	SU025R			HT025F	UH025E
	CA025N	MT025L	UA025L			HU025E	UH025F
	CK025N	MT025N	UA025N			HU025F	UT025E
	CK025R	MT025R	UH025L			IT025E	UT025F
	CT025L	NH025L	UH025N			IT025F	UU025E
	CT025N	NH025N	UH025R			LT025E	UU025F
	CT025R	NT025L	UK025N			LU025E	YT025E
	CU025L	NT025N	UK025R			MT025E	YU025E
	CU025N	NU025L	UT025L				
	CU025R	NU025N	UT025N				
	HA025L	PA025L	UT025R				
	HA025N	PA025N	UU025L				
	HH025L	PH025L	UU025N				
	HH025N	PH025N	UU025R				
	HH025R	PK025N	YT025L				
	HK025N	PT025L	YT025N				
	HK025R	PT025N	YU025L				
	HT025L	PU025L	YU025N				
	HT025N						

*Table continues...*

	Gas			Steam		Electric	
030 Series (13 Kg)	BA030L	HT030N	PU030N	BH030S	NT030S	BH030E	MT030F
	BA030N	HT030R	SA030L	BT030S	NU030S	BH030F	NH030E
	BH030L	HU030L	SA030N	BU030S	PH030S	BT030E	NT030E
	BH030N	HU030N	SH030L	CT030S	PT030S	BT030F	NU030E
	BH030R	HU030R	SH030N	CU030S	PU030S	BU030E	PH030E
	BK030N	IT030L	SH030R	HH030S	SH030S	BU030F	PT030E
	BK030R	IT030N	SK030N	HT030S	ST030S	CT030E	PU030E
	BT030D	IT030R	SK030R	HU030S	SU030S	CT030F	SH030E
	BT030L	LA030L	ST030D	IT030S	UH030S	CU030E	SH030F
	BT030N	LA030N	ST030L	LT030S	UT030S	CU030F	ST030E
	BT030R	LK030N	ST030N	LU030S	UU030S	HH030E	ST030F
	BU030L	LT030L	ST030R	MT030S	YT030S	HH030F	SU030E
	BU030N	LT030N	SU030L	NH030S	YU030S	HT030E	SU030F
	BU030R	LU030L	SU030N			HT030F	UH030E
	CA030L	LU030N	SU030R			HU030E	UH030F
	CA030N	MT030L	UA030L			HU030F	UT030E
	CK030N	MT030N	UA030N			IT030E	UT030F
	CK030R	MT030R	UH030L			IT030F	UU030E
	CT030L	NH030L	UH030N			LT030E	UU030F
	CT030N	NH030N	UH030R			LU030E	YT030E
	CT030R	NT030L	UK030N			MT030E	YU030E
	CU030L	NT030N	UK030R				
	CU030N	NU030L	UT030L				
	CU030R	NU030N	UT030N				
	HA030L	PA030L	UT030R				
	HA030N	PA030N	UU030L				
	HH030L	PH030L	UU030N				
	HH030N	PH030N	UU030R				
	HH030R	PK030N	YT030L				
	HK030N	PT030L	YT030N				
	HK030R	PT030N	YU030L				
	HT030D	PU030L	YU030N				
	HT030L						

Table continues...

	Gas			Steam		Electric		
T30 Series (13/13 Kg)	BAT30L	HTT30R	PUT30L	BHT30S	NHT30S	BHT30E	MTT30F	
	BAT30N	HUT30L	PUT30N	BTT30S	NTT30S	BHT30F	NHT30E	
	BHT30L	HUT30N	SAT30L	BUT30S	NUT30S	BTT30E	NTT30E	
	BHT30N	HUT30R	SAT30N	CTT30S	PHT30S	BTT30F	NUT30E	
	BHT30R	ITT30L	SHT30L	CUT30S	PTT30S	BUT30E	PHT30E	
	BKT30N	ITT30N	SHT30N	HHT30S	PUT30S	BUT30F	PTT30E	
	BKT30R	ITT30R	SHT30R	HTT30S	SHT30S	CTT30E	PUT30E	
	BTT30D	LAT30L	SKT30N	HUT30S	STT30S	CUT30E	SHT30E	
	BTT30L	LAT30N	SKT30R	ITT30S	SUT30S	HHT30E	SHT30F	
	BTT30N	LKT30N	STT30D	LTT30S	UHT30S	HHT30F	STT30E	
	BTT30R	LTT30L	STT30L	LUT30S	UTT30S	HTT30E	STT30F	
	BUT30L	LTT30N	STT30N	MTT30S	UUT30S	HTT30F	SUT30E	
	BUT30N	LUT30L	STT30R			HUT30E	SUT30F	
	BUT30R	LUT30N	SUT30L			HUT30F	UHT30E	
	CAT30L	MTT30L	SUT30N			ITT30E	UHT30F	
	CAT30N	MTT30N	SUT30R			ITT30F	UTT30E	
	CTT30L	MTT30R	UAT30L			LTT30E	UTT30F	
	CTT30N	NHT30L	UAT30N			LUT30E	UUT30E	
	CUT30L	NHT30N	UHT30L			MTT30E	UUT30F	
	CUT30N	NTT30L	UHT30N					
	HAT30L	NTT30N	UHT30R					
	HAT30N	NUT30L	UKT30N					
	HHT30L	NUT30N	UKT30R					
	HHT30N	PAT30L	UTT30L					
	HHT30R	PAT30N	UTT30N					
	HKT30N	PHT30L	UTT30R					
	HKT30R	PHT30N	UUT30L					
	HTT30D	PKT30N	UUT30N					
	HTT30L	PTT30L	UUT30R					
	HTT30N	PTT30N						
	NTT30N_SERIAL_THROUGH_0904							

Table continues...

	Gas			Steam		Electric	
035 Series (16 Kg)	BA035L	HT035R	PU035N	BH035S	NT035S	BH035E	MT035F
	BA035N	HU035L	SA035L	BT035S	NU035S	BH035F	NH035E
	BH035L	HU035N	SA035N	BU035S	PH035S	BT035E	NT035E
	BH035N	HU035R	SH035L	CT035S	PT035S	BT035F	NU035E
	BH035R	IT035L	SH035N	CU035S	PU035S	BU035E	PH035E
	BK035N	IT035N	SH035R	HH035S	SH035S	BU035F	PT035E
	BK035R	IT035R	SK035N	HT035S	ST035S	CT035E	PU035E
	BT035L	LA035L	SK035R	HU035S	SU035S	CT035F	SH035E
	BT035N	LA035N	ST035L	IT035S	UH035S	CU035E	SH035F
	BT035R	LK035N	ST035N	LT035S	UT035S	CU035F	ST035E
	BU035L	LT035L	ST035R	LU035S	UU035S	HH035E	ST035F
	BU035N	LT035N	SU035L	MT035S	YT035S	HH035F	SU035E
	BU035R	LU035L	SU035N	NH035S	YU035S	HT035E	SU035F
	CA035L	LU035N	SU035R			HT035F	UH035E
	CA035N	MT035L	UA035L			HU035E	UH035F
	CK035N	MT035N	UA035N			HU035F	UT035E
	CK035R	MT035R	UH035L			IT035E	UT035F
	CT035L	NH035L	UH035N			IT035F	UU035E
	CT035N	NH035N	UH035R			LT035E	UU035F
	CT035R	NT035L	UK035N			LU035E	YT035E
	CU035L	NT035N	UK035R			MT035E	YU035E
	CU035N	NU035L	UT035L				
	CU035R	NU035N	UT035N				
	HA035L	PA035L	UT035R				
	HA035N	PA035N	UU035L				
	HH035L	PH035L	UU035N				
	HH035N	PH035N	UU035R				
	HH035R	PK035N	YT035L				
	HK035N	PT035L	YT035N				
	HK035R	PT035N	YU035L				
	HT035L	PU035L	YU035N				
	HT035N						

Table continues...

	Gas			Steam	Electric	
T45 Series (20/20 Kg)	BAT45L	ITT45L	SAT45L	Not Applicable	Not Applicable	
	BAT45N	ITT45N	SAT45N			
	BHT45L	ITT45R	SHT45L			
	BHT45N	LAT45L	SHT45N			
	BHT45R	LAT45N	SHT45R			
	BKT45N	LKT45N	SKT45N			
	BKT45R	LTT45L	SKT45R			
	BTT45D	LTT45N	STT45D			
	BTT45L	LUT45L	STT45L			
	BTT45N	LUT45N	STT45N			
	BTT45R	MTT45L	STT45R			
	BUT45L	MTT45N	SUT45L			
	BUT45N	MTT45R	SUT45N			
	BUT45R	NHT45L	SUT45R			
	HAT45L	NHT45N	UAT45L			
	HAT45N	NTT45L	UAT45N			
	HHT45L	NTT45N	UHT45L			
	HHT45N	NUT45L	UHT45N			
	HHT45R	NUT45N	UHT45R			
	HKT45N	PAT45L	UKT45N			
	HKT45R	PAT45N	UKT45R			
	HTT45D	PHT45L	UTT45L			
	HTT45L	PHT45N	UTT45N			
	HTT45N	PKT45N	UTT45R			
	HTT45R	PTT45L	UUT45L			
	HUT45L	PTT45N	UUT45N			
	HUT45N	PUT45L	UUT45R			
	HUT45R	PUT45N				
	NTT45N_SERIAL_THROUGH_0904					

*Table continues...*

	Gas			Steam	Electric	
055 Series (24 Kg)	BA055L	HT055D	PT055L	Not Applicable	BH055E	MT055E
	BA055N	HT055L	PT055N		BH055F	MT055F
	BH055L	HT055N	PU055L		BT055E	NH055E
	BH055N	HT055R	PU055N		BT055F	NT055E
	BH055R	HU055L	SA055L		BU055E	NU055E
	BK055N	HU055N	SA055N		BU055F	PH055E
	BK055R	HU055R	SH055L		CT055E	PT055E
	BT055D	IT055L	SH055N		CT055F	PU055E
	BT055L	IT055N	SH055R		CU055E	SH055E
	BT055N	IT055R	SK055N		CU055F	SH055F
	BT055R	LA055L	SK055R		HH055E	ST055E
	BU055L	LA055N	ST055D		HH055F	ST055F
	BU055N	LK055N	ST055L		HT055E	SU055E
	BU055R	LT055L	ST055N		HT055F	SU055F
	CA055L	LT055N	ST055R		HU055E	UH055E
	CA055N	LU055L	SU055L		HU055F	UH055F
	CK055N	LU055N	SU055N		IT055E	UT055E
	CK055R	MT055L	SU055R		IT055F	UT055F
	CT055L	MT055N	UA055L		LT055E	UU055E
	CT055N	MT055R	UA055N		LU055E	UU055F
	CT055R	NH055L	UH055L			
	CU055L	NH055N	UH055N			
	CU055N	NT055L	UH055R			
	CU055R	NT055N	UK055N			
	HA055L	NU055L	UK055R			
	HA055N	NU055N	UT055L			
	HH055L	PA055L	UT055N			
	HH055N	PA055N	UT055R			
	HH055R	PH055L	UU055L			
	HK055N	PH055N	UU055N			
	HK055R	PK055N	UU055R			

Explanation of digit in 6th position of model number:

D = Liquid Petroleum (L.P.) Gas, Japan

E = Electric

*Table continues...*

F = Reduced Electric (Eco Line)
L = L.P. Gas
N = Natural Gas
R = Reduced Gas, Natural Gas (Eco Line)
S = Steam

Includes models with the following control suffixes:

3B – reversing DX4 vended	KK – reversing prep for central pay	RU – reversing UniLinc OPL
3K – reversing DX4 prep for central pay	KL – prep for central pay	SD – single drop
3L – DX4 prep for central pay	KW – reversing prep for coin	SX – single drop, prep for coin
3O – DX4 OPL	KX – prep for coin	UO – UniLinc OPL
3V – DX4 vended	KY – prep for card	WB – reversing network ready coin
3W – reversing DX4 prep for coin	KZ – reversing prep for card	WC – network ready coin
3X – DX4 prep for coin	LB – reversing network adaptable coin	WK – reversing network ready, prep for central pay
BB – reversing basic electronic, coin	LC – network adaptable coin	WL – network ready, prep for central pay
BC – basic electronic, coin	LK – reversing network adaptable, prep for central pay	WW – reversing network ready, prep for coin
BG – basic electronic, OPL mode	LL – network adaptable, prep for central pay	WX – network ready, prep for coin
BK – reversing basic electronic, prep for central pay	LW – reversing network adaptable, prep for coin	WY – network ready, prep for card
BL – basic electronic, prep for central pay	LX – network adaptable, prep for coin	WZ – reversing network ready, prep for card
BW – reversing basic electronic, prep for coin	LY – network adaptable, prep for card	ZB – reversing network ready, single coin
BX – basic electronic, prep for coin	LZ – reversing network adaptable, prep for card	ZC – network ready, single coin
BY – basic electronic, prep for card	NC – NetMaster coin	ZK – reversing network ready, prep for central pay
BZ – reversing basic electronic, prep for card	NR – NetMaster card	ZL – network ready, prep for central pay
DO – DMP OPL	NX – NetMaster, prep for coin	ZR – network card
DV – DMP vended	NY – NetMaster, prep for card	ZW – reversing network ready, prep for coin
DX – DMP prep for coin	OM – OPL micro	ZX – network ready, prep for coin
EO – LED OPL	QT – dual digital timer	ZY – network ready, prep for card
KB – reversing single coin	R3 – reversing DX4 OPL	ZZ – reversing network ready, prep for card
KC – single coin	RE – reversing LED OPL	
	RQ – reversing dual digital timer	

## Contact Information

If service is required, contact the nearest Factory Authorized Service Center.

If you are unable to locate an authorized service center or are unsatisfied with the service performed on your unit, contact:

**Alliance Laundry Systems**  
**Shepard Street**  
**P.O. Box 990**  
**Ripon, WI 54971-0990**  
**U.S.A.**  
**[www.alliancelandry.com](http://www.alliancelandry.com)**



**Phone: +1 (920) 748-3121**

When calling or writing about your unit, PLEASE GIVE THE MODEL AND SERIAL NUMBERS. The model and serial numbers are located on the serial plate. The serial plate will be in the location shown in *Figure 1*.

Date Purchased	
Model Number	
Serial Number	

Please include a copy of your bill of sale and any service receipts you have.

	<h2 style="margin: 0;">WARNING</h2>
<p><b>To reduce the risk of serious injury or death, DO NOT repair or replace any part of the unit or attempt any servicing unless specifically recommended in the user-maintenance instructions or in published user-repair instructions that you understand and have the skills to carry out.</b></p>	
<p>W329</p>	

If replacement parts are required, contact the source from where you purchased your unit or call +1 (920) 748-3950 for the name and address of the nearest authorized parts distributor.

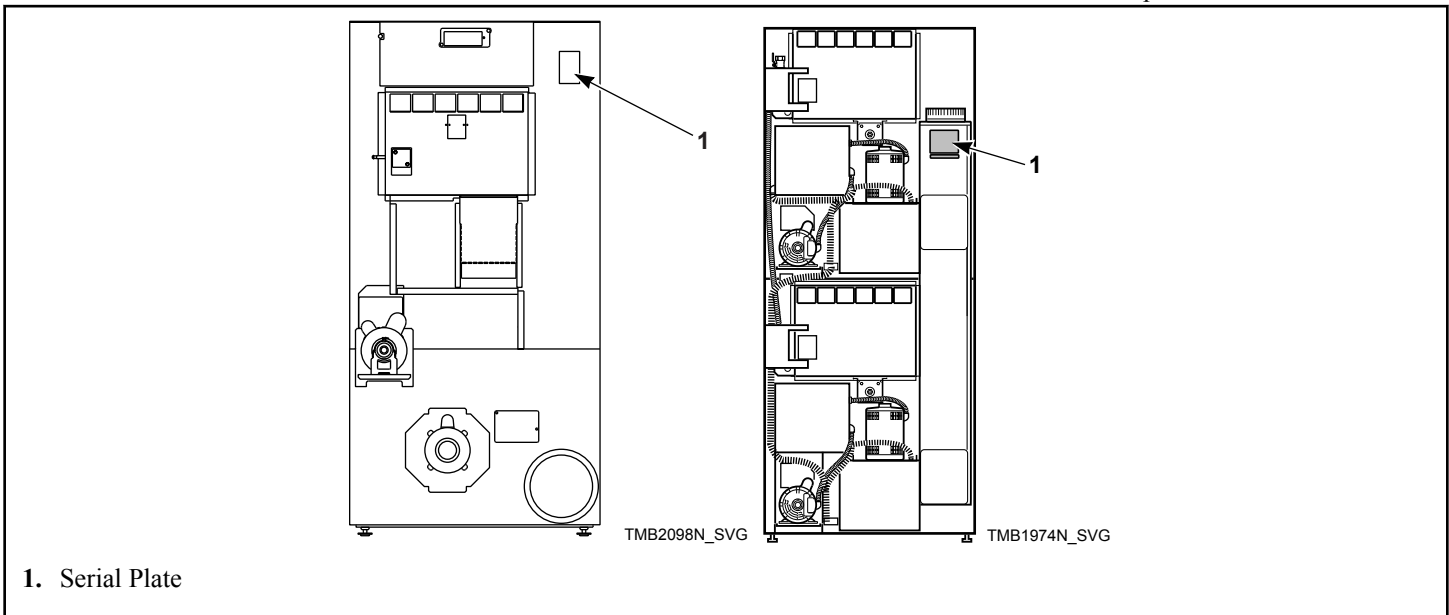

Figure 1

## Manufacturing Date

### Manufacturing Date

The manufacturing date for your unit can be found on the serial number. The first two digits indicate the year. The third and fourth digits indicate the month. For example, a unit with serial number 1505000001 was manufactured in May 2015.





# Safety Information

## Explanation of Safety Messages

Precautionary statements (“DANGER,” “WARNING,” and “CAUTION”), followed by specific instructions, are found in this manual and on machine decals. These precautions are intended for the personal safety of the operator, user, servicer, and those maintaining the machine.

	<b>DANGER</b>
Indicates an imminently hazardous situation that, if not avoided, will cause severe personal injury or death.	

	<b>WARNING</b>
Indicates a hazardous situation that, if not avoided, could cause severe personal injury or death.	

	<b>CAUTION</b>
Indicates a hazardous situation that, if not avoided, may cause minor or moderate personal injury or property damage.	

Additional precautionary statements (“IMPORTANT” and “NOTE”) are followed by specific instructions.

**IMPORTANT:** The word “IMPORTANT” is used to inform the reader of specific procedures where minor machine damage will occur if the procedure is not followed.

**NOTE:** The word “NOTE” is used to communicate installation, operation, maintenance or servicing information that is important but not hazard related.

## Important Safety Instructions

	<b>WARNING</b>
To reduce the risk of fire, electric shock, serious injury or death to persons when using your tumble dryer, follow these basic precautions.	
W776R1	

### Save These Instructions

- Read all instructions before using the tumble dryer.

- Install the tumble dryer according to the INSTALLATION instructions. Refer to the EARTHING (grounding) instructions for the proper earthing (grounding) of the tumble dryer. All connections for electrical power, earthing (grounding) and gas supply must comply with local codes and be made by licensed personnel when required. It is recommended that the machine be installed by qualified technicians.
- Do not install or store the tumble dryer where it will be exposed to water and/or weather. The tumble dryer cannot be used in a closed room where the air supply is insufficient. If necessary, ventilation grids must be installed in the doors or the windows.
- This tumble dryer must not be activated without lint screen filter.
- When you perceive a gas odor, immediately shut off the gas supply and ventilate the room. Do not power on electrical appliances and do not pull electrical switches. Do not use matches or lighters. Do not use a phone in the building. Warn the installer, and if so desired, the gas company, as soon as possible.
- To avoid fire and explosion, keep surrounding areas free of flammable and combustible products. Regularly clean the cylinder and exhaust tube should be cleaned periodically by competent maintenance personnel. Daily remove debris from lint screen filter and inside of filter compartment.
- Do not use or store flammable materials near this appliance.
- Do not place into tumble dryer articles that have been previously cleaned in, washed in, soaked in or spotted with gasoline or machine oils, vegetable or cooking oils, cleaning waxes or chemicals, dry-cleaning solvents, thinner or other flammable or explosive substances as they give off vapors that could ignite, explode or cause fabric to catch on fire by itself.
- Do not spray aerosols in the vicinity of this appliance while it is in operation.
- Items such as foam rubber (latex foam), shower caps, waterproof textiles, rubber backed articles and clothes or pillows filled with foam rubber pads should not be dried in the tumble dryer. Do not use the appliance to dry materials with a low melting temperature (PVC, rubber, etc.).
- Do not tumble fiberglass curtains and draperies unless the label says it can be done. If they are dried, wipe out the cylinder with a damp cloth to remove particles of fiberglass.
- Do not allow children to play on or in the dryer. Close supervision of children is necessary when the dryer is used near children. This appliance is not intended for use by persons (including children) with reduced physical, sensory or mental capabilities, or lack of experience and knowledge, unless they have been given supervision or instruction concerning the use of the appliance by a person responsible for their safety. This is a safety rule for all appliances.
- Cleaning and user maintenance shall not be made by children without supervision.

- Children less than three years should be kept away unless continuously supervised.
- Do not reach into the tumble dryer if the cylinder is revolving.
- Use tumble dryer only for its intended purpose, drying fabrics. Always follow the fabric care instructions supplied by the textile manufacturer and only use the dryer to dry textiles that have been washed in water. Only insert spin-dried linen in the dryer to avoid damage to dryer.
- Always read and follow manufacturer's instructions on packages of laundry and cleaning aids. Follow all warnings or precautions. To reduce the risk of poisoning or chemical burns, keep them out of the reach of children at all times (preferably in a locked cabinet).
- Do not use fabric softeners or products to eliminate static unless recommended by the manufacturer of the fabric softener or product.
- Remove laundry immediately after tumble dryer stops.
- DO NOT operate the tumble dryer if it is smoking, grinding or has missing or broken parts or removed guards or panels. DO NOT tamper with the controls or bypass any safety devices.
- Tumble dryer will not operate with the loading door open. DO NOT bypass the door safety switch to permit the tumble dryer to operate with the door open. The tumble dryer will stop rotating when the door is opened. Do not use the tumble dryer if it does not stop rotating when the door is opened or starts tumbling without pressing the START mechanism. Remove the tumble dryer from use and call for service.
- Tumble dryer will not operate with lint panel open. DO NOT bypass lint panel door safety switch to permit the tumble dryer to operate with the lint panel door open.
- Do not alter this tumble dryer from factory construction except as otherwise described in the technical instructions.
- Always clean the lint filter daily. Keep area around the exhaust opening and adjacent surrounding area free from the accumulation of lint, dust and dirt. The interior of the tumble dryer and the exhaust duct should be cleaned periodically by qualified service personnel.
- Solvent vapors from dry-cleaning machines create acids when drawn through the heater of the drying unit. These acids are corrosive to the tumble dryer as well as the laundry load being dried. Be sure make-up air is free of solvent vapors.
- At the end of each working day, close off all main supplies of gas, steam and electricity.

**IMPORTANT: For fire suppression equipped tumble dryers, electricity and water should NOT be turned off.**

- Do not repair or replace any part of the tumble dryer, or attempt any servicing unless specifically recommended in the user-maintenance instructions or in published user-repair instructions that the user understands and has the skills to carry out. ALWAYS disconnect and lockout the electrical power to the tumble dryer before servicing. Disconnect power by shutting off appropriate breaker or fuse.

- Activation of the emergency stop switch stops all tumble dryer control circuit functions, but DOES NOT remove all electrical power from tumble dryer.
- Exhaust ductwork should be examined and cleaned annually after installation.
- Before the tumble dryer is removed from service or discarded, remove the door to the drying compartment and the door to the lint compartment.
- Failure to install, maintain, and/or operate this tumble dryer according to the manufacturer's instructions may result in conditions which can produce bodily injury and/or property damage.

**NOTE: The WARNINGS and IMPORTANT SAFETY INSTRUCTIONS appearing in this manual are not meant to cover all possible conditions and situations that may occur. Observe and be aware of other labels and precautions that are located on the machine. They are intended to provide instruction for safe use of the machine. Common sense, caution and care must be exercised when installing, maintaining, or operating the tumble dryer.**

Always contact your dealer, distributor, service agent or the manufacturer about any problems or conditions you do not understand.

**NOTE: All appliances are produced according the EMC-directive (Electro-Magnetic-Compatibility). They can be used in restricted surroundings only (comply minimally with class A requirements). For safety reasons there must be kept the necessary precaution distances with sensitive electrical or electronic device(s). These machines are not intended for domestic use by private consumers in the home environment.**

# Specifications and Dimensions

## Specifications and Dimensions

Refer to machine serial plate for additional specifications.

Specifications	025 Series	030 Series	035 Series	055 Series
Heat dissipation of surface area exposed to conditioned air: Btu/ft <sup>2</sup> [Joules/m <sup>2</sup> ]	60 [681,392]	60 [681,392]	60 [681,392]	60 [681,392]
Noise level measured during operation at operator position of 3.3 feet [1 meter] in front of machine and 5.2 feet [1.6 meters] from floor	60 dBA	61 dBA	63 dBA	63 dBA
Net Weight (approximate): Pounds [kg]	300 [137]	330 [150]	360 [163]	435 [197]
Standard Packaging Weight: Pounds [kg]	332 [151]	364 [165]	394 [179]	476 [216]
Standard Packaging Shipping Dimensions: Inch [mm]	30 x 43 x 69 [762 x 1,092 x 1,753]	30 x 49 x 69 [762 x 1,245 x 1,753]	33 x 49 x 69 [838 x 1,245 x 1,753]	35.5 x 59 x 72 [902 x 1,499 x 1,829]
Slat Crate Packaging Weight: Pounds [kg]	406 [184]	446 [202]	480 [218]	506 [230]
Slat Crate Shipping Dimensions: Inch [mm]	34.5 x 46 x 87.75 [876 x 1,168 x 1,229]	34.5 x 52 x 87.75 [876 x 1,321 x 2,229]	37.5 x 52 x 87.75 [953 x 1,321 x 2,229]	40 x 60 x 87.25 [1,016 x 1,524 x 2,216]
Cylinder Size: Inch [mm]	26.5 x 24 [673 x 610]	26.5 x 30 [673 x 762]	30 x 30 [762 x 762]	33 x 35 [838 x 889]
Cylinder Capacity (dry weight): Pounds [kg]	25 [11]	30 [13]	35 [16]	55 [24]
Drive Motor: Horsepower [kW]	1/4 [0.1865]	1/4 [0.1865]	1/4 [0.1865]	Nonreversing 1/2 [0.373] Reversing 1/4 [0.1865]
Fan Motor: Horsepower [kW]	1/4 [0.1865]	1/4 [0.1865]	1/4 [0.1865]	1/2 [0.373]

*Table continues...*

Specifications		025 Series	030 Series	035 Series	055 Series
Maximum Airflow: C.F.M. [l/ sec]	50 Hertz	Standard Line 430 [203] Eco Line 250 [118]	430 [203]	Standard Line 550 [260] Eco Line 450 [212]	600 [283]
	60 Hertz	Standard Line 500 [236] Eco Line 300 [142]	500 [236]	Standard Line 650 [307] Eco Line 550 [260]	700 [330]
Maximum Static Back Pressure: Inch W.C. [mbar, kPa]	50 Hertz	Standard Line 0.6 [1.5, 0.15] Eco Line 1.0 [2.5]	0.6 [1.5, 0.15]	Standard Line 0.5 [1.3, 0.13] Eco Line 0.7 [1.7]	0.5 [1.3, 0.13]
	60 Hertz	Standard Line 0.8 [2.0, 0.2] Eco Line 1.4 [3.5, 0.35]	0.8 [2.0, 0.2]	Standard Line 0.6 [1.5, 0.15] Eco Line 0.9 [2.2, 0.22]	0.6 [1.5, 0.15]
Minimum Static Back Pressure: Inch W.C. [mbar, kPa]		0.0 [0.0, 0.0]	0.0 [0.0, 0.0]	0.0 [0.0, 0.0]	0.0 [0.0, 0.0]
<b>Gas Models</b>					
Gas Connection		1/2 in. NPT	1/2 in. NPT	1/2 in. NPT	1/2 in. NPT
Gas Burner Rating: Btu/hr. [kW, Mj/hr.]	50 Hertz	Standard Line 64,000 [18.7, 67.5] Eco Line 45,000 [13.2, 47.5]	Standard Line 73,000 [21.4, 77] Eco Line 52,500 [15.4, 55.4]	Standard Line 90,000 [26.4, 95] Eco Line 55,000 [16.1, 58.0]	Standard Line 102,000 [29.9, 107.6] Eco Line 90,000 [26.4, 95.0]
	60 Hertz	Standard Line 64,000 [18.7, 67.5] Eco Line 52,500 [15.4, 55.4]	Standard Line 73,000 [21.4, 77] Eco Line 55,000 [16.1, 58.0]	Standard Line 90,000 [26.4, 95] Eco Line 64,000 [18.7, 67.5]	Standard Line 112,000 [32.8, 118.2] Eco Line 105,000 [30.8, 110.8]
<b>Electric Models</b>					

*Table continues...*

Specifications and Dimensions

Specifications		025 Series	030 Series	035 Series	055 Series
Heating Element Rating:	400/50/3	10 kW	Standard Line - 21 kW	Standard Line - 24 kW	Standard Line - 27 kW
	Standard	Standard Line - 12 kW Eco Line - 9 kW	Eco Line - 12 kW	Eco Line - 12 kW	Eco Line - 18 kW
<b>Steam Models</b>					
Steam Connection		3/4 in. NPT	3/4 in. NPT	3/4 in. NPT	N/A
Steam Coil Rating at 100 psig: Btu/hr. [kg/hr.]  (recommended operating pressure 80-100 psig)		134,700 [63.1]	134,700 [63.1]	166,000 [77.8]	N/A
N/A = Not Applicable					

**NOTE: All machines are shipped with extra nipple to convert to metric thread (from Standard).**

Specifications	T30 Series	T45 Series
Noise level measured during operation at operator position of 3.3 feet [1 meter] in front of machine and 5.2 feet [1.6 meters] from floor	66 dBA	67 dBA
Net Weight (approximate): Pounds [kg]	544 [247]	673 [305]
Standard Packaging Weight: Pounds [kg]	582 [264]	718 [326]
Standard Packaging Shipping Dimensions: Inch [mm]	32.5 x 47 x 81 [826 x 1,194 x 2,057]	35.5 x 54 x 85 [902 x 1,372 x 2,159]
Slat Crate Packaging Weight: Pounds [kg]	661 [300]	748 [339]
Slat Crate Shipping Dimensions: Inch [mm]	37 x 50 x 87.75 [940 x 1,270 x 2,229]	40 x 57 x 87.25 [1,016 x 1,448 x 2,216]
Cylinder Size: Inch [mm]	30 x 26 [762 x 660]	33 x 30 [838 x 762]
Cylinder Capacity (dry weight): Pounds [Kilograms]	2 x 30 [2 x 13]	2 x 45 [2 x 20]

*Table continues...*

Specifications		T30 Series	T45 Series
Drive Motor (per pocket): Horsepower [kW]		1/4 [0.1865]	1/2 [0.373]
Fan Motor (per pocket): Horsepower [kW]		1/4 [0.1865]	1/2 [0.373]
Maximum Airflow (per pocket): C.F.M. [l/sec]	50 Hertz	Standard Line 340 [160] Eco Line 225 [106]	500 [236]
	60 Hertz	Standard Line 400 [189] Eco Line 330 [156]	600 [283]
Maximum Static Back Pressure (total machine): Inch W.C. [mbar, kPa]	50 Hertz	Standard Line 0.8 [2.0, 0.2] Eco Line 1.2 [3.0]	0.8 [2.0, 0.2]
	60 Hertz	Standard Line 0.9 [2.3, 0.23] Eco Line 1.7 [4.2]	0.9 [2.3, 0.23]
Minimum Static Back Pressure (total machine): Inch W.C. [mbar, kPa]		0.0 [0.0, 0.0]	0.0 [0.0, 0.0]
<b>Gas Models</b>			
Gas Connection		1/2 in. NPT	1/2 in. NPT
Gas Burner Rating (per pocket): Btu/hr. [kW, Mj/hr.]	50 Hertz	Standard Line 73,000 [21.4, 77] Eco Line 52,500 [15.4, 55.4]	Standard Line 87,000 [25.5, 91.8] Eco Line 74,000 [21.7, 78.1]
	60 Hertz	Standard Line 73,000 [21.4, 77] Eco Line 55,000 [16.1, 58.0]	Standard Line 95,000 [27.8, 100.2] Eco Line 80,000 [23.5, 84.4]

Table continues...

Specifications	T30 Series	T45 Series
<b>Electric Models</b>		
Heating Element Rating (per pocket):	Standard Line - 21 kW Eco Line - 12 kW	N/A
<b>Steam Models</b>		
Steam Connection	3/4 in. NPT	N/A
Steam Coil Rating at 100 psig (per pocket): Btu/hr. [kg/hr.] (recommended operating pressure 80-100 psig)	111,000 [52]	N/A

N/A = Not Applicable

**NOTE: All machines are shipped with extra nipple to convert to metric thread (from Standard).**

### Cabinet Dimensions – 025, 030, 035 and 055 Series

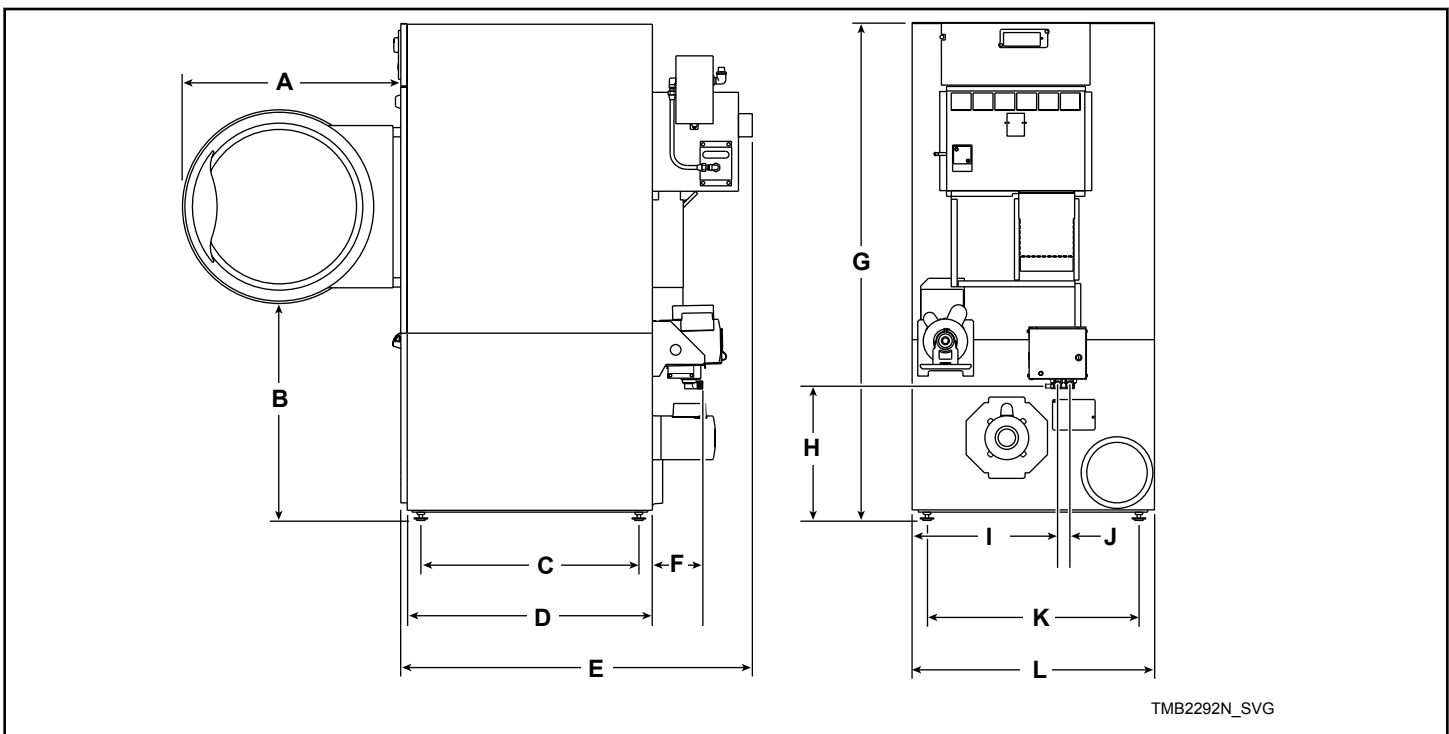

Models	A	B	C	D	E	F*
025 Series	26.25 in. [667 mm]	27.5 in. [669 mm]	22.35 in. [568 mm]	25.75 in. [654 mm]	40.875 in. [1,038 mm]	6.53 in. [166 mm]
030 Series	26.25 in. [667 mm]	27.5 in. [669 mm]	28.35 in. [720 mm]	31.75 in. [806 mm]	46.875 in. [1,191 mm]	6.53 in. [166 mm]

*Table continues...*



Models	A	B	C	D	E	F*
035 Series	28 in. [711 mm]	27.5 in. [669 mm]	28.35 in. [720 mm]	31.75 in. [806 mm]	46.875 in. [1,191 mm]	6.53 in. [166 mm]
055 Series	31.88 in. [810 mm]	26.87 in. [682.5 mm]	33.75 in. [857.25 mm]	38.25 in. [971.5 mm]	53.62 in. [1,365 mm]	6.53 in. [166 mm]

Models	G	H*	I*	J*	K	L
025 Series	63.875 in. [1,622 mm]	16.48 in. [419 mm]	15.41 in. [391 mm]	1.59 in. [40 mm]	24.64 in. [626 mm]	28 in. [711 mm]
030 Series	63.875 in. [1,622 mm]	16.48 in. [419 mm]	15.41 in. [391 mm]	1.59 in. [40 mm]	24.64 in. [626 mm]	28 in. [711 mm]
035 Series	63.875 in. [1,622 mm]	16.48 in. [419 mm]	19.59 in. [497.5 mm]	1.59 in. [40 mm]	27.38 in. [695 mm]	31.5 in. [800 mm]
055 Series	66.72 in. [1,694.7 mm]	17.75 in. [451 mm]	18.65 in. [474 mm]	1.59 in. [40 mm]	30.5 in. [774.7 mm]	34.5 in. [876 mm]

\* Fire suppression system optional - may not be on machine.

**NOTE: Facia panels available to increase height of models to 72.25 inches [1,835 mm] and 76.25 inches [1,938 mm].**

## Cabinet Dimensions – T30 and T45 Series

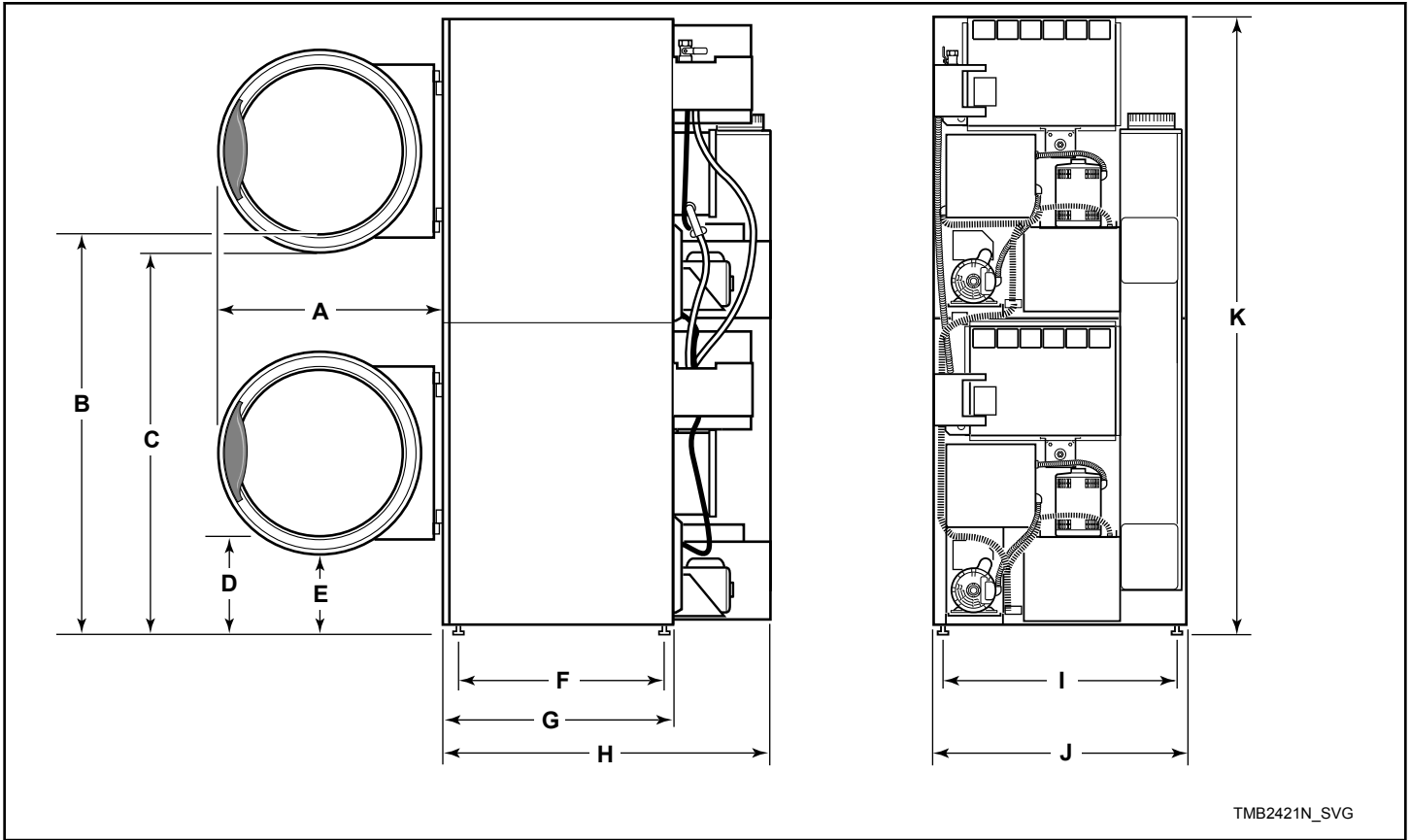

TMB2421N\_SVG

Models	A	B	C	D	E
T30 Series	28 in. [711 mm]	49 in. [1,245 mm]	48.25 in. [1,226 mm]	11.4 in. [290 mm]	10.7 in. [272 mm]
T45 Series	31.88 in. [810 mm]	50.4 in. [1,280 mm]	49.3 in. [1,252 mm]	10.3 in. [262 mm]	9.3 in. [236 mm]

Models	F	G	H	I	J	K
T30 Series	25.02 in. [636 mm]	28.67 in. [728 mm]	42.76 in. [1,086 mm]	27.38 in. [695 mm]	31.5 in. [800 mm]	76.25 in. [1,937 mm]
T45 Series	29.37 in. [746 mm]	32.7 in. [831 mm]	48.62 in. [1,235 mm]	30.50 in. [775 mm]	34.5 in. [876 mm]	81.25 in. [2,064 mm]

**NOTE: To meet ADA compliance, install a 4 inch [102 mm] riser on T30 models only.**

## Exhaust Outlet Locations – 025, 030, 035 and 055 Series

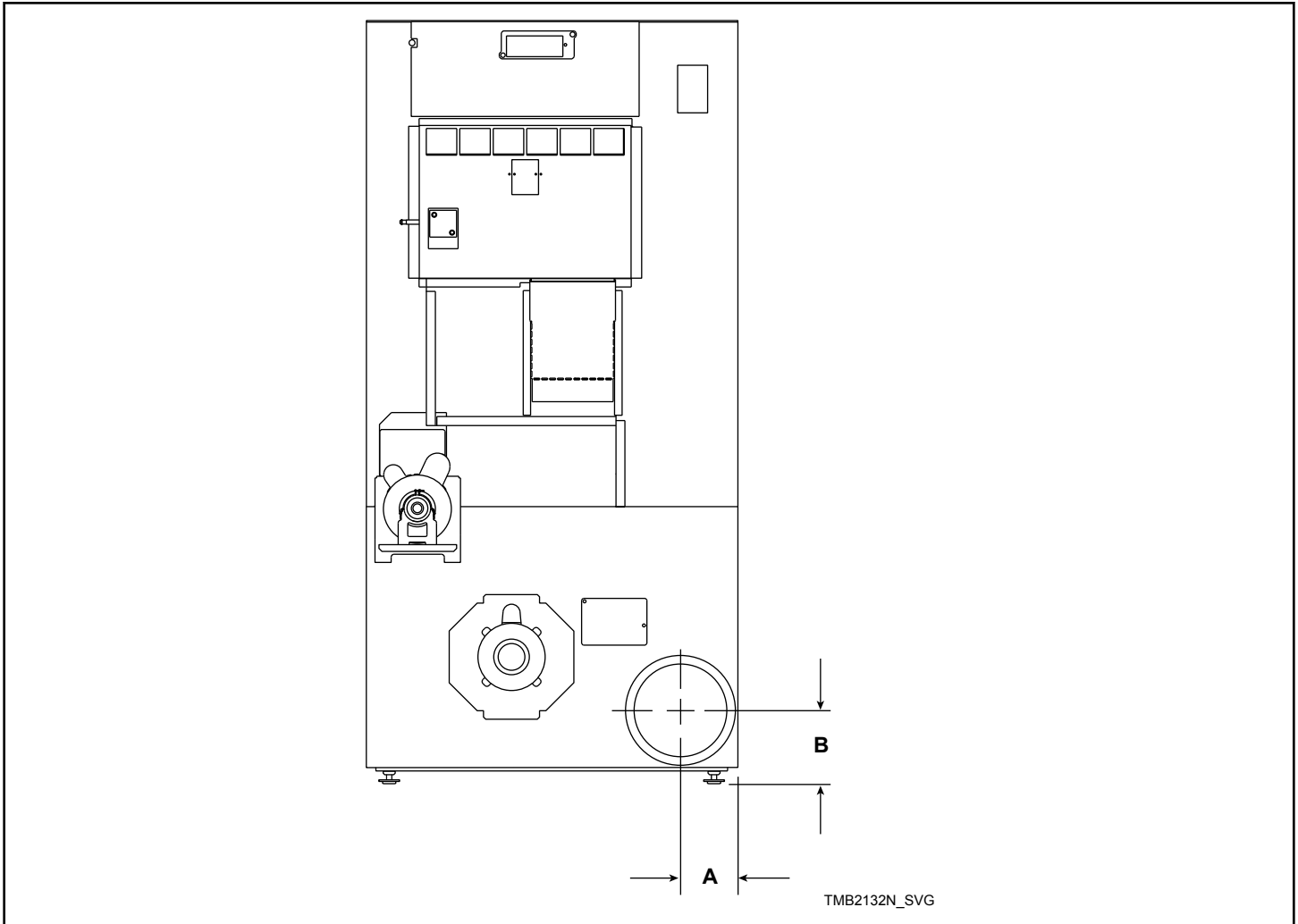

Models	Rear Exhaust		
	Diameter	A	B
025 Series	Standard Line 6 in. [152 mm] Eco Line 4 in. [102 mm]	3.875 in. [99 mm]	4.625 in. [117 mm]
030 Series	6 in. [152 mm]	3.875 in. [99 mm]	4.625 in. [117 mm]

*Table continues...*

Models	Rear Exhaust		
	Diameter	A	B
035 Series	Standard Line 8 in. [203 mm]	4.875 in. [124 mm]	5.625 in. [143 mm]
	Eco Line 6 in. [152 mm]		
055 Series	8 in. [203 mm]	4.808 in. [122 mm]	6.156 in. [156.3 mm]

### Exhaust Outlet Locations – T30 and T45 Series

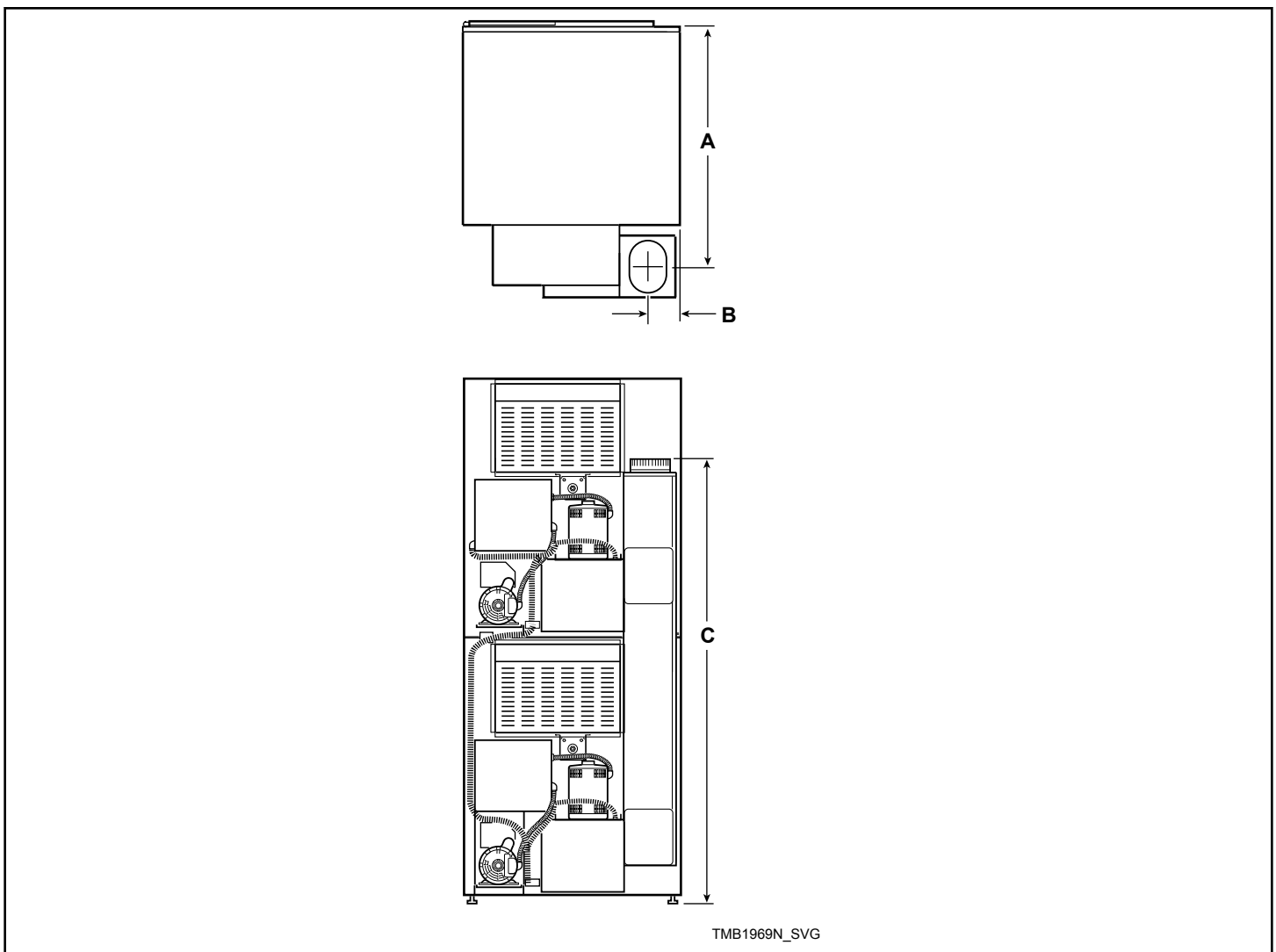

Models	Rear Exhaust			
	Diameter	A	B	C
T30 Series	Standard Line Elliptical Fits 8 in. [203 mm] Eco Line Round Fits 6 in. [152 mm]	36.54 in. [928 mm]	4.25 in. [108 mm]	62.42 in. [1,585 mm]
T45 Series	Elliptical Fits 10 in. [254 mm]	40.88 in. [1,038 mm]	4.75 in. [121 mm]	66.00 in. [1,676 mm]

### Gas Connection Locations – 025, 030, 035 and 055 Series

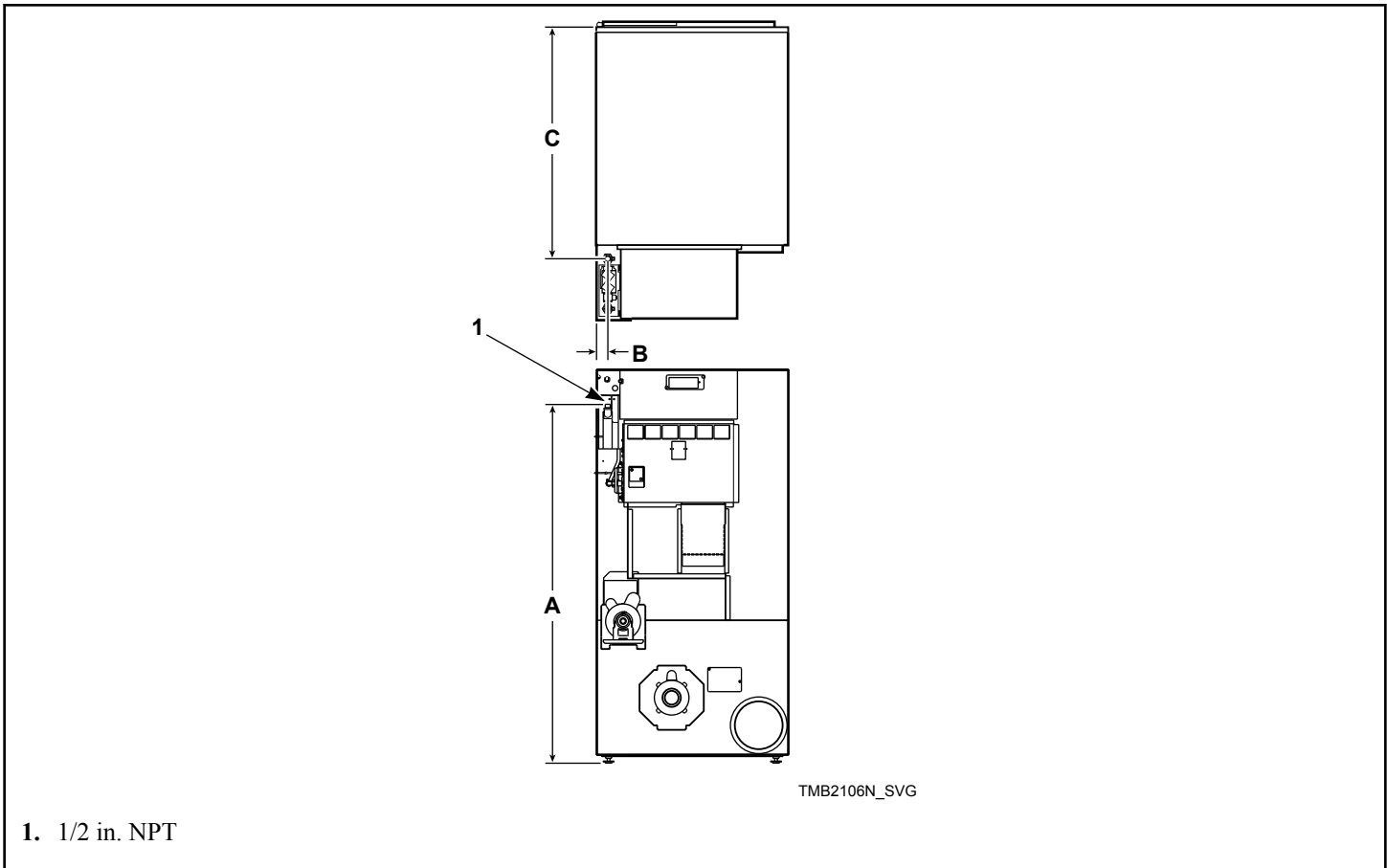

<b>Models</b>	<b>Gas Connection – CE and Australian Units</b>		
	<b>A</b>	<b>B</b>	<b>C</b>
25 Series	59 in. [1,500 mm]	1.5 in. [38.1 mm]	29 in. [737 mm]
30 Series	59 in. [1,500 mm]	1.5 in. [38.1 mm]	35 in. [889 mm]
35 Series	59 in. [1,500 mm]	2.5 in. [64 mm]	35 in. [889 mm]
55 Series	59 in. [1,500 mm]	2.5 in. [64 mm]	35 in. [889 mm]

<b>Models</b>	<b>Gas Connection – Non-CE and Non-Australian Units</b>		
	<b>A</b>	<b>B</b>	<b>C</b>
25 Series	57 in. [1,450 mm]	2.5 in. [64 mm]	35.5 in. [927 mm]
30 Series	57 in. [1,450 mm]	2.5 in. [64 mm]	43 in. [1,092 mm]
35 Series	57 in. [1,450 mm]	4 in. [101.6 mm]	43 in. [1,092 mm]
55 Series	55.285 in. [1,404 mm]	1.621 in. [41.17 mm]	46.75 in. [1,187.45 mm]

## Gas Connection Locations – T30 and T45 Series

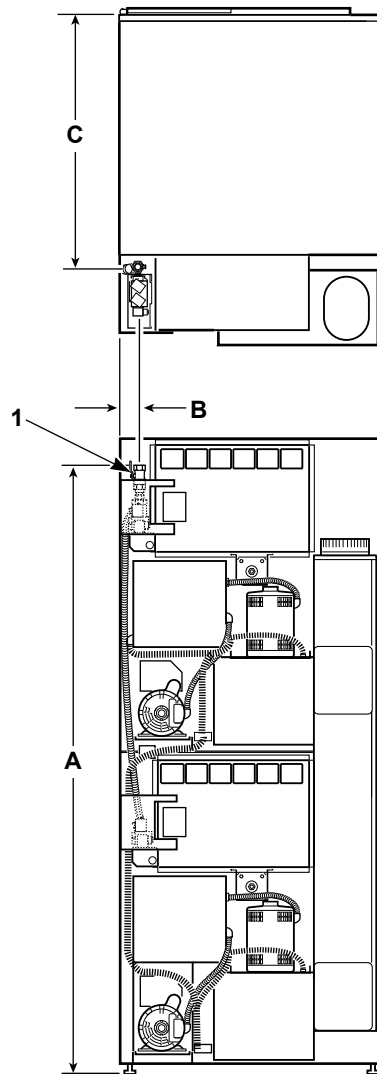

TMB1970N\_SVG

1. 1/2 in. NPT

Models		Gas Connection		
		A	B	C
T30 Series	Non-CE and Non-Australian	75.20 in. [1,910 mm]	1.74 in. [44 mm]	36.84 in. [936 mm]
	CE and Australian	75.28 in. [1,912 mm]	2.5 in. [64 mm]	30.60 in. [777 mm]
T45 Series		78.75 in. [2,000 mm]	4.12 in. [105 mm]	42.88 in. [1,089 mm]

## Electrical Connection Locations – 025, 030, 035 and 055 Series

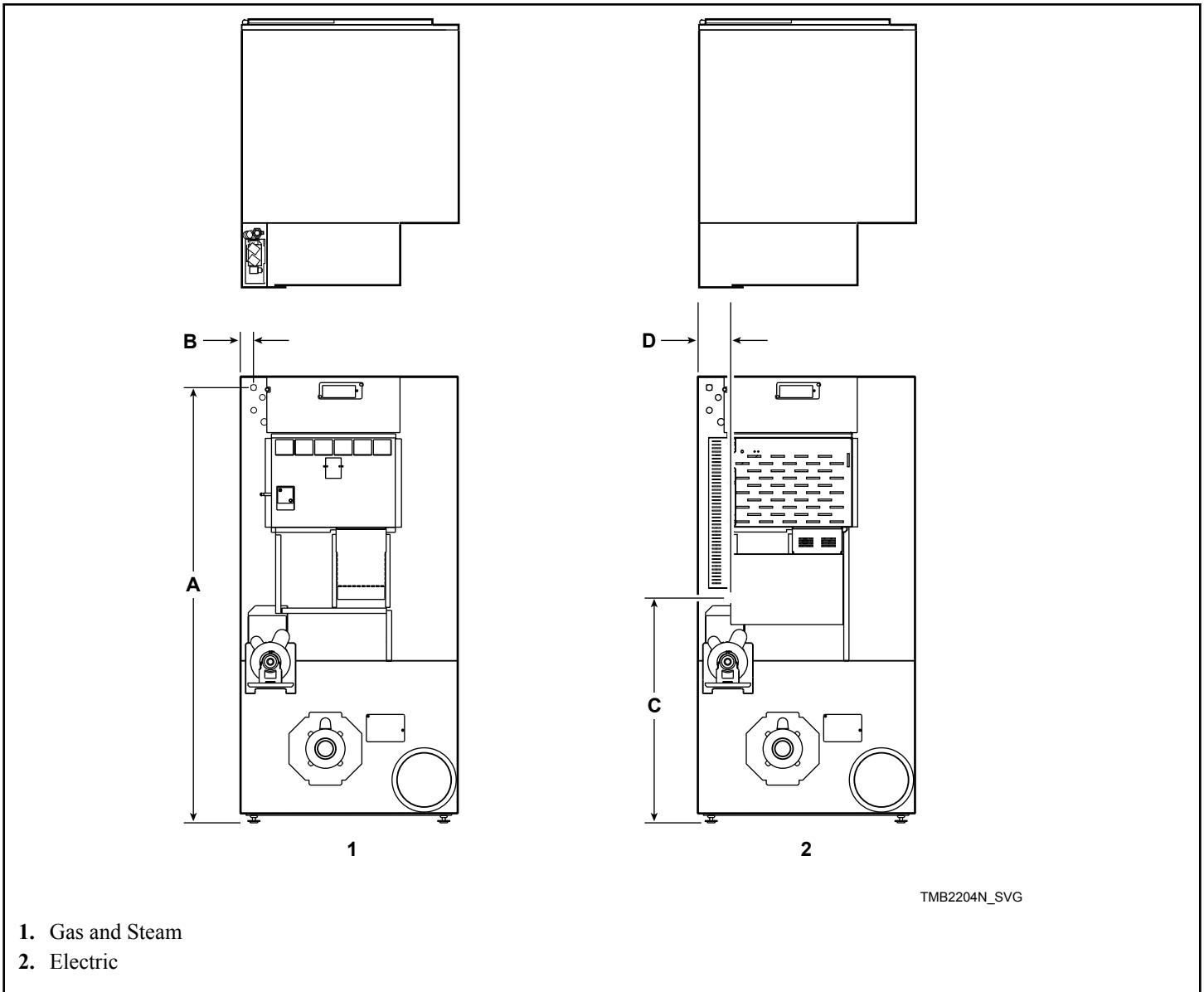

Models	Electrical Service			
	Gas and Steam Models		Electric Models	
	A	B	C	D
025/030 Series	62.25 in. [1,581 mm]	2 in. [51 mm]	28 in. [711 mm]	3.25 in. [83 mm]
035 Series	62.25 in. [1,581 mm]	3 in. [76 mm]	28 in. [711 mm]	4.25 in. [108 mm]
055 Series	65.187 in. [1,655.75 mm]	1.765 in. [44.83 mm]	32.526 in. [826.16 mm]	6.547 in. [166.3 mm]



## Electrical Connection Locations – T30 and T45 Series

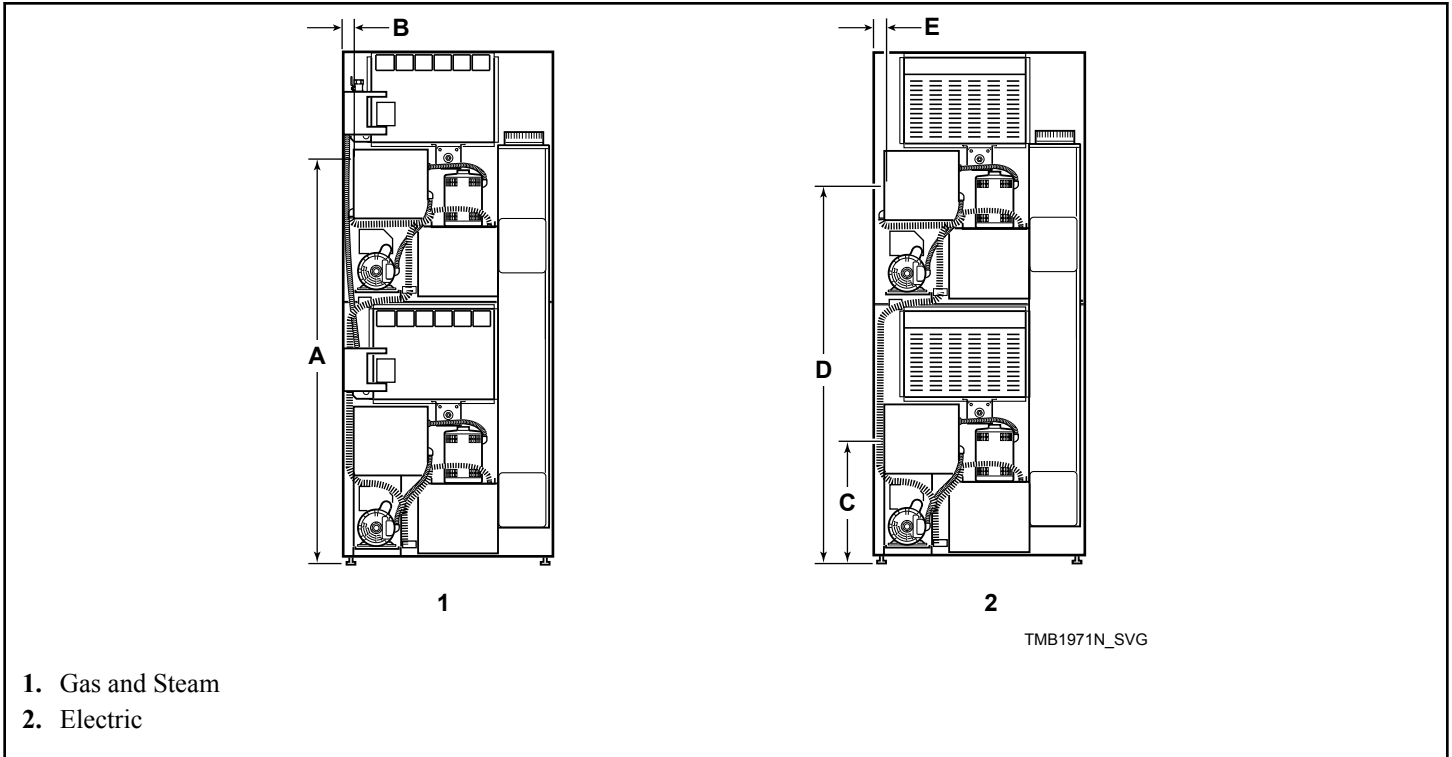

Models	Electric Service				
	Gas and Steam Models		Electric Models		
	A	B	C	D	E
T30 Series	59 in. [1,498 mm]	1.75 in. [44 mm]	35.63 in. [905 mm]	73.21 in. [1,859 mm]	2.28 in. [58 mm]
T45 Series	62.5 in. [1,588 mm]	1.75 in. [44 mm]	N/A	N/A	N/A

N/A = Not Applicable

## Steam Connection Locations – 025, 030 and 035 Series

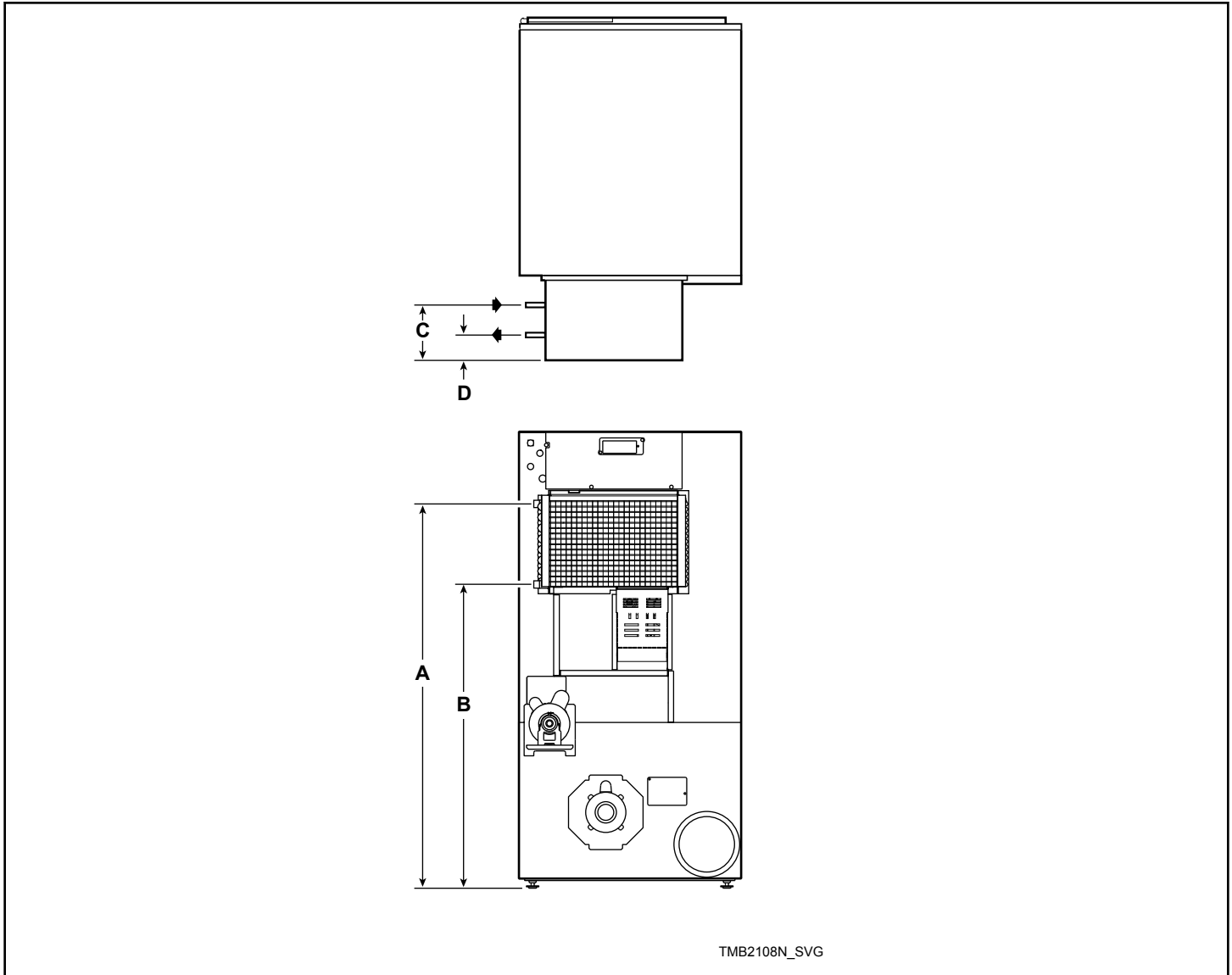

Models	Inlet		Outlet	
	A	C	B	D
025/030/035 Series	53.75 in. [1,365 mm]	6.29 in. [160 mm]	42.5 in. [1,080 mm]	2.39 in. [61 mm]

**NOTE: All connections use 3/4 in. NPT pipe.**

## Steam Connection Locations – T30 Series

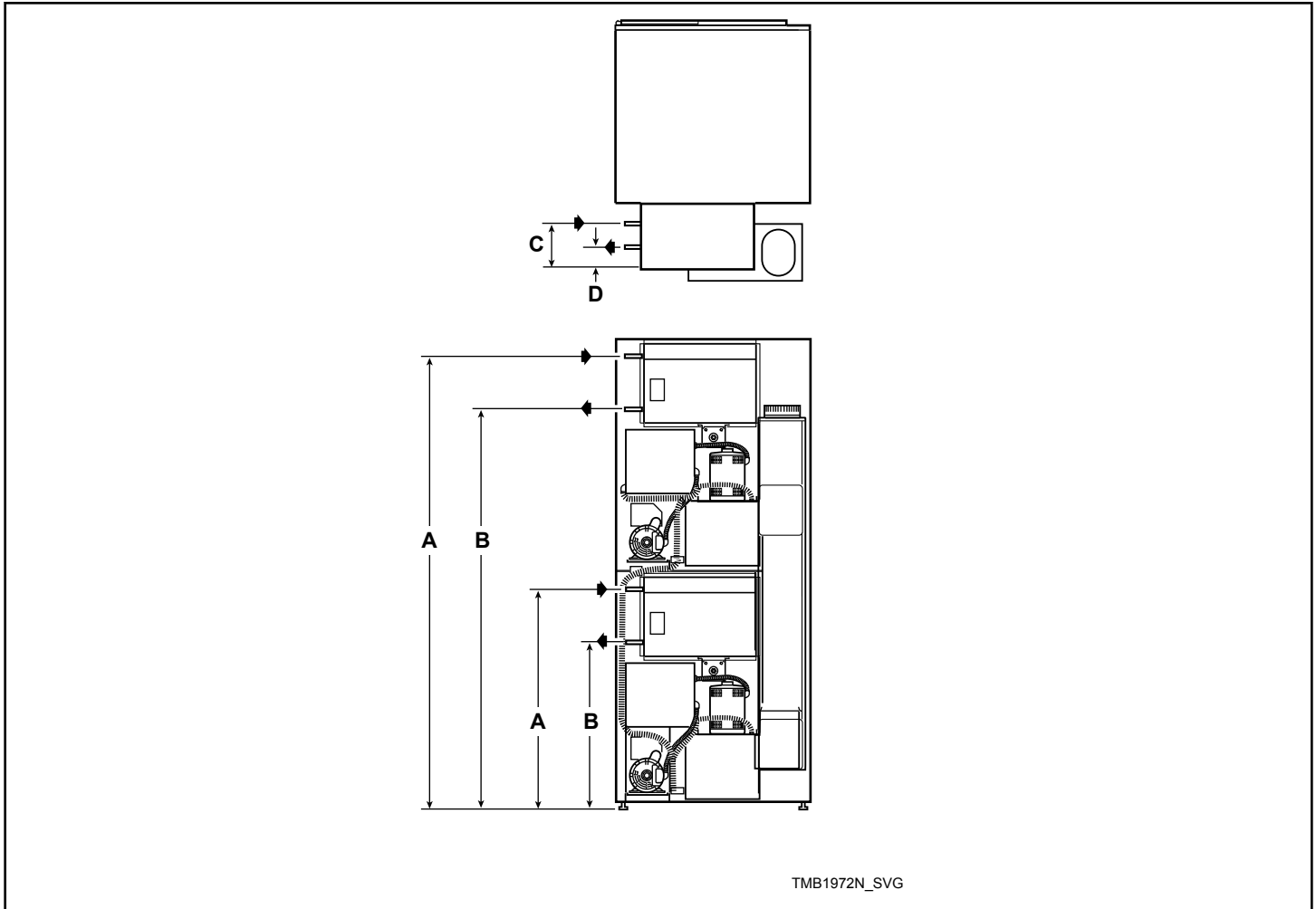

Models	Inlet		Outlet	
	A	C	B	D
T30 Series (Upper)	73.93 in. [1,877 mm]	6.29 in. [160 mm]	62.71 in. [1,592 mm]	2.39 in. [61 mm]
T30 Series (Lower)	36.35 in. [923 mm]	6.29 in. [160 mm]	25.13 in. [638 mm]	2.39 in. [61 mm]

**NOTE: All connections use 3/4 in. NPT pipe.**

# Installation

## Pre-Installation Inspection

Upon delivery, visually inspect the crate, carton and parts for any visible shipping damage. If the crate, carton, or cover is damaged or signs of possible damage are evident, have the carrier note the condition on the shipping papers before the shipping receipt is signed, or advise the carrier of the condition as soon as it is discovered.

Remove the crate and protective cover as soon as possible and check the items listed on the packing list. Advise the carrier of any damaged or missing articles as soon as possible. A written claim should be filed with the carrier immediately if articles are damaged or missing.

**IMPORTANT: Remove the yellow shipping wire tie securing the airflow switch.**

**IMPORTANT: Warranty is void unless tumble dryer is installed according to instructions in this manual. Installation should comply with minimum specifications and requirements detailed in this manual and applicable local gas fitting regulations, municipal building codes, water supply regulations, electrical wiring regulations, and any other relevant statutory regulations. Due to varied requirements, applicable local codes should be thoroughly understood and all pre-installation work arranged for accordingly.**

Materials Required (Obtain Locally)	
All Models	Fused disconnect switch or circuit breaker on 1 Phase models.  Circuit breaker on 3 Phase models.
Gas Models	One gas shut-off valve for gas service line to each tumble dryer.

*Table continues...*

Materials Required (Obtain Locally)	
Steam Models	One steam shut-off valve for steam service line to be connected upstream of solenoid steam valve.  Two steam shut-off valves for each condensate return line.  Flexible steam hoses with a 125 psig [pounds per square inch gauge] [862 kPa] working pressure for connecting steam coils. Refer to <i>Figure 27</i> for sizing and connection configurations.  Two steam traps for steam coil outlets to condensate return line.  Optional – Two vacuum breakers for condensate return lines.

**IMPORTANT: 3 Phase Only – Each tumble dryer must be connected to its own individual branch circuit breaker, not fuses, to avoid the possibility of “single phasing” and causing premature failure of the motor(s).**

## Location Requirements

The tumble dryer must be installed on a level floor. Floor covering materials such as carpeting or tile should be removed.

To assure compliance, consult local building code requirements. The tumble dryer must not be installed or stored in area where it will be exposed to water and/or weather.

**IMPORTANT: DO NOT block the airflow at the rear of the tumble dryer with laundry or other articles. Doing so would prevent adequate air supply to the combustion chamber of the tumble dryer.**

A typical tumble dryer enclosure is shown in *Figure 2*.

**IMPORTANT: Install tumble dryers with sufficient clearance for servicing and operation, refer to *Figure 2*.**

	<b>WARNING</b>
<p>To reduce the risk of severe injury, clearance of tumble dryer cabinet from combustible construction must conform to the minimum clearances, and/or local codes and ordinances.</p>	
W770R1	

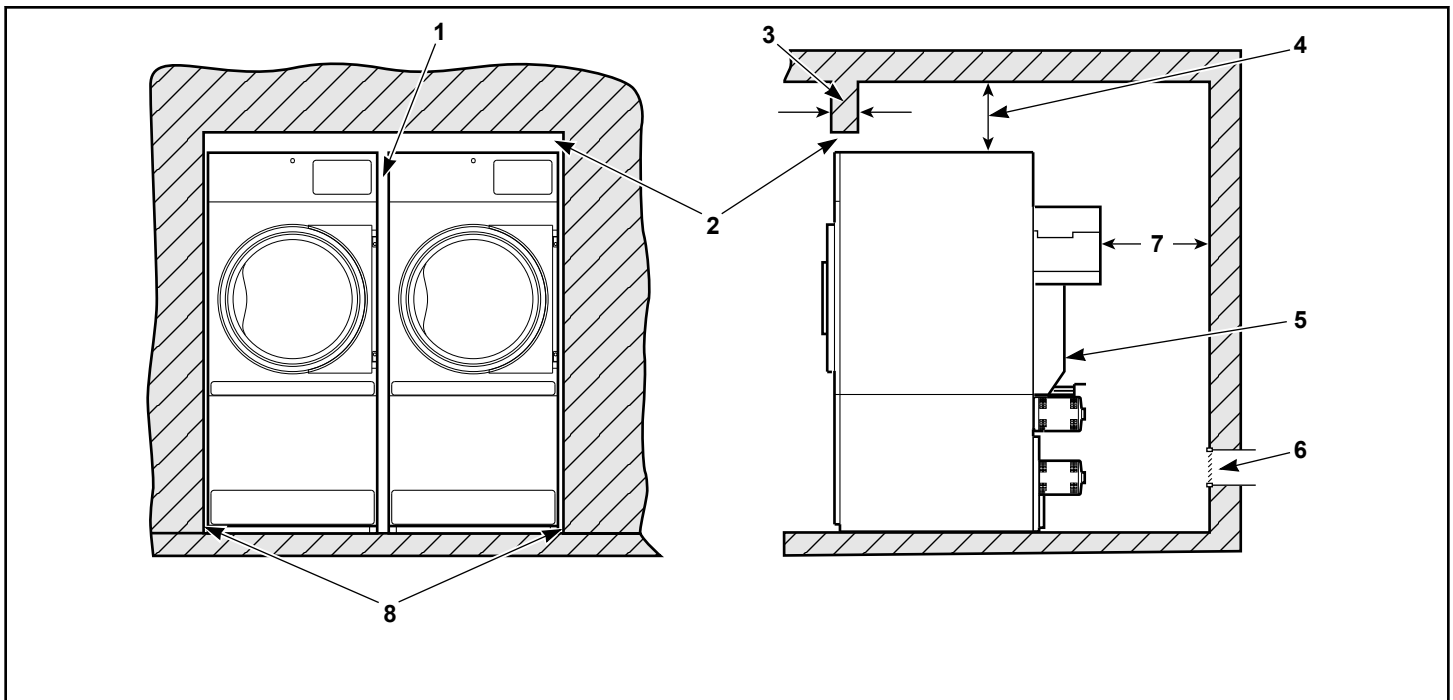

TMB2497N\_SVG

**NOTE: Shaded areas indicate adjacent structure.**

1. 0 in. [0 mm] minimum, 0.5 in. [13 mm] recommended between machines for removal or installation
2. Allow 2-4 in. [51-100 mm] opening at top of machine to aid in removal or installation. A removable trim piece may be used to conceal the opening; zero clearance allowed for trim.
3. 4 in. [100 mm] maximum header thickness
4. Minimum clearance permitted for remainder: 12 in. [305 mm]
5. Guard
6. Provision for make-up air
7. 24 in. [610 mm] minimum, 36 in. [914 mm] recommended for maintenance purposes
8. 0 in. [0 mm] minimum, 0.25 in. [6 mm] recommended for removal or installation purposes

Figure 2

## Position and Level the Tumble Dryer

1. Remove lint panel door, and unscrew the four shipping bolts (one at each corner).
2. Remove tumble dryer from pallet.  
**NOTE: DO NOT discard shipping bolts, they are used as machine leveling legs.**
3. Remove four nuts from the literature package, and screw one fully on to each leveling leg.
4. Screw the four leveling legs (bolts) back into the level adjusting fittings from the bottom.
5. Slide tumble dryer to its permanent location. Adjust the leveling legs until the unit is level, or no more than 0.13 inch [3.3 mm] higher in the front. Refer to *Figure 3*. Tumble dryer must not rock. Lock leveling legs with nuts previously installed.

**NOTE: The front of the tumble dryer should be slightly higher than the rear (approximately 0.13 inch [3.3 mm]). This will prevent the clothes, while tumbling, from wearing on the door glass gasket.**

**IMPORTANT: Keep tumble dryer as close to floor as possible. The unit must rest firmly on floor so weight of tumble dryer is evenly distributed.**

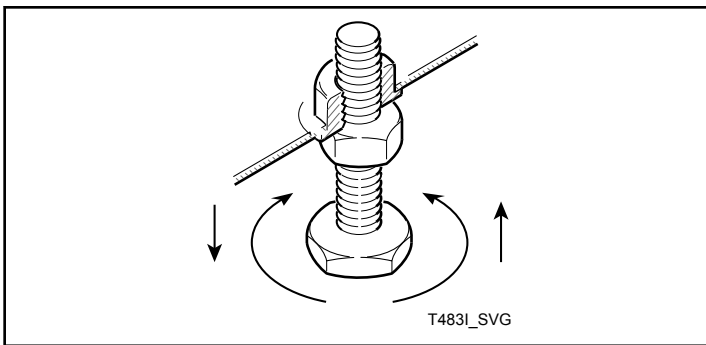

Figure 3

## Fire Suppression System (Optional Equipment)

	<b>WARNING</b>
<p><b>ELECTRICAL SHOCK HAZARD.</b> Electrical shock can result in death or serious injury. If the water dispensing system is activated, do not attempt to operate the tumble dryer. If the water dispensing system is activated, have the tumble dryer inspected by a qualified agency before operating the tumble dryer.</p>	
W879R1	

## Fifth Leveling Leg

The stacked tumble dryer has a fifth leveling leg which is shipped in the up position. The fifth leveling leg **MUST BE** installed properly on the lower left side of the blower housing to stabilize the tumble dryer. Refer to *Figure 4*.

After leveling with the four cabinet leveling legs, lower the fifth leveling leg so it contacts the floor, and then secure the screws.

	<b>CAUTION</b>
<p>The stacked tumble dryer has a 5th leveling leg on the blower housing. It is very important to properly adjust this leg. Unit is back heavy and could rock or tip.</p>	
W250R1	

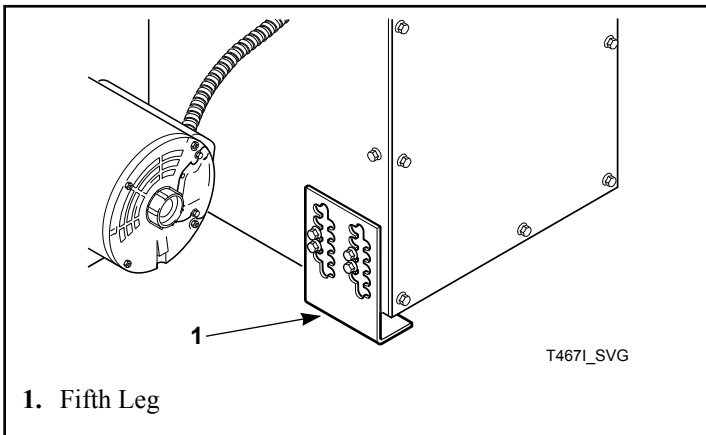

Figure 4

**IMPORTANT: Main supplies of electricity and water to the tumble dryer should remain on at all times for the fire suppression system to work.**

### Check Local Codes and Permits

Call your local water company or the proper municipal authority for information regarding local codes.

**IMPORTANT: It is your responsibility to have ALL plumbing connections made by a qualified professional to assure that the plumbing is adequate and conforms to local, state, and federal regulations or codes.**

**IMPORTANT: It is the installation or owner's responsibility to confirm that the necessary or required water, water pressure, pipe size, or connections are provided. Manufacturer assumes no responsibility if the fire suppression system is not connected, installed, or maintained properly.**

### Water Requirements

**IMPORTANT: Water must be supplied to the fire suppression system, or the fire suppression system will not operate as intended.**

To ensure the fire suppression system operates properly:

- Water supply requirements: 3/4 inch hose connections providing 15 gpm [57 lpm] minimum flow; Water pressure 20 psi [138 kPa] minimum, 120 psi [827 kPa] maximum; water temperature 40°F [4.5°C] minimum, 120°F [49°C] maximum must be maintained at all times.
- Electric power to the tumble dryer must be provided at all times.
- Perform preventative maintenance checks every month. Refer to Operation/Maintenance Manual.

**NOTE: Water pressure under 20 psi [138 kPa] will cause low flow at water solenoid valve.**

If the rear of the tumble dryer or the water supply is located in an area where it will be exposed to cold/freezing temperatures, provisions must be made to protect these water lines from freezing.

**IMPORTANT:** Temperature of the water supply must be kept between 40°F and 120°F [4.5°C and 49°C]. If water in the supply line or water solenoid valve freezes, the fire suppression system will not operate.

**IMPORTANT:** If temperature sensors inside the tumble dryer register a temperature below 40°F [4.5°C], the fire suppression system control will lock out. This feature protects against operation of the tumble dryer with a possible frozen water supply. Only when the temperature sensors register a temperature 40°F [4.5°C] or above will the machine reset for operation.

For installations where the tumble dryer must operate below 40°F [4.5°C], a cold weather fire suppression system relocation kit (part no. 44340301) is available. Refer to the instructions provided in the kit for proper installation.

**IMPORTANT:** Flexible supply line/coupling must be used. Solenoid valve failure due to hard plumbing connections will void the warranty. It is recommended that a filter or strainer be installed in the water supply line.

### Water Connections

Connect machine to a backflow preventer (vacuum breaker) before connecting to the public water main in all countries where local regulations require specific water approval certificates.

Two hoses and a Y-valve are provided with the tumble dryer to allow for connection of water supply to tumble dryer. The water connections are made to the bushings of the water solenoid valve, located on the rear of the tumble dryer. The Y-valve provides a single female hose connection (Standard US 3/4-11 1/2 NH thread). Refer to *Figure 5* and *Figure 6*.

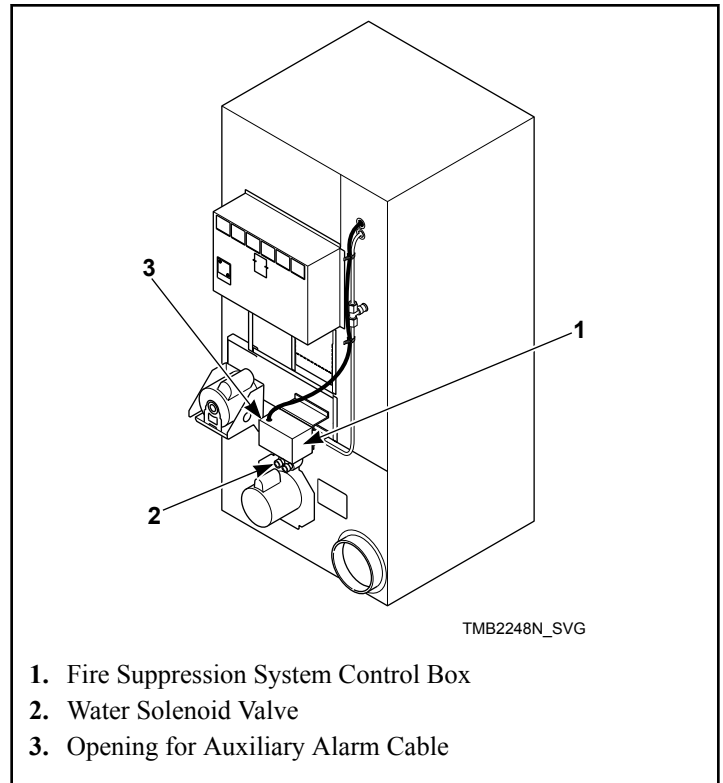

Figure 5

To connect the two hoses (supplied with tumble dryer), insert rubber washers (from literature pack) in water inlet hose couplings. Refer to *Figure 6*.

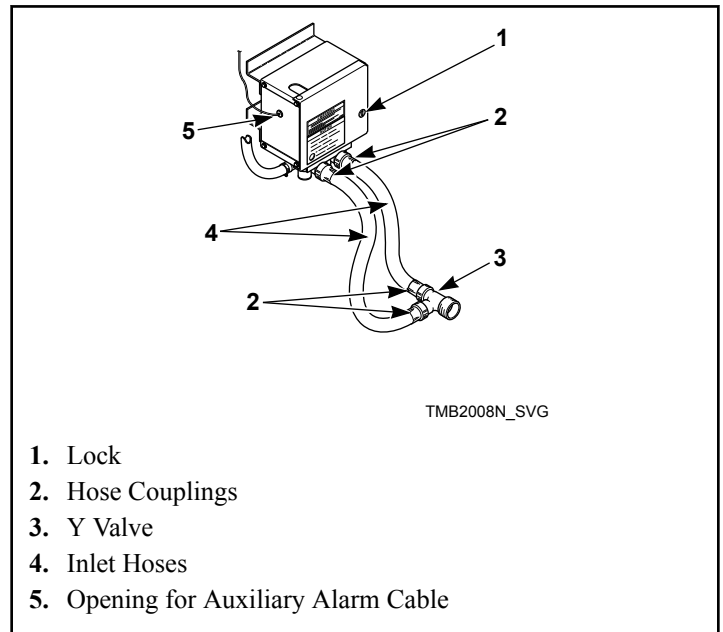

Figure 6

Connect inlet hoses to water supply. Flush the lines for approximately two minutes to remove any foreign materials that could clog the screens in the water mixing valve. This is especially important when installing a tumble dryer in a newly constructed or

renovated building. Then connect the hoses to the Y-valve; connect the Y-valve to the connections at the rear of the tumble dryer.

**IMPORTANT:** Thread hose couplings onto valve connections finger tight, then turn 1/4 turn with pliers. Do not cross thread or overtighten couplings.

**IMPORTANT:** Hoses and other natural rubber parts deteriorate after extended use. Hoses may develop cracks, blisters or material wear from the temperature and constant high pressure they are subjected to. All hoses should be checked on a yearly basis for any visible signs of deterioration. Any hose showing the signs of deterioration listed above should be replaced immediately. All hoses should be replaced every five years.

**NOTE:** Longer inlet hoses are available (as optional equipment at extra cost) if the hoses supplied with the tumble dryer are not long enough for installation. Order hoses as follows:

Part No. 20617 Inlet hose 8 feet [2.44 m]

Part No. 20618 Inlet hose 10 feet [3.05 m]

**NOTE:** Replacement outlet hoses are available (at extra cost). Order 44073304 Hose, 14 in. [36 cm].

**Electrical Requirements**

	<b>WARNING</b>
<p><b>Electrical power must be provided to tumble dryer at all times. The fire suppression system will be inoperative if the main electrical power supply is disconnected.</b></p>	
W690R1	

No independent external power source or supply connection is necessary. Power to operate the 24 Volt fire suppression system is from the rear junction/contactor box.

**Auxiliary Alarm**

The fire suppression system provides an auxiliary output signal when the system is activated. During tumble dryer installation, you have the option to connect a separate alarm system to this auxiliary output. Potential uses of the auxiliary output include, but are not limited to: (1) sounds an alarm, (2) activates a building sprinkler system, (3) notifies a fire department, etc. Use of the auxiliary output is not required for the fire suppression system to operate, but may be used for additional protection.

The connection to the auxiliary output is made through the FS-1 and FS-2 fast-on connections inside the fire suppression control box. Refer to *Figure 7*. The relay is rated for 24 VAC, 5.2 Amp, sealed current.

**NOTE:** The auxiliary output is activated during fire suppression system maintenance test sequence. Consider this fact prior to your system test every three months. (Example: If the external system uses the auxiliary output to call the fire department, inform the fire department before and after the fire suppression system maintenance test.)

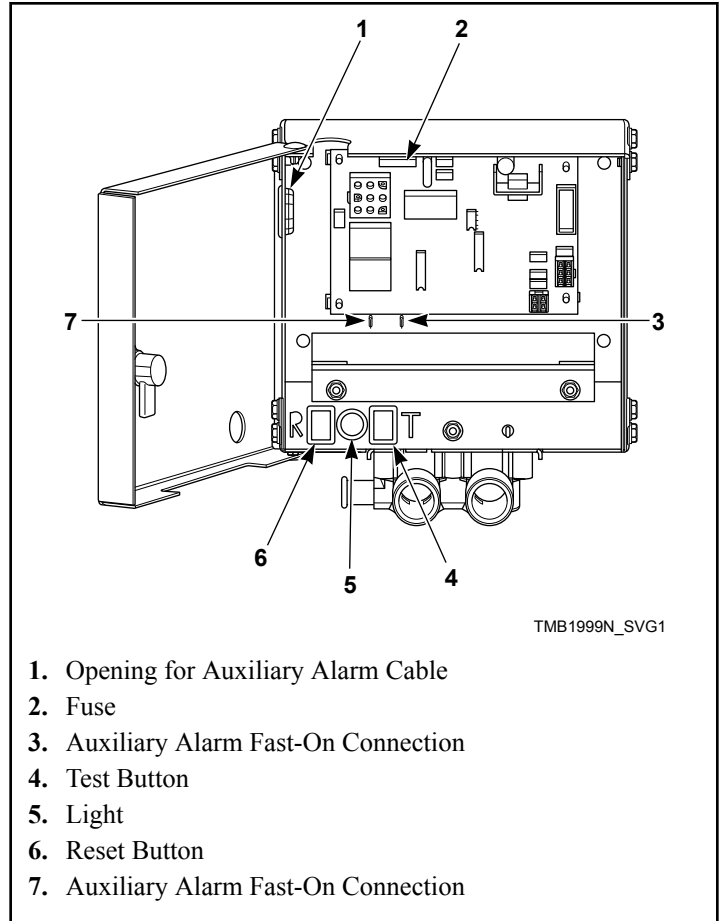

1. Opening for Auxiliary Alarm Cable
2. Fuse
3. Auxiliary Alarm Fast-On Connection
4. Test Button
5. Light
6. Reset Button
7. Auxiliary Alarm Fast-On Connection

Figure 7

**To Reverse the Loading Door (025, 030, 035 and 055 Series)**

The tumble dryer is delivered with a right hinged door, but the door can be changed to a left hinged position.

1. Disconnect power supply to tumble dryer.
2. Unlock and remove control panel. Remove two control assembly mounting screws from right side. Swing open control to access upper flange right guide lug assembly. Refer to *Figure 8*.
3. Remove lint panel.

**IMPORTANT:** Support door and hinge assembly securely to prevent it from dropping once side screws are removed from door hinge lug.



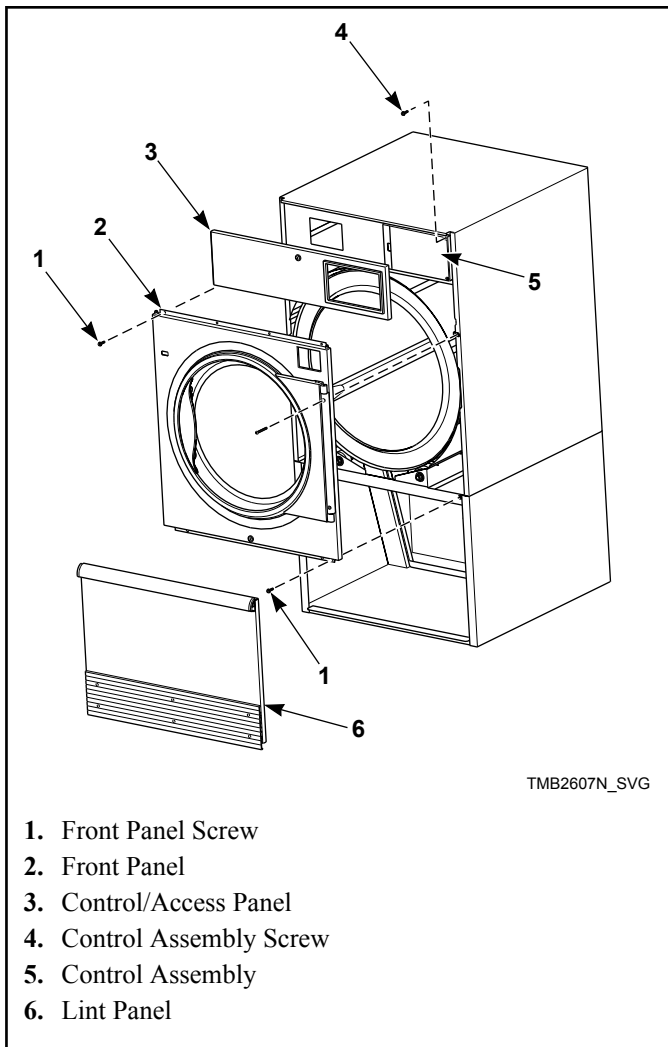

Figure 8

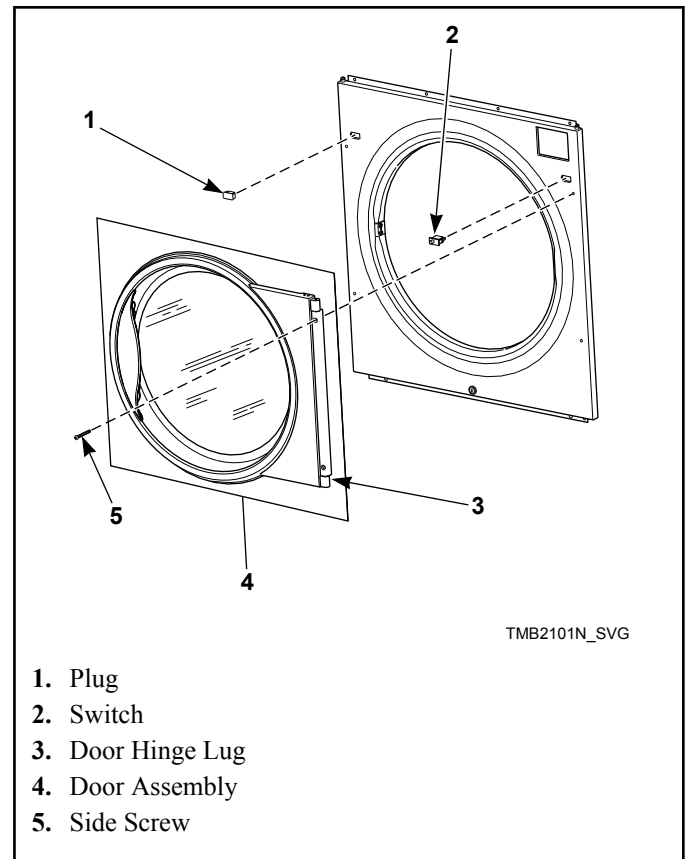
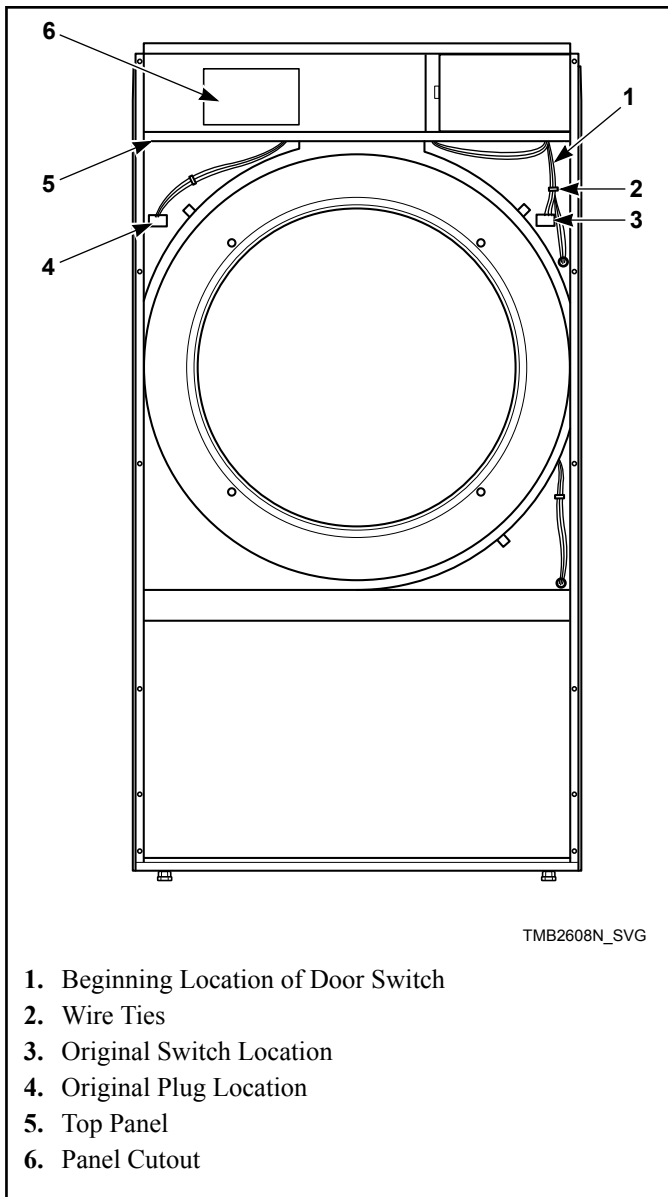

Figure 9

4. Remove four front panel screws. Refer to *Figure 8* . Keep door hinge cams in place on door hinge lug. Pull lug and door assembly off as one piece. Refer to *Figure 9* .
5. Remove remaining front panel screws. Refer to *Figure 8* . Disconnect door switch harness from switch. Take off front panel. Refer to *Figure 9* .
6. Exchange switch and plug locations. Depress tabs with an adjustable pliers to remove plug and switch from front panel. Reinstall switch, orienting button toward center of machine. Reinstall plug in switch's previous location. Refer to *Figure 9* .

**IMPORTANT: Door switch must be oriented correctly in front panel receiving hole or tumble dryer will not operate.**

7. Cut wire ties to remove door switch harness bundle. Be careful not to damage harness wires. Refer to *Figure 10* .
8. Reroute door switch harness up through the hole in the right side of the top panel. Use the panel cutout opening to then put harness down through the hole in the left side of the top panel and into the upper left corner of the cylinder enclosure.



1. Beginning Location of Door Switch
2. Wire Ties
3. Original Switch Location
4. Original Plug Location
5. Top Panel
6. Panel Cutout

Figure 10

9. Place front panel on machine, loosely attach four bottom screws. Connect door switch harness to switch in new location. Install door assembly and four front panel side screws loosely. Refer to *Figure 11*.
10. Check lint panel fit, adjusting front panel up or down as required. Tighten four front panel side screws to maintain position of front panel for proper lint panel clearance.
11. Remove lint panel. Fully tighten bottom screws on front panel.
12. Reinstall top screws and guide lugs.
13. Adjust door catch if necessary to allow 8 – 15 pounds [35.6N – 66.7N] pull at center of handle.
14. Reinstall control assembly using mounting screws.
15. Reinstall control panel and lint panel.

**IMPORTANT:** Restore power to tumble dryer and test for proper operation of loading door switch. Refer to *Loading Door Switch* section for adjustment procedure. Tumble dryer should not start with door open; an operating tumble dryer should stop when door is opened.

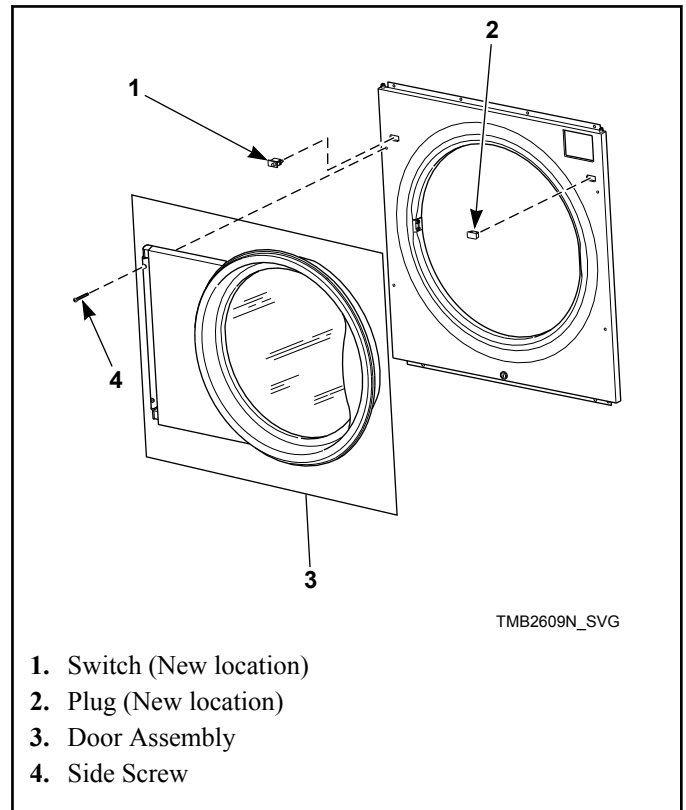

1. Switch (New location)
2. Plug (New location)
3. Door Assembly
4. Side Screw

Figure 11

**NOTE:** If machine is converted back to right hand hinge operation, the door switch harness must be rerouted. Harness must be rebundled with the lint panel switch harness. Wire ties must be used to secure harnesses. Wire ties (Part No. 55881) can be ordered from Genuine Parts.

## Before Placing Tumble Dryer into Service

1. Remove or open all panels and check accessible bolts, nuts, screws, terminals and fittings for tightness.
2. Replace all panels and guards.
3. Remove and discard wire tie from the airflow switch so it can swing freely. Refer to *Figure 12*.

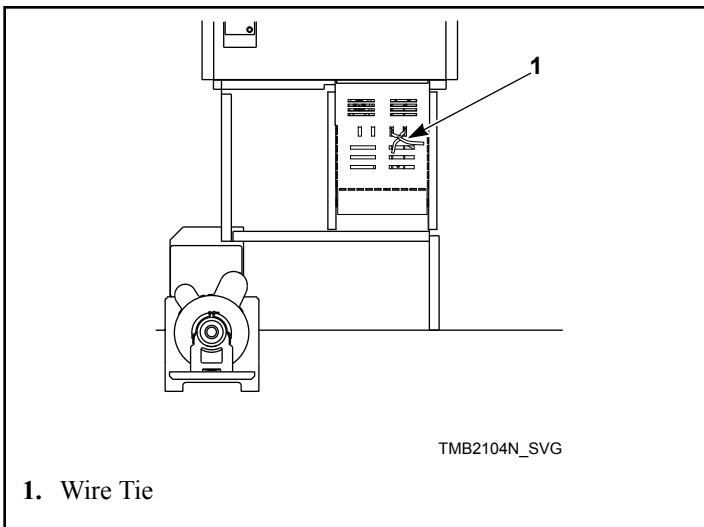

Figure 12

4. Turn on electrical supply to tumble dryer.
5. Open the supply valve for gas or steam heated tumble dryers.
6. After performing the previous checks, start the tumble dryer by pressing START. (Refer to the Operating section for detailed instructions.) Release the start button and open the loading door. The cylinder should stop rotating within seven seconds after the door is opened a maximum of 2 inches [51 mm]. If it does not, adjust the loading door switch. Refer to Adjustments section.
7. **Gas Tumble Dryers:** Start the tumble dryer and check the burner flame. Adjust the air inlet shutter as required. Refer to Adjustments section.

**IMPORTANT: The electronic ignition system will attempt to light the gas by sparking for the “trial for ignition” period. If gas does not ignite within this period, the ignition control will go into a safety lock-out and the valve will no longer open until the control is reset. It may be necessary to retry several times to bleed air from the gas lines. To reset, open and close the loading door and restart tumble dryer. If lockout condition persists, check that the manual gas shut-off valve is in the ON position and that the gas service is properly connected. If condition still persists, remove tumble dryer from service.**

8. Load the cylinder with a full load of clean rags and run to remove oil or dirt from cylinder.
9. Check the airflow switch operation by opening the lint panel; be sure to remove shipping tape from airflow switch prior to operation. Temporarily tape down the lint panel safety switch located behind the upper left corner of the lint panel. The heating systems should shut off when the lint panel is opened a maximum of 1.5 inches [38 mm].

The airflow switch operation may be affected by shipping tape still in place, lack of make-up air, or an obstruction in the exhaust duct. These should be checked. If there is a problem, contact an authorized service person.



## WARNING

**Do not operate tumble dryer if airflow switch is faulty. An explosive gas mixture could collect in tumble dryer if airflow switch does not operate properly.**

W407R1

10. Wipe out the cylinder using an all-purpose cleaner or detergent and water solution. Refer to *Figure 13*.

**IMPORTANT: The use of chlorine bleach for removing any discoloration should be avoided because bleach could damage the finish.**

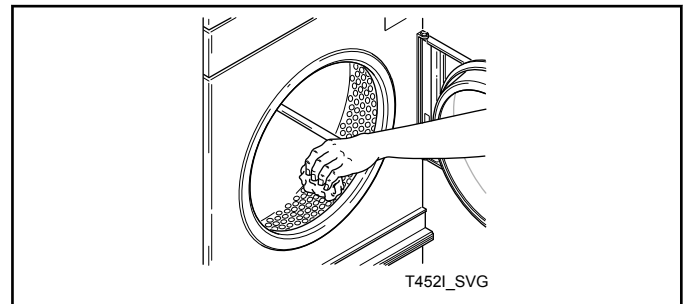

Figure 13

Models		Prepurge Time (seconds)	Trial for Ignition (seconds)	Reset Lockout Condition By:
Models through 3/10/13	CE and Australia	18	10	025, 030, 035, 055: Press reset button on rear of machine T30, T45: Press lighted reset button in rear contactor box
	All others	1-3	10	Open loading door
Models starting 3/11/13 through 12/31/13	CE	1	10 (attempts to ignite 3 times)	For models with EO, RE, RU or UO control suffixes: Press start on control keypad. For models with all other control suffixes: Press and hold reset button on junction box until light goes out.
Models Starting 3/11/13	Non-CE and non-Australian	1	10 (attempts to ignite 3 times)	Open loading door
Models starting 3/11/13 through 7/31/13	Australia	18	10	025, 030, 035, 055: Press reset button on rear of machine T30, T45: Press lighted reset button in rear contactor box
Models starting 8/1/13	Australia	23	23	For models with EO, RE, RU or UO control suffixes: Press start on control keypad. For models with all other control suffixes: Press and hold ignition control reset button.
Models Starting 1/1/14	CE			

If the tumble dryer does not meet ANY of the listed requirements, remove tumble dryer from use. Refer to Removing Tumble Dryer from Service section.

**Required for CE Models Only**

Once machine is installed, please be sure to complete the following items:

- Review and verify machine operation with customer.
- Leave all literature and a signed Declaration of Conformity with customer.
- Review machine warranty information with customer.

- Apply warning sticker on front panel of machine, in language appropriate to country of sale (included in literature packet).

**Installing CE Gas Drying Tumble Dryer**

**General Information**

This information is to be used when installing gas tumble dryers in countries and/or on gases different than the machine’s factory configuration. Tumble Dryers are supplied from the factory for

operation on Natural Gas 1000 Btu/cu. ft. [8914 kcal/m<sup>3</sup>], or L.P. Gas 2500 Btu/cu. ft. [22,250 kcal/m<sup>3</sup>], with natural gas group H/E, designation G20 and L.P. gas group B/P, designation G30. To install machines in any other country, or on any other gas, requires some level of modification.

Machines are built in two different configurations:

- Natural Gas – regulated/governor
- Liquefied Petroleum (L.P.) Gas – not regulated/no governor

For converting models from Natural Gas to L.P. Gas, order M405434 L.P. Valve Conversion Kit and correct orifice. Refer to *CE Orifices*.

Serial plates supplied from the factory are configured for GB/IE/PT/ES/IT/GR/LU/CH/BE. These instructions pertain to the situations when the country of use or gas supply is different than that on the serial plate. If applicable, peel off the appropriate country sticker (included with machine) and apply it to the serial plate over the existing country information.

**CE Orifices**

These instructions are only valid if the following country code is on the appliance: GB/IE/PT/ES/IT/GR/LU/CH/BE. If this code is not present on the appliance, it is necessary to refer to the technical instructions which will provide the necessary information concerning the modification of the appliance to the condition of use for the country.

Before installation, check that the local distribution conditions, nature of gas and pressure, and the adjustment of the appliance are compatible.

*Table 1* describes the different gases that are available in different CE countries, and how the machines need to be configured to operate with those gases. In the CE, there are Natural Gas configurations that do not allow for machine regulation and L.P. Gas configurations that must be regulated. For L.P. Gas, third family B/P at 50 mbar [5 kPa], order Regulated Natural Gas machines and convert according to *Table 1*.

Gas Type	Gas Family	Gas Group	Gas Designation	Supply Pressure in. wc [mbar, kPa]	Manifold Pressure in. wc [mbar, kPa]	Capacity Model	Orifice Diameter in. [mm]	Orifice Part No.	Quantity
Natural Gas	Second	I <sub>2H(E)</sub>	G20	8/10 [20/25, 2.0/2.5]	3.25 [8, 0.8]	25	0.1540 [3.9]	M401020	1
						30	0.1570 [4.0]	M402996	1
						T30	0.1570 [4.0]	M402996	2
						35	0.1820 [4.6]	M411371	1
						T45	0.1820 [4.6]	M411371	2
						55	0.2040 [5.2]	M402993	1

Table 1 *continues...*

Gas Type	Gas Family	Gas Group	Gas Designation	Supply Pressure in. wc [mbar, kPa]	Manifold Pressure in. wc [mbar, kPa]	Capacity Model	Orifice Diameter in. [mm]	Orifice Part No.	Quantity
Natural Gas	Second	I <sub>2L</sub>	G25	10 [25, 2.5]	4.4 [11, 1.1]	25	0.1540 [3.9]	M401020	1
						30	0.1570 [4.0]	M402996	1
						T30	0.1570 [4.0]	M402996	2
						35	0.1820 [4.6]	M411371	1
						T45	0.1820 [4.6]	M411371	2
						55	0.2040 [5.2]	M402993	1
Natural Gas	Second	I <sub>2E+</sub>	G20	8 [20, 2.0]	Un-regulated	25	0.1220 [3.1]	70070903	1
						30	0.1299 [3.3]	44253801	1
						T30	0.1299 [3.3]	44253801	2
						35	0.1440 [3.7]	M400998	1
						T45	0.1440 [3.7]	M400998	2
						55	0.1695 [4.3]	M402988	1

Table 1 *continues...*

Gas Type	Gas Family	Gas Group	Gas Designation	Supply Pressure in. wc [mbar, kPa]	Manifold Pressure in. wc [mbar, kPa]	Capacity Model	Orifice Diameter in. [mm]	Orifice Part No.	Quantity
LP	Third	I <sub>3B/P</sub>	G30	11.25/12 [28/30, 2.8/3.0]	Un-regulated	25	0.0820 [2.1]	M401027	1
						30	0.0866 [2.2]	70070906	1
						T30	0.0866 [2.2]	70070906	2
						35	0.0980 [2.5]	M406361	1
						T45	0.0935 [2.4]	M403017	2
						55	0.1200 [3.0]	M401017	1
LP	Third	I <sub>3B/P</sub>	G30	14.9/20 [37/50, 3.7/5.0]	12 [30, 3.0]	25	0.0820 [2.1]	M401027	1
						30	0.0866 [2.2]	70070906	1
						T30	0.0866 [2.2]	70070906	2
						35	0.0980 [2.5]	M406361	1
						T45	0.0935 [2.4]	M403017	2
						55	0.1200 [3.0]	M401017	1

Table 1 *continues...*

Gas Type	Gas Family	Gas Group	Gas Designation	Supply Pressure in. wc [mbar, kPa]	Manifold Pressure in. wc [mbar, kPa]	Capacity Model	Orifice Diameter in. [mm]	Orifice Part No.	Quantity
LP	Third	I <sub>3+/3P</sub>	G30 /G31	11.25/14.9 [28/37, 2.8/3.7]	Un-regulated	25	0.0820 [2.1]	M401027	1
						30	0.0866 [2.2]	70070906	1
						T30	0.0866 [2.2]	70070906	2
						35	0.0980 [2.5]	M406361	1
						T45	0.0935 [2.4]	M403017	2
						55	0.1200 [3.0]	M401017	1

Table 1

**Properties of CE Gases**

Gas Type	Gas Family	Group	Gas Description	Gas Designation	Wi	Hi	Ws	Hs	d	
					Wobbe Index (net)	Heating Value (net)	Wobbe Index (gross)	Heating Value (gross)	Density	
					Btu/ft <sup>3</sup> [MJ/m <sup>3</sup> ]	Btu/ft <sup>3</sup> [MJ/m <sup>3</sup> ]	Btu/ft <sup>3</sup> [MJ/m <sup>3</sup> ]	Btu/ft <sup>3</sup> [MJ/m <sup>3</sup> ]		
Natural Gas	Second	I <sub>2H,E</sub>	Not Applicable	G20	1226 [45.67]	913 [34.02]	1362 [50.72]	1014 [37.78]	0.555	
		I <sub>2E+</sub>	2H							
		I <sub>2L</sub>	Not Applicable	G25	1004 [37.38]	785 [29.25]	1115 [41.52]	872 [32.49]		0.612
		I <sub>2E+</sub>	2L							

Table 2 continues...



Gas Type	Gas Family	Group	Gas Description	Gas Designation	Wi	Hi	Ws	Hs	d
					Wobbe Index (net)	Heating Value (net)	Wobbe Index (gross)	Heating Value (gross)	Density
					Btu/ft <sup>3</sup> [MJ/m <sup>3</sup> ]	Btu/ft <sup>3</sup> [MJ/m <sup>3</sup> ]	Btu/ft <sup>3</sup> [MJ/m <sup>3</sup> ]	Btu/ft <sup>3</sup> [MJ/m <sup>3</sup> ]	
LP	Third	I <sub>3B/P</sub>	Not Applicable	G30	2164 [80.58]	3117 [116.09]	2345 [87.33]	3378 [125.81]	2.075
		I <sub>3+</sub>	Pure Butane						
		I <sub>3+</sub>	Pure Propane	G31	1898 [70.69]	2363 [88]	2063 [76.83]	2568 [95.65]	1.55
		I <sub>3P</sub>	LPG with Propane						

Table 2

## Changing Gas Configuration

1. Refer to table in *Gas Requirements* section to determine which conversion kit to use.
2. Determine the necessary conversion operations to convert from the factory-supplied configuration to the desired configuration.
3. Perform the conversions required so the tumble dryer is properly configured for the desired country and gas. Refer to the conversion kit instructions supplied with the kit and the following sections:
  - How to Change Burner Orifice Size
  - How to Adjust Gas Valve Governor/Regulator

	<b>WARNING</b>
<p><b>When converting the tumble dryer to a different gas or pressure, first verify that the supply inlet pressure is equipped with a pressure regulator (located ahead of the tumble dryer) that will maintain the gas supply at the inlet pressure specified.</b></p>	
W430R1	

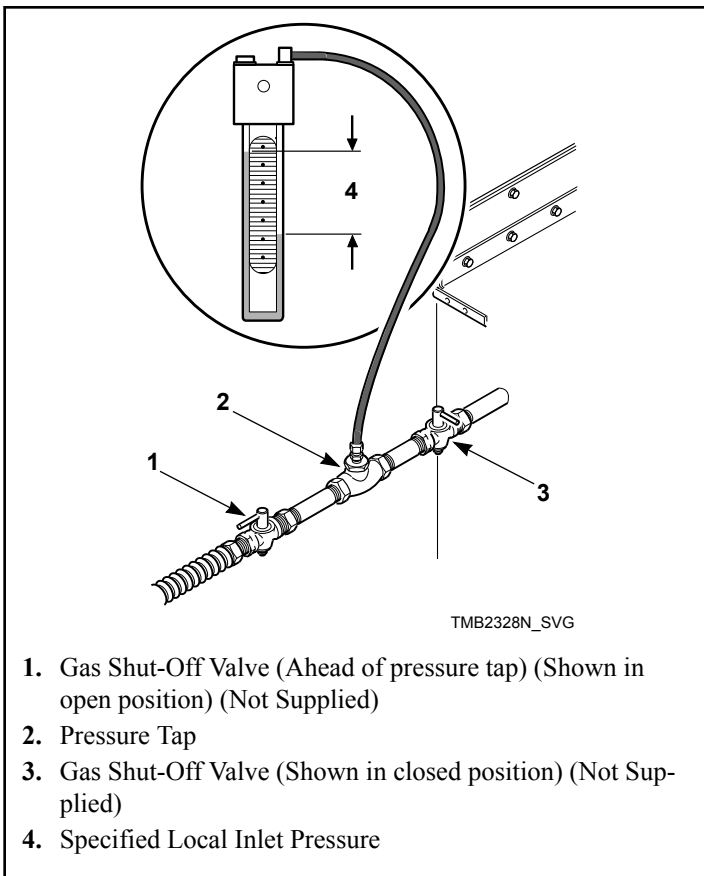

Figure 14

### How to Change Burner Orifice Size

1. Disconnect electrical power from tumble dryer. Close gas shut-off valve to tumble dryer. Refer to *Figure 14* .
2. Remove spud holder. Unscrew spud holder nut near gas valve. Remove the burner orifice(s) from spud holder. Refer to *Figure 15* and *Figure 16* .
3. Install the new, correct burner orifice(s). Refer to *Figure 17* and *Table 1* . Torque each to 9 – 10 Nm.

### Specific Conversion Procedures

#### How to Convert Gas Valve from Regulated to Unregulated

**NOTE: Conversion from regulated to unregulated is only needed when regulated tumble dryers were ordered, but unregulated tumble dryers were needed.**

1. Disconnect electrical power from tumble dryer. Close gas shut-off valve to tumble dryer. Refer to *Figure 14* .
2. Follow instructions in Conversion Kit Part No. 431485.

**NOTE: These kits do not contain any burner orifices.**

3. Replace burner orifice(s) as per *Table 1* .
4. If applicable, peel off the appropriate conversion sticker (included with tumble dryer) and apply it to the serial plate over the “ADJUSTED FOR \_\_\_\_\_ GAS: \_\_\_\_\_” information.
5. Commission tumble dryer for use.

4. Reinstall spud holder assembly to gas valve, making certain burner orifice(s) are in line with burner tube opening. Refer to *Figure 17* .
5. Commission tumble dryer for use.

**NOTE: Blank burner orifices are Part No. M400995.**

## Models Through 12/31/13

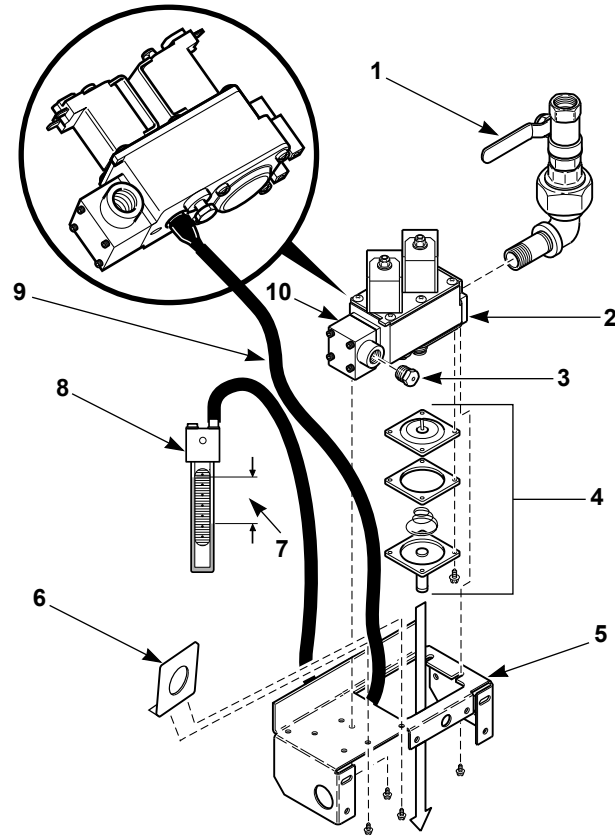

TMB2252N\_SVG

1. Gas Shut-Off Valve (Shown in closed position) (Not Supplied)
2. Gas Valve
3. Burner Orifice
4. Regulator Adjusting Housing and Gasket (Regulated version shown)
5. Gas Valve Bracket
6. Part No. 70201901 025 Series Natural Gas L.P. Orifice Plate (For use on 025 Series Natural Gas Models L.P. only)
7. Required Burner Manifold Pressure
8. Manometer
9. Connect Over Loosened Slotted Pressure Tap Screw in Bottom of Gas Valve
10. Spud Holder

Figure 15

**Models Starting 1/1/14**

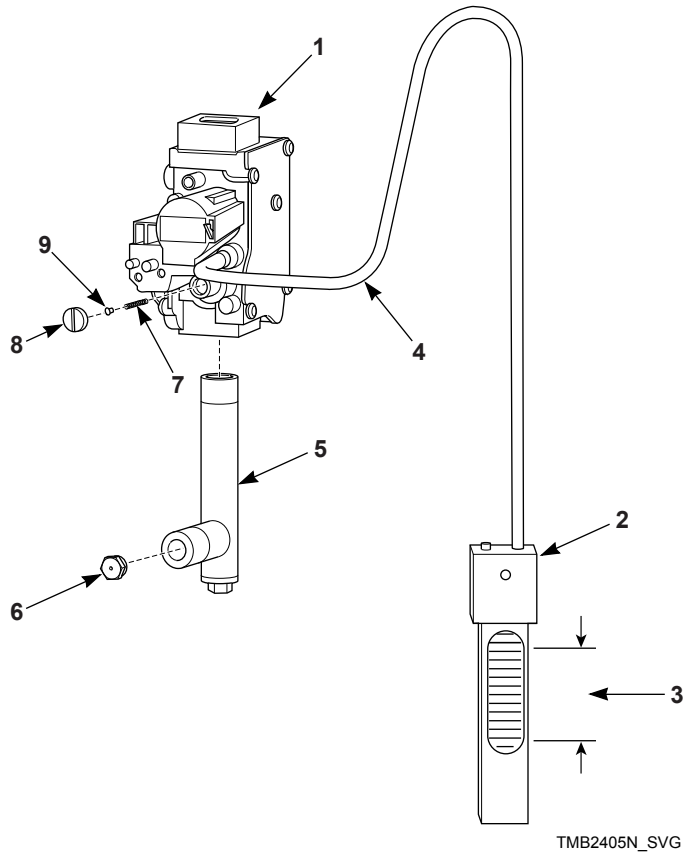

1. Gas Valve
2. Manometer
3. Required Burner Manifold Pressure
4. Connect Over Loosened Hex Pressure Tap Screw
5. Orifice Adapter
6. Burner Orifice
7. Spring
8. Cap
9. Pin

Figure 16

**How to Adjust Gas Valve Governor/Regulator**

1. Check gas burner orifice (manifold) pressure as follows. Refer to *Figure 15* and *Figure 16*.
2. Remove screw plug from pressure tap.
3. Connect a “U”-tube manometer (or similar pressure gauge) to the burner orifice (manifold) pressure tap.
4. Start tumble dryer and note pressure once flame is burning. Remove regulator cap and adjust regulator screw until the burner orifice pressure per applicable table is achieved. Replace regulator cap. Refer to *Figure 15* and *Figure 16*.
5. Commission tumble dryer for use.

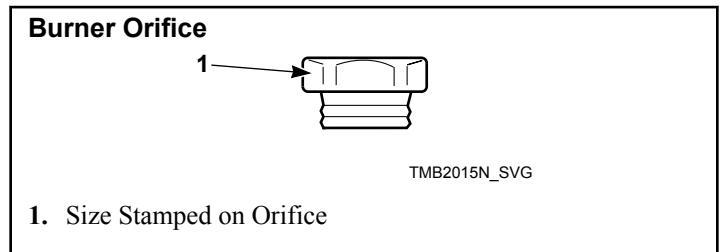



1. Size Stamped on Orifice

Figure 17

# Exhaust Requirements

## Exhaust Requirements

	<b>CAUTION</b>
<p><b>Risk of fire. A clothes dryer produces combustible lint. Exhaust outdoors. Consult technical instructions for detailed exhaust specifications.</b></p>	
W933	

	<b>WARNING</b>
<p><b>To reduce the risk of fire, DO NOT use plastic or thin foil ducting to exhaust the tumble dryer.</b></p>	
W773R1	

	<b>WARNING</b>
<p><b>To reduce the risk of fire and accumulation of combustible gases, DO NOT exhaust tumble dryer air into a window well, gas vent, chimney or enclosed, unventilated area such as an attic wall, ceiling, crawl space under a building, or concealed space of a building.</b></p>	
W059R1	

## Layout

Whenever possible, install tumble dryers along an outside wall where duct length can be kept to a minimum, and make-up air can be easily accessed. Construction must not block the airflow at the rear of the tumble dryer. Doing so would prevent adequate air supply to the tumble dryer combustion chamber.

## Make-Up Air

A tumble dryer is forced air exhausted and requires provisions for make-up air to replace air exhausted by tumble dryer.

**IMPORTANT: Do not obstruct flow of combustion and ventilation air.**

<b>Required Make-Up Air Opening (to the outside) for Each Tumble Dryer, in.<sup>2</sup> [ cm<sup>2</sup>]</b>	
Model	Opening
Standard 025/030 Series	110 [710]
Eco 025 Series	65 [420]
Standard 035/055 Series	144 [930]
Eco 035 Series	120 [775]
Standard T30 Series	220 [1,420]
Eco T30 Series	180 [1,160]
T45 Series	288 [1,860]

Make-up air openings with louvers will restrict airflow. The opening must be increased to compensate for area taken up and restrictions created by louvers. Contact the louver manufacturer for the exact specifications.

Make-up air openings in rooms containing tumble dryer(s) and/or gas fired hot water heater or other gravity vented appliances must be increased sufficiently to prevent downdrafts in any of the vents when all tumble dryers are in operation. Do not locate gravity vented appliances between tumble dryer(s) and make-up air openings. If it is necessary to duct make-up air to tumble dryer(s), increase area of duct work by 25% to compensate for restrictions in air movement.

## Venting

	<b>WARNING</b>
<p><b>To reduce the risk of fire due to increased static pressure, we do not recommend installation of in-line secondary lint filters or lint collectors. If secondary systems are mandated, frequently clean the system to assure safe operation.</b></p>	
W749	

**IMPORTANT: Installing in-line filters or lint collectors will cause increased static pressure. Failure to maintain the secondary lint system will decrease tumble dryer efficiency and may void machine warranty.**

For maximum efficiency and minimum lint accumulation, tumble dryer air must be exhausted to the outdoors by the shortest possible route.

Proper sized exhaust ducts are essential for proper operation. All elbows should be sweep type. Exhaust ducts must be assembled so the interior surfaces are smooth, so the joints do not permit the accumulation of lint. DO NOT use plastic, thin foil or Type B flexible ducts - rigid metal ducts are recommended. Use exhaust ducts made of sheet metal or other noncombustible material. DO NOT use sheet metal screws or fasteners on exhaust pipe joints which extend into the duct and catch lint. Use of duct tape or pop-rivets on all seams and joints is recommended, if allowed by local codes.

Verify that old ducts are thoroughly cleaned out before installing new tumble dryer(s).

**NOTE: Exhaust ducts must be constructed of sheet metal or other noncombustible material. Such ducts must be equivalent in strength and corrosion resistance to ducts made of galvanized sheet steel not less than 0.0195 inches [0.495 mm] thick.**

Where the exhaust duct pierces a combustible wall or ceiling, the opening must be sized per local codes. The space around the duct may be sealed with noncombustible material. Refer to *Figure 18*.

**IMPORTANT: For best performance provide an individual exhaust duct for each tumble dryer. Do not install a hot water heater in a room containing tumble dryers. It is better to have the water heater in a separate room with a separate air inlet.**

	<b>WARNING</b>
<b>Improperly sized or assembled ductwork causes excess back pressure which results in slow drying, lint collecting in the duct, lint blowing back into the room, and increased fire hazard.</b>	
W355	

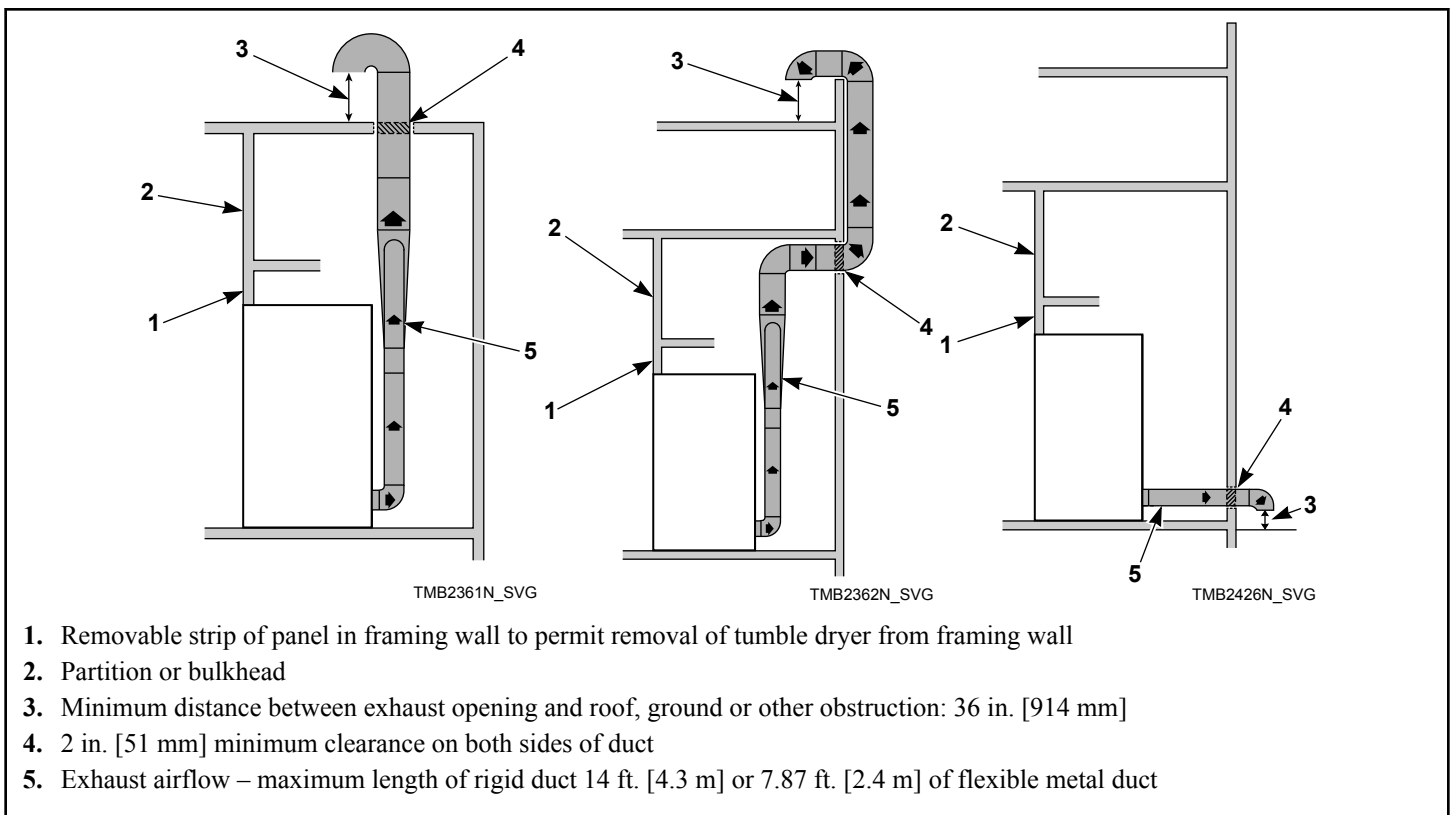

Figure 18

**NOTE: Do not install wire mesh or screen in exhaust duct opening to avoid lint build-up or impacting proper discharge of air from tumble dryers.**

**NOTE: Where exhaust duct pierces a combustible wall or ceiling, the opening must be sized per local codes.**

**NOTE: Inside of duct must be smooth. Do not use sheet metal screws to join sections.**

**NOTE: Locate exhaust far enough away from make-up air location to prevent re-introduction.**

Consult your local building code for regulations which may also apply.

**Individual Venting**

For maximum efficiency and performance, it is preferred to exhaust tumble dryer(s) individually to the outdoors.

**IMPORTANT: At no point may the cross sectional area of installed venting be less than the cross sectional area of the exhaust outlet of the tumble dryer.**

The exhaust duct must be designed so the static back pressure measured 12 inches [305 mm] from the exhaust outlet does not exceed the maximum allowable pressure specified in the Specifications and Dimensions Table or on the installation sticker on the rear of the tumble dryer.

**NOTE: Static back pressure must be measured with the tumble dryer running.**

The maximum allowable length venting is 14 feet [4.3 m] and two 90° elbows or equivalent. If the equivalent length of a duct required for an installation exceeds the maximum allowable equivalent length, the diameter of a round duct must be increased by 10% for each additional 20 feet [6.1 m]. Cross section area of a rectangular duct must be increased by 20% for each additional 20 feet [6.1 m]. Refer to *Table 3* to determine equivalent venting.

Duct Diameter	Equivalent Length of Rigid Straight Duct
8 in. [203 mm]	One 90° elbow = 9.3 ft. [2.8 m]
10 in. [254 mm]	One 90° elbow = 11.6 ft. [3.5 m]
12 in. [305 mm]	One 90° elbow = 14 ft. [4.3 m]
14 in. [356 mm]	One 90° elbow = 16 ft. [4.9 m]

Table 3 continues...

Duct Diameter	Equivalent Length of Rigid Straight Duct
16 in. [406 mm]	One 90° elbow = 18.7 ft. [5.7 m]
18 in. [457 mm]	One 90° elbow = 21 ft. [6.4 m]
Equivalent Length (meter) = 1.17 x Duct Diameter (mm)	

Table 3

Example: A 12 inch [305 mm] diameter duct’s equivalent length of 14 feet [4.3 m] of duct and two 90° elbows is:

Equivalent Length

= 14 ft. [4.3 m] + (2) 90° elbows

= 14 ft. [4.3 m] + 14 ft. [4.3 m] + 14 ft. [4.3 m]

= 42 ft. [12.8 m]

With the tumble dryer in operation, airflow at any point in the duct should be at least 1200 feet/min. [366 m/min.] to ensure that lint remains airborne. If 1200 feet/min. [366 m/min.] cannot be maintained, schedule monthly inspections and cleaning of the ductwork.

**NOTE: The maximum length of a flexible metal duct must not exceed 7.9 ft. [2.4 m] as required to meet UL2158, clause 7.3.2A.**

**Manifold Venting**

While it is preferable to exhaust tumble dryers individually to the outdoors, a main collector duct may be used if it is sized according to *Figure 20* and *Figure 21*. This illustration indicates minimum diameters, and should be increased if the collector length

exceeds 14 feet [4.3 m] and two 90° elbows. The diameter of a round duct must be increased by 10% for each additional 20 feet [6.1 m]. Cross sectional area of a rectangular or square duct must be increased 20% for each additional 20 feet [6.1 m]. Refer to *Table 4* to determine equivalent ducting sizing. The collector duct may be rectangular or square in cross section, as long as the area is not reduced. Provisions **MUST** be made for lint removal and cleaning of the collector duct.

The vent collector system must be designed so the static back pressure measured 12 inches [305 mm] from the exhaust outlet does not exceed the maximum allowable pressure specified in the Specifications and Dimensions Table or on the installation sticker on the rear of tumble dryer. Static back pressure must be measured with all tumble dryers vented into the collector operating.

**NOTE: Never connect a tumble dryer duct at a 90° angle to the collector duct. Refer to *Figure 19*. Doing so will cause excessive back pressure, resulting in poor performance. Never connect two tumble dryer exhaust ducts directly across from each other at the point of entry to the collector duct.**

With the tumble dryer in operation, airflow at any point in the duct should be at least 1200 feet/min. [366 m/min.] to ensure that lint remains airborne. If 1200 feet/min. [366 m/min.] cannot be maintained, schedule monthly inspections and cleaning of the ductwork.

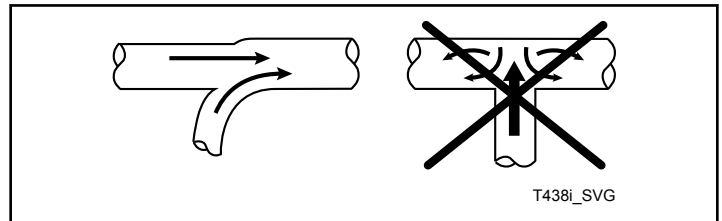

Figure 19



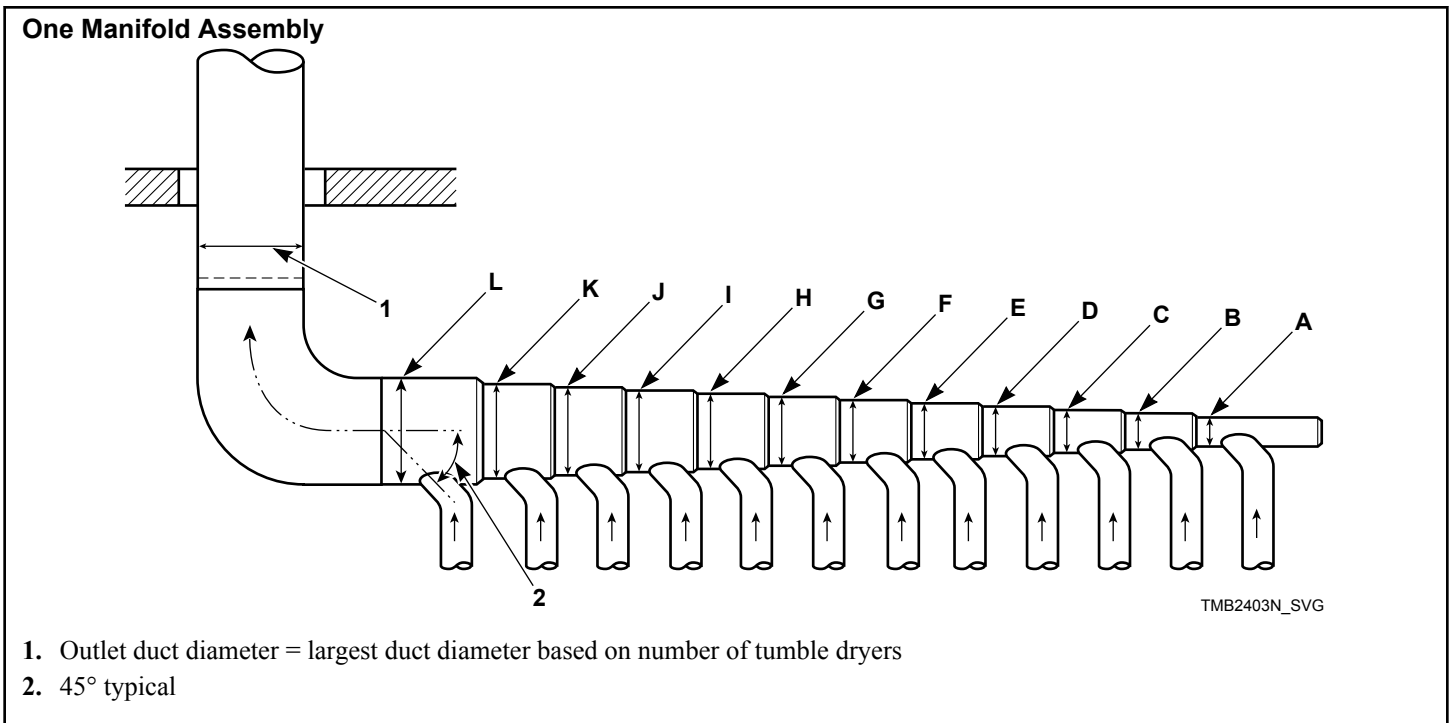

Figure 20

Duct Station	Eco Line 025	Standard Line 025, Eco T30 and all 030 Series	035, 055 and Standard T30 Series	T45 Series
A	4 in. [102 mm]	6 in. [152 mm]	8 in. [203 mm]	10 in. [254 mm]
B	6 in. [152 mm]	10 in. [254 mm]	12 in. [305 mm]	15 in. [381 mm]
C	8 in. [203 mm]	12 in. [305 mm]	15 in. [381 mm]	18 in. [457 mm]
D	10 in. [254 mm]	14 in. [356 mm]	17 in. [432 mm]	21 in. [533 mm]
E	12 in. [305 mm]	16 in. [406 mm]	19 in. [483 mm]	24 in. [610 mm]
F	12 in. [305 mm]	18 in. [457 mm]	21 in. [533 mm]	26 in. [660 mm]
G	14 in. [356 mm]	19 in. [483 mm]	23 in. [584 mm]	28 in. [711 mm]
H	14 in. [356 mm]	20 in. [508 mm]	24 in. [610 mm]	30 in. [762 mm]
I	15 in. [381 mm]	22 in. [559 mm]	26 in. [660 mm]	32 in. [813 mm]
J	16 in. [406 mm]	23 in. [584 mm]	27 in. [686 mm]	33 in. [838 mm]
K	17 in. [432 mm]	24 in. [610 mm]	28 in. [711 mm]	35 in. [889 mm]
L	18 in. [457 mm]	25 in. [635 mm]	30 in. [762 mm]	36 in. [914 mm]

Table 4

**NOTE:** *Table 4* represents tumble dryers with the same vent size. If multiple vent sizes are used, consult a local HVAC specialist.

**NOTE:** Duct clean-out recommended every 6 feet [0.18 m].

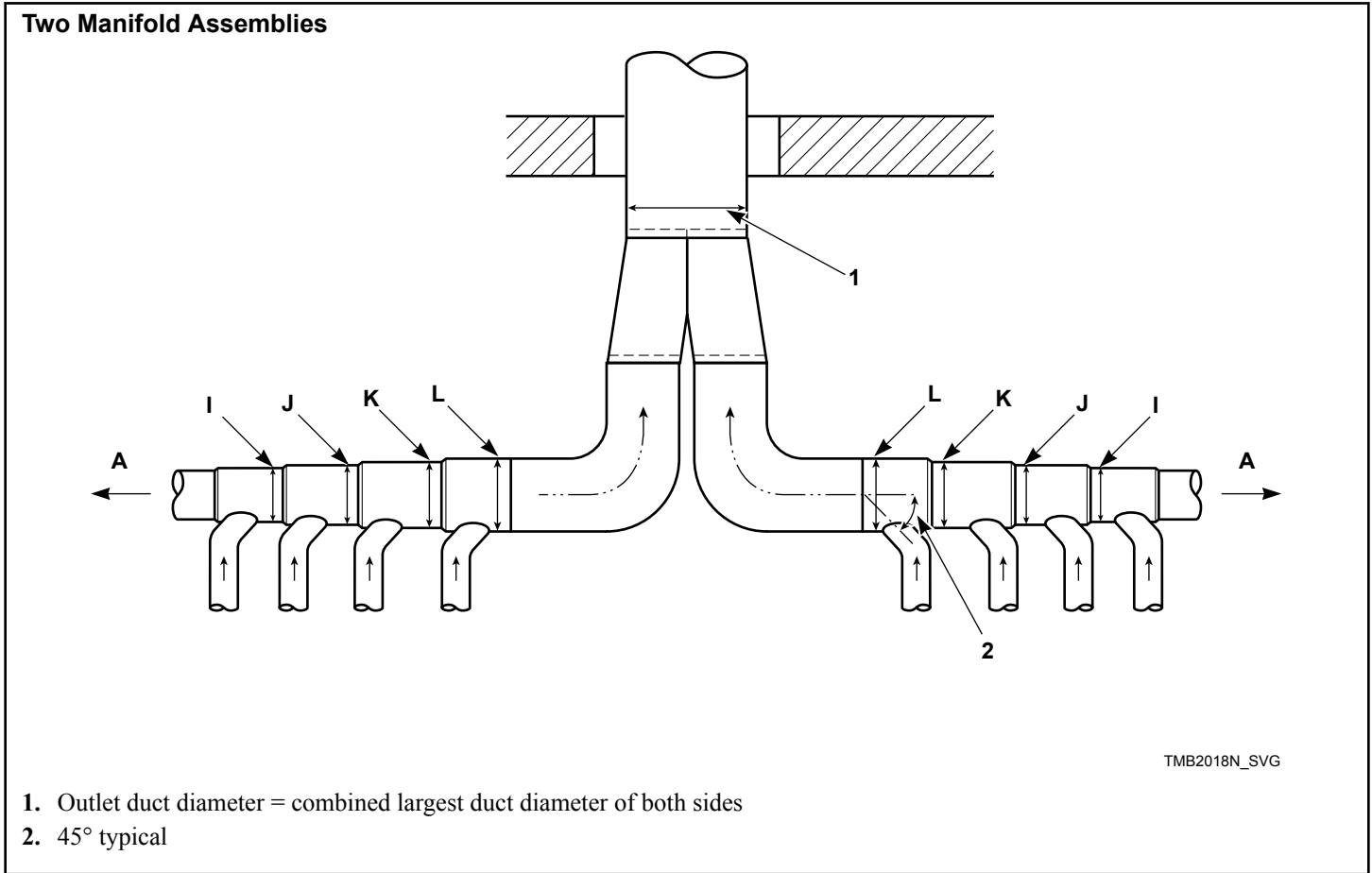



Figure 21

Refer to *Table 4* for measurements for each manifold.

# Gas Requirements

## Gas Requirements

	<b>WARNING</b>
<p>To reduce the risk of fire or explosion, <b>DO NOT CONNECT THE GAS LINE TO THE TUMBLE DRYER IF THE GAS SERVICE IS NOT THE SAME AS THAT SPECIFIED ON THE TUMBLE DRYER SERIAL PLATE!</b> It will first be necessary to convert the gas burner orifice and gas valve. Appropriate conversion kits are available.</p>	
W060R1	

	<b>WARNING</b>
<p>To reduce the risk of gas leaks, fire or explosion, use a new flexible stainless steel connector.</p>	
W774	

**IMPORTANT:** Any product revisions or conversions must be made by the Manufacturer’s Authorized Dealers, Distributors or local service personnel.

**IMPORTANT:** The tumble dryer must be isolated from the gas supply piping system by closing its individual manual shut-off valve during any pressure testing of the gas supply piping system at test pressure equal to or less than 0.5 psig [3.45 kPa, 34.5 mbar].

**NOTE:** For gas valves with a manual shut-off switch on the gas valve, the shut-off switch does not protect the valve from this pressure test. Use the individual manual shut-off valve from the gas supply piping system to protect the gas valve.

**IMPORTANT:** The tumble dryer and its manually operated appliance gas valve must be disconnected from the gas supply piping system during any pressure testing of that system at test pressures in excess of 0.5 psig [3.45 kPa, 34.5 mbar].

**IMPORTANT:** The installation must comply with local codes or, in the absence of local codes:

- with the latest edition of the “National Fuel Gas Code,” ANSI Z223.1/NFPA 54 in the U.S.A.
- with CAN/CSA-B149.1 Natural Gas and Propane Installation Code in Canada
- In Australia and New Zealand , installation must comply with the Gas Installations Standard AS/NZS 5601 Part 1: General Installations.

Obtain specific gas service pipe size from the gas supplier. Refer to *Table 5* and *Table 6* for general pipe size.

The following must be furnished and installed by the customer for the gas service line to each tumble dryer. Refer to *Figure 22* .

- Sediment traps
- Shut-off valves
- Supply pressure taps

It is important that equal pressure be maintained at all tumble dryer gas connections. This can be done by installing a 1 inch [25.4 mm] pipe gas loop to maintain equal pressure at all gas connections. Refer to *Figure 23* .

	<b>WARNING</b>
<p>To reduce the risk of fire or explosion, if the tumble dryer is to be connected to Liquefied Petroleum (L.P.) gas, a vent to the outdoors must be provided in the room where the tumble dryer is installed.</p>	
W062R1	

NATURAL GAS pressures with all gas appliances running (tumble dryers, water heaters, space heaters, furnace, etc.):

	Non-CE and Non-Australian Models	Australian and Korean Models	CE Models
Maximum	10.5 in. w.c.	2.61 kPa	26.1 mbar
Recommended	6.5 in. w.c	1.62 kPa	16.2 mbar
Minimum	5 in. w.c.	1.13 kPa	12.4 mbar

An in-line pressure regulator may be required if the line pressure exceeds 10.5 water column inches [26.1 mbar, 2.61 kPa] with all gas appliances running.

LIQUID PETROLEUM GAS (L.P.) pressures with all gas appliances running (tumble dryers, water heaters, space heaters, furnace, etc.):

	Non-CE and Non-Australian Models	Australian and Korean Models	CE Models
Maximum	13 in. w.c.	3.23 kPa	32.3 mbar

*Table continues...*

Gas Requirements

	<b>Non-CE and Non-Australian Models</b>	<b>Australian and Korean Models</b>	<b>CE Models</b>
Recommended	11 in. w.c.	2.74 kPa	27.4 mbar
Minimum	10 in. w.c.	2.49 kPa	24.9 mbar

For converting Non-CE models from Natural Gas to L.P. Gas:

025 Series	M6699P3
030 Series	M4703P3
T30 Series	M4707P3
035 Series	M4711P3
T45 Series	M4880P3
055 Series	M4924P3

CE GASES refer to Installing CE Gas Drying Tumble Dryers section, the above data does not apply to the CE.

Turn on gas and check all pipe connections (internal and external) for gas leaks with a non-corrosive leak detection fluid. Purge air in gas service line by operating the tumble dryers in the drying mode. If burner does not light and unit goes into lockout, open and close the door and restart. Repeat these steps until burner ignites. Use pipe compound, resistant to actions of L.P. gas, on all pipe threads.

	<b>WARNING</b>
<p><b>Check all pipe connections, internal and external, for gas leaks using a non-corrosive leak detection fluid. To reduce the risk of explosion or fire, DO NOT USE AN OPEN FLAME TO CHECK FOR GAS LEAKS! Gas connections should be checked twice a year for leakage.</b></p>	
W635	

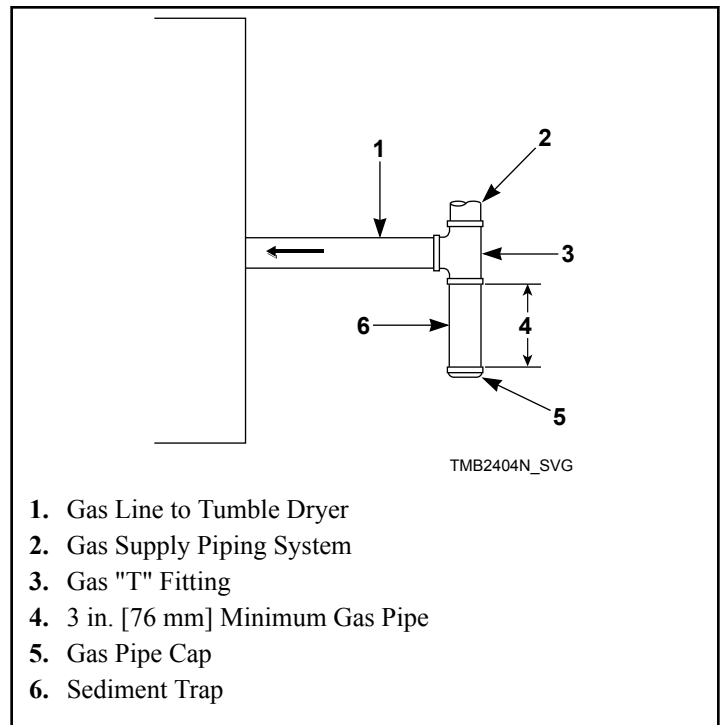

1. Gas Line to Tumble Dryer
2. Gas Supply Piping System
3. Gas "T" Fitting
4. 3 in. [76 mm] Minimum Gas Pipe
5. Gas Pipe Cap
6. Sediment Trap

Figure 22

## Gas Supply Pipe Sizing and Looping

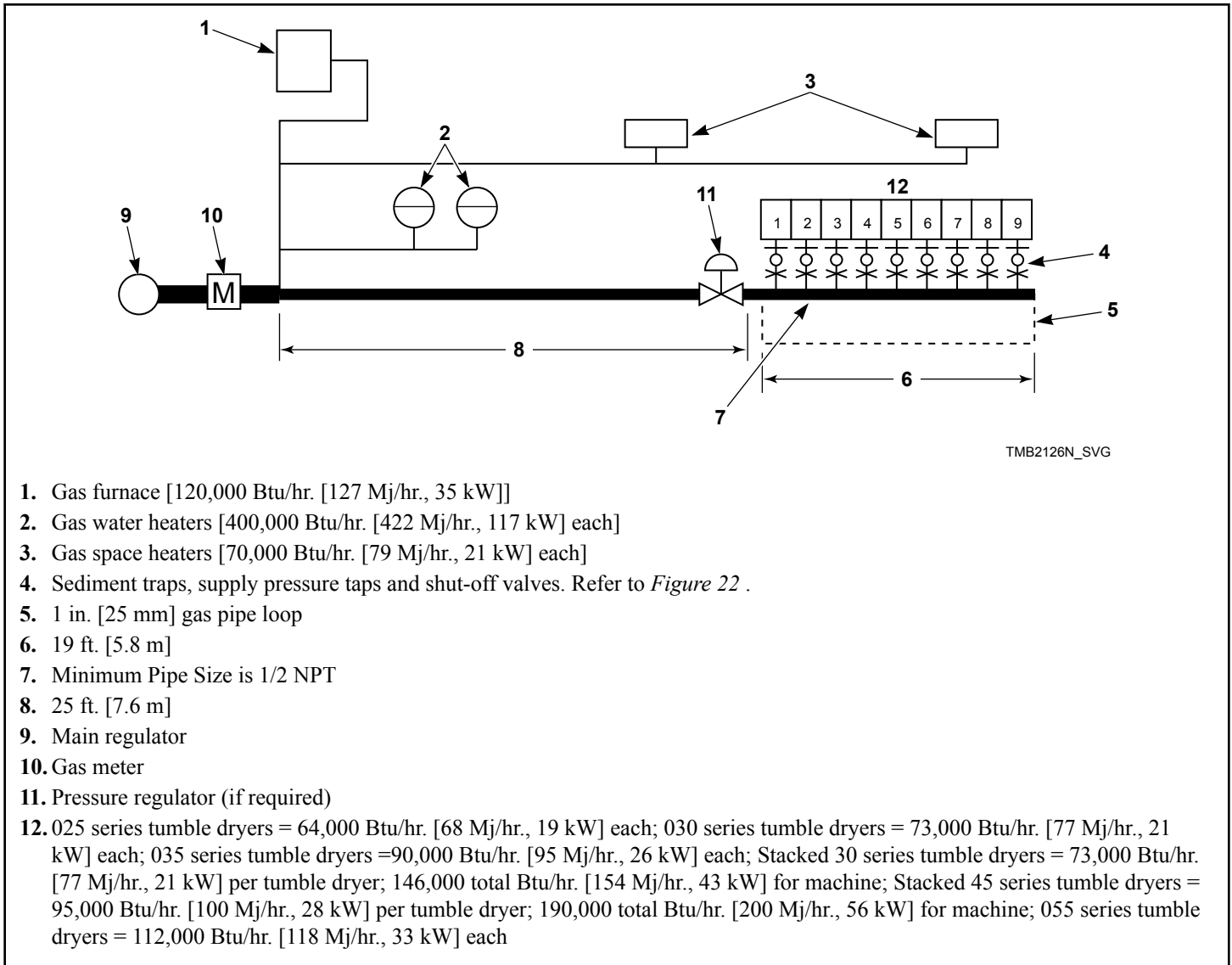

Figure 23

### SAMPLE CALCULATIONS:

Equivalent length = Total length of main gas supply pipe to the far end of the tumble dryers.

= 25 ft. + 19 ft. [7.6 m + 5.8 m] gas supply pipe

= 44 ft. [13.4 m] Total Gas Line

Total Btu/hr. = The sum of the Btu/hr. of all 030 series tumble dryers being fed by the main gas supply pipe.

= 9 x 73,000 [77, 21]

= 657,000 Btu/hr. [193 kW]

Using *Table 5*, the main supply pipe diameter should be 2 NPT.

**IMPORTANT: Gas loop piping must be installed as illustrated to equalize gas pressure for all tumble dryers connected to single gas service. Other gas using appliances should be connected upstream from loop.**

**Low Pressure Gas Pipe Sizes**

**NOTE: Sizing calculations based on National Fuel Gas Code.**

<b>Gas Pipe Size Required for 1000 BTU Natural Gas (Standard Conditions) at Upstream Pressure— 7.0 ± 1.5 inches water column pressure [17.4 ± 4.0 mbar, 1.74 ± 0.37 kPa]</b>						
<b>Gas Appli- ances Total BTU/hr.</b>	<b>Equivalent Length</b>					
	<b>25 feet [7.6 m]</b>	<b>50 feet [15.2 m]</b>	<b>75 feet [22.9 m]</b>	<b>100 feet [30 m]</b>	<b>125 feet [38 m]</b>	<b>150 feet [46 m]</b>
	<b>Based on 0.3 inches Water Column Pressure Drop for Length Given Sizes shown in Gas Pipe Nominal Size (NPT)</b>					
100,000	3/4	3/4	3/4	1	1	1
120,000	3/4	3/4	1	1	1	1
140,000	3/4	1	1	1	1	1
160,000	3/4	1	1	1	1-1/4	1-1/4
180,000	3/4	1	1	1-1/4	1-1/4	1-1/4
200,000	1	1	1	1-1/4	1-1/4	1-1/4
300,000	1	1-1/4	1-1/4	1-1/4	1-1/2	1-1/2
400,000	1-1/4	1-1/4	1-1/2	1-1/2	1-1/2	1-1/2
500,000	1-1/4	1-1/2	1-1/2	1-1/2	1-1/2	2
600,000	1-1/4	1-1/2	1-1/2	2	2	2
700,000	1-1/2	1-1/2	2	2	2	2
800,000	1-1/2	1-1/2	2	2	2	2
900,000	1-1/2	2	2	2	2	2-1/2
1,000,000	1-1/2	2	2	2	2-1/2	2-1/2
1,100,000	1-1/2	2	2	2	2-1/2	2-1/2
1,200,000	1-1/2	2	2	2-1/2	2-1/2	2-1/2
1,300,000	2	2	2-1/2	2-1/2	2-1/2	2-1/2
1,400,000	2	2	2-1/2	2-1/2	2-1/2	2-1/2
1,500,000	2	2	2-1/2	2-1/2	2-1/2	2-1/2
1,600,000	2	2	2-1/2	2-1/2	2-1/2	3

Table 5 *continues...*

<b>Gas Pipe Size Required for 1000 BTU Natural Gas (Standard Conditions) at Upstream Pressure— <math>7.0 \pm 1.5</math> inches water column pressure [<math>17.4 \pm 4.0</math> mbar, <math>1.74 \pm 0.37</math> kPa]</b>						
<b>Gas Appliances Total BTU/hr.</b>	<b>Equivalent Length</b>					
	<b>25 feet [7.6 m]</b>	<b>50 feet [15.2 m]</b>	<b>75 feet [22.9 m]</b>	<b>100 feet [30 m]</b>	<b>125 feet [38 m]</b>	<b>150 feet [46 m]</b>
	<b>Based on 0.3 inches Water Column Pressure Drop for Length Given Sizes shown in Gas Pipe Nominal Size (NPT)</b>					
1,700,000	2	2-1/2	2-1/2	2-1/2	3	3
1,800,000	2	2-1/2	2-1/2	2-1/2	3	3
1,900,000	2	2-1/2	2-1/2	3	3	3
2,000,000	2	2-1/2	2-1/2	3	3	3
2,200,000	2	2-1/2	3	3	3	3
2,400,000	2-1/2	2-1/2	3	3	3	3-1/2
2,600,000	2-1/2	2-1/2	3	3	3-1/2	3-1/2
2,800,000	2-1/2	3	3	3	3-1/2	3-1/2
3,000,000	2-1/2	3	3	3-1/2	3-1/2	3-1/2
For L.P. Gas, correct the total Btu/hr by multiplying it by 0.6. The answer is the equivalent Btu on the above chart.						

Table 5

### High Pressure Gas Pipe Sizes

**NOTE:** Sizing calculations based on National Fuel Gas Code.

**IMPORTANT:** A high pressure regulator is required at each machine.

Gas Pipe Size Required for 1000 BTU Natural Gas (Standard Conditions) at Upstream Pressure — 2.0 ± 0.4 PSI [138 ± 28 mbar, 13.7 ± 2.7 kPa]						
Gas Appliances Total BTU/hr.	Equivalent Length					
	25 feet [7.6 m]	50 feet [15.2 m]	75 feet [22.9 m]	100 feet [30 m]	125 feet [38 m]	150 feet [46 m]
	Based on 1 PSI Pressure Drop for Length Given Sizes shown in Gas Pipe Nominal Size (NPT)					
100,000	1/2	1/2	1/2	1/2	1/2	1/2
120,000	1/2	1/2	1/2	1/2	1/2	1/2
140,000	1/2	1/2	1/2	1/2	1/2	1/2
160,000	1/2	1/2	1/2	1/2	1/2	1/2
180,000	1/2	1/2	1/2	1/2	1/2	1/2
200,000	1/2	1/2	1/2	1/2	1/2	1/2
300,000	1/2	1/2	1/2	1/2	1/2	3/4
400,000	1/2	1/2	1/2	1/2	1/2	3/4
500,000	1/2	1/2	1/2	3/4	3/4	3/4
600,000	1/2	1/2	3/4	3/4	3/4	3/4
700,000	1/2	3/4	3/4	3/4	3/4	1
800,000	1/2	3/4	3/4	3/4	3/4	1
900,000	1/2	3/4	3/4	3/4	3/4	1
1,000,000	3/4	3/4	3/4	3/4	1	1
1,100,000	3/4	3/4	3/4	3/4	1	1
1,200,000	3/4	3/4	3/4	1	1	1
1,300,000	3/4	3/4	3/4	1	1	1-1/4
1,400,000	3/4	3/4	1	1	1	1-1/2
1,500,000	3/4	3/4	1	1	1	1-1/4
1,600,000	3/4	3/4	1	1	1	1-1/4

Table 6 continues...



<b>Gas Pipe Size Required for 1000 BTU Natural Gas (Standard Conditions) at Upstream Pressure — 2.0 ± 0.4 PSI [138 ± 28 mbar, 13.7 ± 2.7 kPa]</b>						
<b>Gas Appliances Total BTU/hr.</b>	<b>Equivalent Length</b>					
	<b>25 feet [7.6 m]</b>	<b>50 feet [15.2 m]</b>	<b>75 feet [22.9 m]</b>	<b>100 feet [30 m]</b>	<b>125 feet [38 m]</b>	<b>150 feet [46 m]</b>
	<b>Based on 1 PSI Pressure Drop for Length Given Sizes shown in Gas Pipe Nominal Size (NPT)</b>					
1,700,000	3/4	1	1	1	1	1-1/4
1,800,000	3/4	1	1	1	1	1-1/4
1,900,000	3/4	1	1	1	1	1-1/4
2,000,000	3/4	1	1	1	1-1/4	1-1/4
2,200,000	3/4	1	1	1-1/4	1-1/4	1-1/4
2,400,000	1	1	1	1-1/4	1-1/4	1-1/2
2,600,000	1	1	1-1/4	1-1/4	1-1/4	1-1/2
2,800,000	1	1	1-1/4	1-1/4	1-1/4	1-1/2
3,000,000	1	1	1-1/4	1-1/4	1-1/4	1-1/2

For L.P. Gas, correct the total Btu/hr by multiplying it by 0.6. The answer is the equivalent Btu on the above chart.

Table 6

## High Altitude Burner Orifice Sizing

For CE models, consult local gas supplier.

For proper operation at altitudes above 2,000 feet [610 m], the gas burner orifice size must be reduced to ensure complete combustion. Refer to *Table 7* or *Table 8*.

## Standard Line Models

Model	Gas	Altitude	Burner Orifice				New Rate
		feet [meters]	No.	inches [mm]	Quantity	Part No.	Btu/hr.* [Mj/hr.]
025 Series	Natural Gas	2,001-4,000 [610-1,220]	26	0.1470 [3.7]	1	M401000	58,880 [62.12]
		4,001-6,000 [1,221-1,830]	27	0.1440 [3.7]		M400998	53,760 [56.72]
		6,001-8,000 [1,831-2,440]	28	0.1405 [3.6]		M401014	48,640 [51.32]
		8,001-10,000 [2,441-3,050]	29	0.1360 [3.4]		M400997	43,520 [45.91]
	L.P. Gas	2,001-6,000 [610-1,830]	43	0.0890 [2.3]		M406184	58,880 [62.12]
		6,001-8,000 [1,831-2,440]	44	0.0860 [2.2]		M401011	48,640 [51.32]
		8,001-10,000 [2,441-3,050]	46	0.0810 [2.1]		M401003	43,520 [45.91]
030 Series	Natural Gas	2,001-4,000 [610-1,220]	22	0.1570 [4.0]	1	M402996	67,160 [70.85]
		4,001-6,000 [1,221-1,830]	24	0.1520 [3.9]		M402980	61,320 [64.69]
		6,001-8,000 [1,831-2,440]	26	0.1470 [3.7]		M401000	55,480 [58.53]
		8,001-10,000 [2,441-3,050]	28	0.1405 [3.6]		M401014	49,640 [52.37]
	L.P. Gas	2,001-6,000 [610-1,830]	42	0.0935 [2.4]		M403017	67,160 [70.85]
		6,001-8,000 [1,831-2,440]	43	0.0890 [2.3]		M406184	55,480 [58.53]
		8,001-10,000 [2,441-3,050]	44	0.0860 [2.2]		M401011	49,640 [52.37]

Table 7 continues...

Model	Gas	Altitude	Burner Orifice				New Rate
		feet [meters]	No.	inches [mm]	Quantity	Part No.	Btu/hr.* [Mj/hr.]
T30 Series	Natural Gas	2,001-4,000 [ 610-1,220]	22	0.1570 [4.0]	2	M402996	134,320 [141.71]
		4,001-6,000 [ 1,221-1,830]	24	0.1520 [3.9]		M402980	122,640 [129.39]
		6,001-8,000 [ 1,831-2,440]	26	0.1470 [3.7]		M401000	110,960 [117.06]
		8,001-10,000 [ 2441-3,050]	28	0.1405 [3.6]		M401014	99,280 [104.74]
	L.P. Gas	2,001-6,000 [ 610-1,830]	42	0.0935 [2.4]		M403017	134,320 [141.71]
		6,001-8,000 [ 1,831-2,440]	43	0.0890 [2.3]		M406184	110,960 [117.06]
		8,001-10,000 [ 2,441-3,050]	44	0.0860 [2.2]		M401011	99,280 [104.74]
035 Series	Natural Gas	2,001-4,000 [ 610-1,220]	17	0.1730 [4.4]	1	M411374	82,800 [87.35]
		4,001-6,000 [ 1,221-1,830]	18	0.1695 [4.3]		M402988	75,600 [79.76]
		6,001-8,000 [ 1,831-2,440]	20	0.1610 [4.1]		M401002	68,400 [72.16]
		8,001-10,000 [ 2,441-3,050]	22	0.1570 [4.0]		M402996	61,200 [64.57]
	L.P. Gas	2,001-4,000 [ 610-1,220]	38	0.1015 [2.6]		M411376	82,800 [87.35]
		4001-6000 [1,221-1,830]	39	0.0955 [2.5]		M401007	75,600 [79.76]
		6,001-8,000 [ 1,831-2440]	41	0.0960 [2.4]		M401015	68,400 [72.16]
		8,001-10,000 [ 2,441-3,050]	42	0.0935 [2.4]		M403017	61,200 [64.57]

Table 7 continues...

Model	Gas	Altitude	Burner Orifice				New Rate
		feet [meters]	No.	inches [mm]	Quantity	Part No.	Btu/hr.* [Mj/hr.]
T45 Series	Natural Gas	2,001-4,000 [610-1,220]	15	0.1800 [4.6]	2	M411511	183,000 [193.07]
		4,001-6,000 [1,221-1,830]	17	0.1730 [4.4]		M411374	168,400 [177.66]
		6,001-8,000 [1,831-2,440]	18	0.1695 [4.3]		M402988	155,000 [163.53]
		8,001-10,000 [2,441-3,050]	20	0.1610 [4.1]		M401002	142,600 [150.44]
	L.P. Gas	2,001-4,000 [610-1,220]	36	0.1065 [2.7]		M402487	183,000 [193.07]
		4,001-6,000 [1,221-1,830]	37	0.1040 [2.6]		M411375	168,400 [177.66]
		6,001-8,000 [1,831-2,440]	38	0.1015 [2.6]		M411376	155,000 [163.53]
		8,001-10,000 [2,441-3,050]	40	0.0980 [2.5]		M406361	142,600 [150.44]
055 Series	Natural Gas	2,001-4,000 [610-1,220]	10	0.1929 [4.9]	1	M402994	104,360 [110.1]
		4,001-6,000 [1,221-1,830]	12	0.1890 [4.8]		M411372	99,562 [105.04]
		6,001-8,000 [1,831-2,440]	14	0.1811 [4.6]		M411371	92,324 [97.4]
		8,001-10,000 [2,441-3,050]	16	0.1772 [4.5]		M411373	87,321 [92.12]
	L.P. Gas	2,001-4,000 [610-1,220]	32	0.1142 [2.9]		M402444	104,354 [110.09]
		4,001-6,000 [1,221-1,830]	33	0.1142 [2.9]		M401022	99,027 [104.47]
		6,001-8,000 [1,831-2,440]	35	0.1102 [2.8]		M402487	93,838 [97.94]
		8,001-10,000 [2,441-3,050]	36	0.1063 [2.7]		M411375	87,630 [92.45]

\*Btu/hr. derate of 4% per 1,000 feet [305 meters] of altitude.

Table 7

## Eco Line Models

Model	Gas	Altitude	Burner Orifice				New Rate
		feet [meters]	No.	inches [mm]	Quantity	Part No.	Btu/hr.* [Mj/hr.]
025 Series	Natural Gas 50 Hz	2,001-4,000 [610-1,220]	31	0.1200 [3.0]	1	M401017	43,200 [46]
		4,001-6,000 [1,221-1,830]	33	0.1130 [2.9]		M401022	37,800 [40]
		6,001-8,000 [1,831-2,440]	34	0.1110 [2.8]		M411512	34,200 [36]
		8,001-10,000 [2,441-3,050]	36	0.1065 [2.7]		M411375	30,600 [32]
	Natural Gas 60 Hz	2,001-4,000 [610-1,220]	30	0.1285 [---]		M401021	48,300 [51]
		4,001-6,000 [1,221-1,830]	1/8	0.1250 [3.2]		M402489	44,100 [47]
		6,001-8,000 [1,831-2,440]	31	0.1200 [3.0]		M401017	39,900 [42]
		8,001-10,000 [2,441-3,050]	33	0.1130 [2.9]		M401022	35,700 [38]
030 Series	Natural Gas 50 Hz	2,001-4,000 [610-1,220]	---	0.1299 [3.3]	1	44253801	48,300 [51]
		4,001-6,000 [1,221-1,830]	1/8	0.1250 [3.2]		M402489	44,100 [47]
		6,001-8,000 [1,831-2,440]	---	0.1220 [3.1]		70070903	39,900 [42]
		8,001-10,000 [2,441-3,050]	32	0.1160 [2.9]		M402444	35,700 [38]
	Natural Gas 60 Hz	2,001-4,000 [610-1,220]	---	0.1299 [3.3]		44253801	50,600 [53]
		4,001-6,000 [1,221-1,830]	1/8	0.1250 [3.2]		M402489	46,200 [49]
		6,001-8,000 [1,831-2,440]	---	0.1220 [3.1]		70070903	41,800 [44]
		8,001-10,000 [2,441-3,050]	31	0.1200 [3.0]		M401017	37,400 [39]

Table 8 continues...

Model	Gas	Altitude	Burner Orifice				New Rate
		feet [meters]	No.	inches [mm]	Quantity	Part No.	Btu/hr.* [Mj/hr.]
T30 Series	Natural Gas 50 Hz	2,001-4,000 [ 610-1,220]	1/8	0.1250 [3.2]	2	M402489	48,300 [51]
		4,001-6,000 [ 1,221-1,830]	---	0.1220 [3.1]		70070903	44,100 [47]
		6,001-8,000 [ 1,831-2,440]	31	0.1200 [3.0]		M401017	39,900 [42]
		8,001-10,000 [ 2441-3,050]	33	0.1130 [2.9]		M401022	35,700 [38]
	Natural Gas 60 Hz	2,001-4,000 [ 610-1,220]	---	0.1299 [3.3]		44253801	50,600 [53]
		4,001-6,000 [ 1,221-1,830]	1/8	0.1250 [3.2]		M402489	46,200 [49]
		6,001-8,000 [ 1,831-2,440]	---	0.1220 [3.1]		70070903	41,800 [44]
		8,001-10,000 [2,441-3,050]	32	0.1160 [2.9]		M402444	37,400 [39]
035 Series	Natural Gas 50 Hz	2,001-4,000 [ 610-1,220]	29	0.1360 [---]	1	M400997	50,600 [53]
		4,001-6,000 [ 1,221-1,830]	---	0.1339 [3.4]		44254001	46,200 [49]
		6,001-8,000 [ 1,831-2,440]	30	0.1285 [---]		M401021	41,800 [44]
		8,001-10,000 [ 2,441-3,050]	---	0.1220 [3.1]		70070903	37,400 [39]
	Natural Gas 60 Hz	2,001-4,000 [ 610-1,220]	28	0.1405 [3.6]		M401014	58,880 [62]
		4001-6000 [1,221-1,830]	---	0.1378 [3.5]		70476601	53,760 [57]
		6,001-8,000 [ 1,831-2440]	---	0.1339 [3.4]		44254001	48,640 [51]
		8,001-10,000 [ 2,441-3,050]	1/8	0.1250 [3.2]		M402489	43,520 [46]

Table 8 continues...

Model	Gas	Altitude	Burner Orifice				New Rate
		feet [meters]	No.	inches [mm]	Quantity	Part No.	Btu/hr.* [Mj/hr.]
T45 Series	Natural Gas 50 Hz	2,001-4,000 [ 610-1,220]	24	0.1520 [3.9]	2	M402980	68,080 [72]
		4,001-6,000 [ 1,221-1,830]	26	0.1470 [3.7]		M401000	62,160 [66]
		6,001-8,000 [ 1,831-2,440]	28	0.1405 [3.6]		M401014	56,240 [59]
		8,001-10,000 [ 2,441-3,050]	29	0.1360 [---]		M400997	50,320 [53]
	Natural Gas 60 Hz	2,001-4,000 [ 610-1,220]	21	0.1590 [4.0]		M402992	73,600 [78]
		4,001-6,000 [ 1,221-1,830]	23	0.1540 [3.9]		M401020	67,200 [71]
		6,001-8,000 [ 1,831-2,440]	26	0.1470 [3.7]		M401000	60,800 [64]
		8,001-10,000 [ 2,441-3,050]	28	0.1405 [3.6]		M401014	54,400 [57]
055 Series	Natural Gas 50 Hz	2,001-4,000 [ 610-1,220]	18	0.1695 [4.3]	1	M402988	82,800 [87]
		4,001-6,000 [ 1,221-1,830]	20	0.1610 [4.1]		M401002	75,600 [80]
		6,001-8,000 [ 1,831-2,440]	22	0.1570 [4.0]		M402996	68,400 [72]
		8,001-10,000 [ 2,441-3,050]	25	0.1495 [3.8]		M402997	61,200 [65]
	Natural Gas 60 Hz	2,001-4,000 [ 610-1,220]	14	0.1820 [4.6]		M411371	96,600 [102]
		4,001-6,000 [1,221-1,830]	16	0.1770 [4.5]		M411373	88,200 [93]
		6,001-8,000 [ 1,831-2,440]	18	0.1695 [4.3]		M402988	79,800 [84]
		8,001-10,000 [ 2,441-3,050]	20	0.1610 [4.1]		M401002	71,400 [75]

Table 8 continues...

Gas Requirements

Model	Gas	Altitude	Burner Orifice				New Rate
		feet [meters]	No.	inches [ mm]	Quan- tity	Part No.	Btu/hr.* [Mj/hr.]
<p>*Btu/hr. derate of 4% per 1,000 feet [305 meters] of altitude.</p> <p><b>NOTE: Eco line is only available in natural gas.</b></p>							

Table 8



# Electrical Requirements

## Electrical Requirements

	<b>WARNING</b>
<ul style="list-style-type: none"> <li>To reduce the risk of electric shock, disconnect this appliance from the power supply before attempting any user maintenance other than cleaning the lint trap for dryers. Turning the controls to the OFF position does not disconnect this appliance from the power supply.</li> <li>To reduce the risk of fire and electric shock, check with a qualified service person for proper grounding procedures. Improper connection of the equipment grounding conductor may result in a risk of electric shock.</li> <li>Certain internal parts are intentionally not grounded and may present a risk of electric shock only during servicing. Service Personnel - Do not contact the following parts while the appliance is energized: Input/Output Board and Variable Frequency Drive, including the heat sinks.</li> <li>This appliance shall be installed in accordance with the rules in force, and dryers used only in a sufficiently ventilated space. Consult technical instruction before installation and use of this appliance.</li> </ul>	
W935	

	<b>CAUTION</b>
<p>To reduce the risk of injury or component failure, if electrical supply is coming from a three phase service, DO NOT connect a "High Leg" or "Stinger Leg" to a single phase machine. On a three phase machine, if there is a "High Leg" or "Stinger Leg" it should be connected to L3.</p>	
W938	

	<b>WARNING</b>
<p>The appliance must not be supplied through an external switching device, such as a timer, or connected to a circuit that is regularly switched on and off by a utility.</p>	
W943	

**IMPORTANT:** Electrical connections must be made by a qualified electrician using data on serial plate, installation manuals and wiring diagram provided with tumble dryer and according to local codes. Install a circuit breaker as close to the tumble dryer as possible. If more than one tumble dryer is being installed, a circuit breaker must be provided for each.

**NOTE:** Connect tumble dryer to an individual branch circuit not shared with lighting or other equipment.

**NOTE:** 3 Phase Tumble Dryers Only - Do not use fuses to avoid the possibility of "single phasing" and causing premature failure of the motors.

	<b>WARNING</b>
<p>In case of servicing (or putting the tumble dryer out of order), disconnect the tumble dryer from the main supply by switching off the circuit breaker.</p>	
W796	

## Wiring Diagram

**NOTE:** Wiring diagram location: inside electrical box.

The wiring diagram part number is in the lower portion of the electrical data on the serial plate.

## Wiring for Central Pay

Applicable for the following control suffixes: 3K, 3L, BK, BL, KK, KL, LK, LL, WK and WL.

### System Connections

Connection to central pay systems will be made in the rear junction box of the tumble dryer. For stack models, connection for both the lower control and upper control will be made in the upper junction box.

Locate the harness with Black, Blue, Gray and Brown wires. The upper and lower harness can be identified by a yellow label on the harness tubing indicating "UPPER" and a white label on the harness tubing indicating "LOWER".

The wire colors will be the same regardless of control type. Splice the after-market central pay system wires to the tumble dryer control wire harness as follows.

Wire Colors	Description
BLK wire	24V AC/DC from central pay system

*Table continues...*

Wire Colors	Description
BLU wire	Common (negative) from central pay system
GRY wire	Machine busy signal to central pay system

Wire Colors	Description
BRN wire	Machine busy signal to central pay system

Table continues...

**Start Pulse Requirements**

All control types will consider a pulse valid if it is between 200 and 1000 milliseconds in length, with a minimum of 200 milliseconds between pulses.

**DX4 Control Only (3L or 3K Control Suffixes)**

The DX4 control tumble dryer comes configured to operate at 24 Volts AC or DC. If the central pay system provides 200-240V AC, conversion is possible. Loosen screw and move the BLK wire to the adjacent open terminal and tighten securely. Refer to *Figure 24* and *Figure 25*.

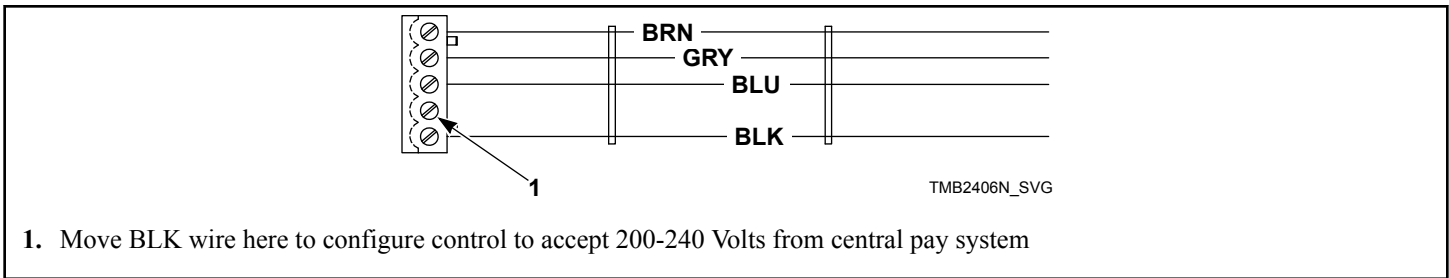

1. Move BLK wire here to configure control to accept 200-240 Volts from central pay system

Figure 24

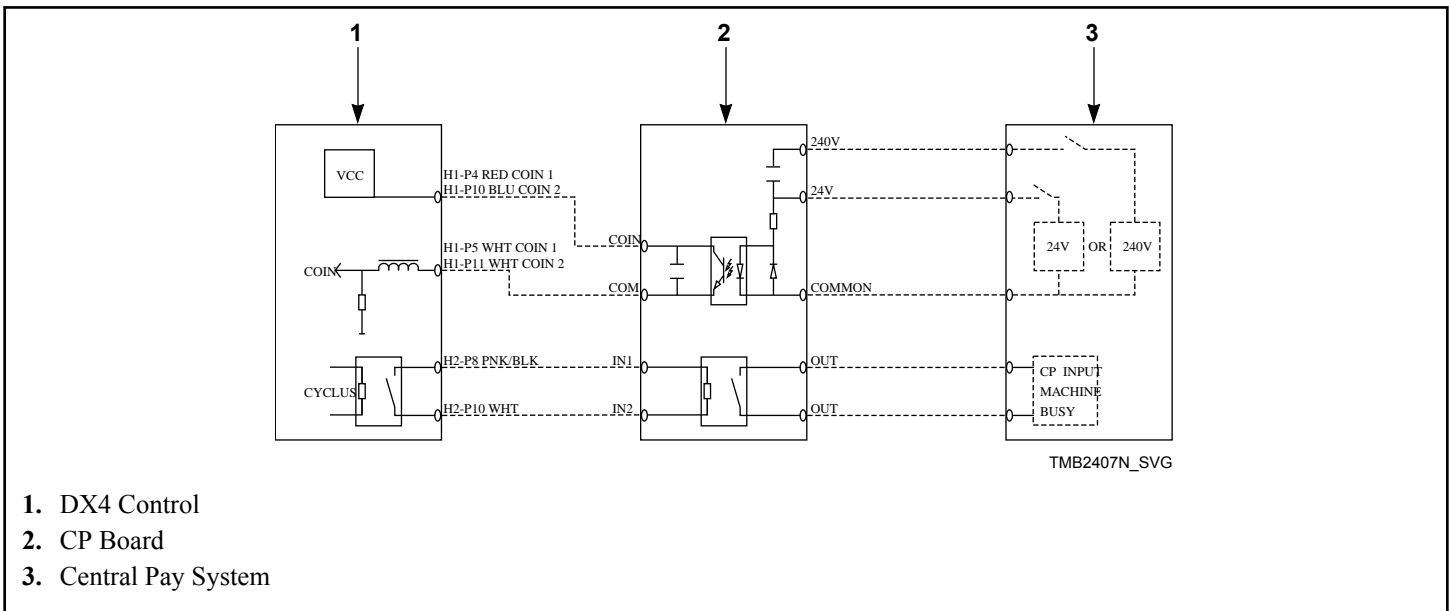

- 1. DX4 Control
- 2. CP Board
- 3. Central Pay System

Figure 25

## Grounding Instructions

**NOTE:** To ensure protection against shock, this tumble dryer **MUST** be electrically grounded in accordance with the local codes, or in the absence of local codes, with the latest edition of the National Electrical Code ANSI/NFPA No. 70. In Canada the electrical connections are to be made in accordance with CSA C22.1 latest edition Canadian Electrical Code, or local codes. Electrical work should be done by a qualified electrician.

This tumble dryer must be grounded. In the event of malfunction or breakdown, grounding will reduce the risk of electric shock by providing a path of least resistance for electric current. This tumble dryer must be connected to a grounded metal, permanent wiring system; or an equipment grounding conductor must be run with the circuit conductors and connected to the appropriate ground location.

- Metal conduit and/or BX cable is not considered ground.
- Connecting the Neutral from the electrical service box to the tumble dryer ground screw does not constitute a ground.
- A dedicated ground conduit (wire) must be connected between the electrical service box ground bar and tumble dryer ground screw.

	<b>WARNING</b>
<p>To reduce the risk of electrical shock, de-energize the electrical circuit being connected to the tumble dryer before making any electrical connections. All electrical connections should be made by a qualified electrician. Never attempt to connect a live circuit.</p>	
W409R1	

### Service/Ground Location



Models Through 7/9/12	Heat Source	Ground and Terminal Block Locations
Non-CE 025 030 035 055	Gas or Steam	Control Tray  <p style="text-align: right;">TMB2127N_SVG</p> <ol style="list-style-type: none"> <li>1. Ground Screw</li> <li>2. Terminal Block</li> </ol>

Table 9 continues...

	<b>CAUTION</b>
<p>Label all wires prior to disconnection when servicing controls. Wiring errors can cause improper and dangerous operation. Verify proper operation after servicing.</p>	
W071	

### For CE Models Only

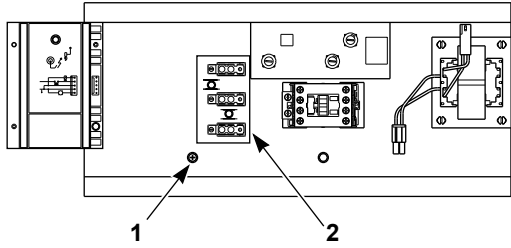
All OPL (non-vend) models are factory-equipped with an emergency stop button on the front panel. If the emergency stop function is desired on coin-operated models, an external emergency stop button may be installed.

**NOTE:** Activation of the emergency stop switch stops all machine control circuit functions, but **DOES NOT** remove all electrical power from machine.

Models Through 7/9/12	Heat Source	Ground and Terminal Block Locations
Non-CE 025 030 035 055 Series	Electric	Accessory Box (located below control tray) <b>NOTE: Do not make service connections in control tray.</b>  <p style="text-align: right;">TMB2128N_SVG</p> <ol style="list-style-type: none"> <li>1. Ground Lug</li> <li>2. Power Distribution Block</li> </ol>
CE 025 030 035 055	Gas or Steam	 <p style="text-align: right;">TMB2129N_SVG</p> <ol style="list-style-type: none"> <li>1. Models Through 7/31/11</li> <li>2. Ground Screw</li> <li>3. Terminal Block</li> </ol>

Table 9 continues...

Models Through 7/9/12	Heat Source	Ground and Terminal Block Locations
CE 025 030 035 055	Electric	 <p style="text-align: right;">TMB2130N_SVG</p> <ol style="list-style-type: none"> <li>1. Ground Lug</li> <li>2. Power Distribution Block</li> <li>3. Models Through 7/31/11</li> </ol>

Table 9

Models Starting 7/10/12	Ground and Terminal Block Locations
Non-CE 025 030 035 055	<p>Control Tray</p>  <p style="text-align: right;">TMB2377N_SVG</p> <ol style="list-style-type: none"> <li>1. Power Distribution Block</li> <li>2. Ground</li> </ol>
CE 025 030 035 055	<p>Control Tray</p>  <p style="text-align: right;">TMB2379N_SVG</p> <ol style="list-style-type: none"> <li>1. Power Distribution Block</li> <li>2. Ground</li> </ol>

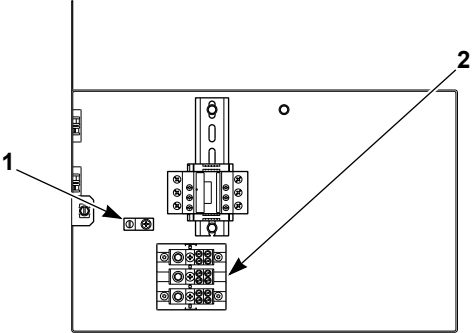
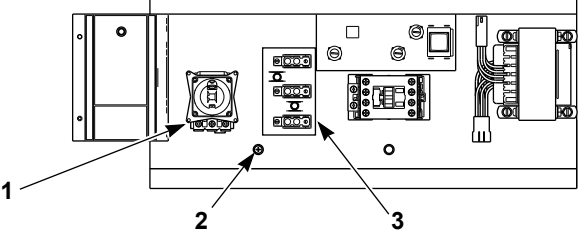
Table 10

Model	Heat Source	Ground and Terminal Block Locations
Non-CE T30/T45	T30: Gas or Steam T45: Gas	 <p style="text-align: right;">TMB2041N_SVG</p> <ol style="list-style-type: none"> <li>1. Power Distribution Block</li> <li>2. Ground</li> </ol>
Non-CE T30	Electric	 <p style="text-align: right;">TMB2113N_SVG</p> <ol style="list-style-type: none"> <li>1. Ground</li> <li>2. Power Distribution Block</li> </ol>
CE T30/T45	T30: Gas or Steam T45: Gas	 <p style="text-align: right;">TMB2114N_SVG</p> <ol style="list-style-type: none"> <li>1. Terminal Block</li> <li>2. Power Disconnect (Models Through 7/31/11)</li> <li>3. Ground Screw</li> </ol>

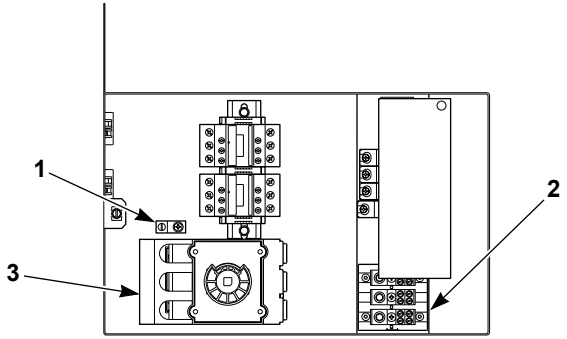
Table continues...

Model	Heat Source	Ground and Terminal Block Locations
CE T30	Electric	 <p style="text-align: right;">TMB2115N_SVG</p> <ol style="list-style-type: none"> <li>1. Ground Lug</li> <li>2. Power Disconnect (Models Through 7/31/11)</li> <li>3. Power Distribution Block</li> </ol>

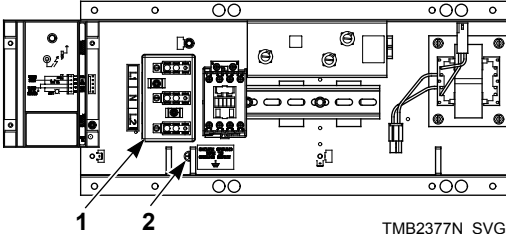
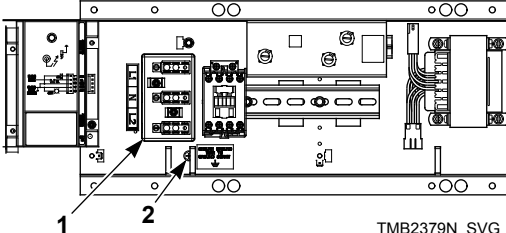
## To Connect Electrical Service To The Tumble Dryer

The following steps outline the procedure for connecting electrical service to the tumble dryer.

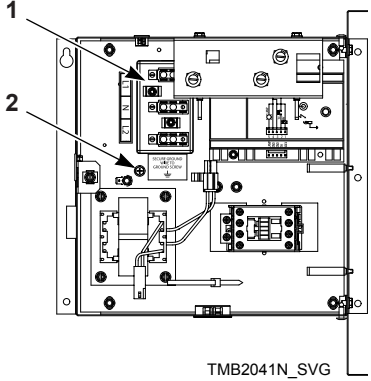
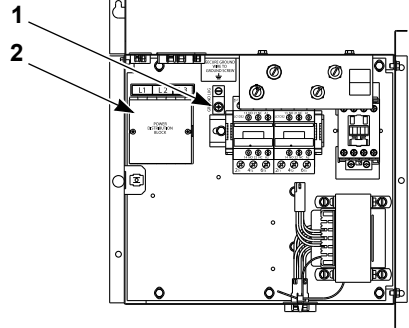
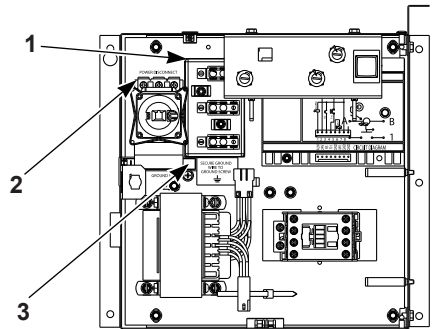
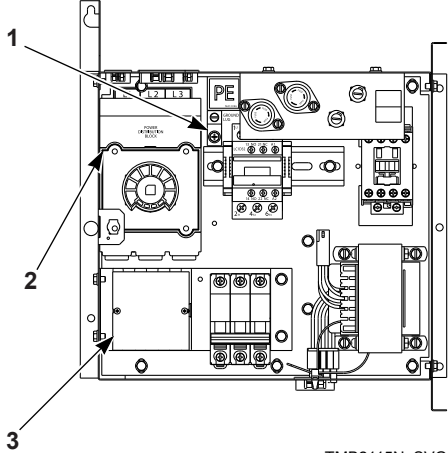
- 3 Phase Models – Each tumble dryer must be connected to its own individual branch circuit breaker, not fuses, to avoid the possibility of “single phasing” and causing premature failure of the motor(s).
- Electrical service must be connected using the appropriate permanent rigid metal conduit system.
- Service conductors must be copper only.

For an existing service, determine your service voltage and conductor amperage. Carefully review the tumble dryer serial plate ratings and Electrical Requirements section of this manual. If service is inadequate it must be upgraded by a qualified electrical contractor. Never connect an improper or inadequate service to any machine.

## Configuring Your Tumble Dryer for Other Service Voltages

Several gas and steam tumble dryer models have been designed to be field convertible to other service voltages. Refer to *Table 11* for these models:

Models	If your Serial Plate voltage is:	Your tumble dryer can be converted to the following voltages:
025, 030, 035, 055, T30	120 Volt/60 Hertz/1 Phase	208-240 Volt/60 Hertz/1 Phase
025, 030, 035, 055, T30	200-220 Volt/60 Hertz/1 Phase	100 Volt/60 Hertz/1 Phase
025, 030, 035, 055, T30	200 Volt/50 Hertz/1 Phase	100 Volt/50 Hertz/1 Phase
025, 030, 035, 055, T30, T45	240 Volt/60 Hertz/3 Phase	200-208 Volt/60 Hertz/3 Phase
025, 030, 035, 055, T30	380 Volt/50 Hertz/3 Phase	400-415 Volt/50 Hertz/3 Phase

Table 11

**NOTE: Electric models are not field convertible and must be connected to service specified on serial plate.**

If tumble dryer requires conversion for use on another service voltage, complete the steps detailed in the Conversion Instructions section prior to connecting service to machine.

## Electrical Requirements

If tumble dryer does not require conversion or has been converted according to the Conversion Instructions section of this manual, continue with step 1.

**NOTE: The wiring diagram is located inside the junction or contactor box.**

1. For new service, install a circuit breaker of proper voltage and current rating as close to each tumble dryer as possible.
2. Route service conduit from service breaker panel to tumble dryer service connection box. Conduit routing should not obstruct access for maintenance or servicing. Refer to Service/Ground Location.
3. Pull conductors through conduit and attach to circuit breaker and ground connection. Secure service ground wire to the grounding screw or lug. Attach service conductors to appropriately labeled positions on the terminal block. Make sure all connections are secure.
4. Complete ferrite installation instructions for all gas and steam models with OM control suffix.
5. Check electrical service phase sequence (3 Phase models only) as follows:

6. Energize the electrical service and momentarily start the tumble dryer. Check the direction of cylinder rotation. If the cylinder rotates clockwise as viewed from the front, the phase sequence is correct. If the cylinder rotates counterclockwise, proceed with step b.
7. Disconnect power to machine, disconnect and reverse the L1 and L2 connections on the terminal block.

## Electrical Connections for T30 and T45 Only

All gas and steam tumble dryers require a single service connection to TB1 of the upper unit junction box only. The serial plate reflects current draw, breaker/fuse size and conductor amperage required for the entire machine.

All electric tumble dryers require separate service connections for each upper and lower unit. Serial Plate ratings reflect current draw, breaker/fuse size and conductor amperage required per unit.



## Conversion Instructions

<p><b>If serial plate voltage is:</b></p>	<p><b>Tumble Dryer can be converted to the following voltages:</b></p>
<p><b>120 Volt/60 Hertz/1 Phase</b>  <b>2W&amp;G</b>  <b>(All models except T45)</b></p>	<p><b>208-240 Volt/60 Hertz/1 Phase Models:</b>  <b>3W&amp;G</b></p> <ol style="list-style-type: none"> <li>1. Prior to connecting service, locate the red or black with red stripe wire which runs between terminal block and the fan motor relay or contactor. Refer to figure below.</li> <li>2. Disconnect the red or black with red stripe wire from L1 of the terminal block and connect to L2 of the terminal block.</li> <li>3. Sign and date conversion sticker located on back of tumble dryer.</li> <li>4. Follow the instructions covered in Connecting Electrical Service section.</li> </ol> <div data-bbox="860 745 1518 1071" style="border: 1px solid black; padding: 10px;"> <p style="text-align: right; margin-right: 50px;">T381L_SVG</p> </div> <ol style="list-style-type: none"> <li>1. 120 V~ Location (as received)</li> <li>2. 208 or 240 V~ Location (as converted)</li> <li>3. To Fan Motor Relay or Contactor</li> <li>4. RED or BLK With Red Stripe</li> </ol> <p><b>NOTE: Motors operate on 120 Volt power regardless of input voltage configuration.</b></p>
<p><b>240 Volt/60 Hertz/3 Phase</b>  <b>3W&amp;G</b></p>	<p><b>200-208 Volt/60 Hertz/3 Phase Models:</b>  <b>3W&amp;G</b></p> <ol style="list-style-type: none"> <li>1. Prior to connecting electric service, locate transformer configuration jumper in junction box area.</li> <li>2. Remove the 240 Volt jumper and replace it with the 208 Volt jumper located in the literature packet in cylinder.</li> <li>3. Sign and date conversion sticker located on back of tumble dryer.</li> <li>4. Follow the instructions covered in Connecting Electrical Service section.</li> </ol>

*Table continues...*

<p><b>If serial plate voltage is:</b></p>	<p><b>Tumble Dryer can be converted to the following voltages:</b></p>
<p><b>200-220 Volt/60 Hertz/1 Phase</b>  <b>200 Volt/50 Hertz/1 Phase</b>  <b>2W&amp;G</b>  <b>(All models except T45)</b></p>	<p><b>100 Volt/60 Hertz/1 Phase INTERNATIONAL Models:</b>  <b>2W&amp;G</b>  <b>100 Volt/50 Hertz/1 Phase INTERNATIONAL Models:</b>  <b>2W&amp;G</b></p> <ol style="list-style-type: none"> <li>1. Prior to connecting electric service, locate transformer configuration jumper in junction box area.</li> <li>2. Remove the 208 Volt jumper and replace it with the 100 Volt jumper located in the literature packet from cylinder.</li> <li>3. Remove small access cover from back of the fan motor. Locate the two internal jumper wires, brown and blue connected to motor terminals #6 and #2. Move brown wire from terminal #6 to terminal #2 and blue wire from terminal #2 to terminal #4. Be careful not to confuse light blue motor harness wire with the dark blue internal jumper.</li> <li>4. Carefully check motor wire connections with wiring diagram and verify that the motors are configured for low voltage operation before replacing covers.</li> <li>5. Sign and date conversion sticker located on back of tumble dryer.</li> <li>6. Follow the instructions covered in Connecting Electrical Service section.</li> </ol>
<p><b>380 Volt/50 Hertz/3 Phase</b>  <b>3W&amp;G</b>  <b>(All models except T45)</b></p>	<p><b>400-415 Volt/50 Hertz/3 Phase Models:</b>  <b>3W&amp;G</b></p> <ol style="list-style-type: none"> <li>1. Prior to connecting electric service, locate transformer configuration jumper in junction box area.</li> <li>2. Remove the 380 Volt jumper and replace it with the 415 Volt jumper located in the literature packet from cylinder.</li> <li>3. Sign and date conversion sticker located on back of tumble dryer.</li> <li>4. Follow the instructions covered in Connecting Electrical Service section.</li> </ol>

## Ferrite Ring Installation (025, 030, 035 and 055 Series Only)

Gas and Steam Models with OM Control Suffix Only (Models Through 7/31/11)

The ferrite ring provided in the literature packet must be installed over the power leads during connection of electrical service. The ferrite protects the sensitive electronic controls from destructive electrical disturbances which may be present on power lines to the machine. Failure to properly install the ferrite ring may result in damage to the electronic controls and will void control warranty.

To install:

1. Immediately after connection of power leads and before applying power to machine, locate each of the incoming service leads including ground.
2. Snap the ferrite ring closed over all the service leads inside of the contactor box as shown. It is important that the ferrite ring

be installed inside the contactor box. Refer to *Figure 26*. Do not install the ferrite outside of the box or other area. Make sure that service leads are in the center of the ferrite before closing the ring so as not to pinch or damage leads.

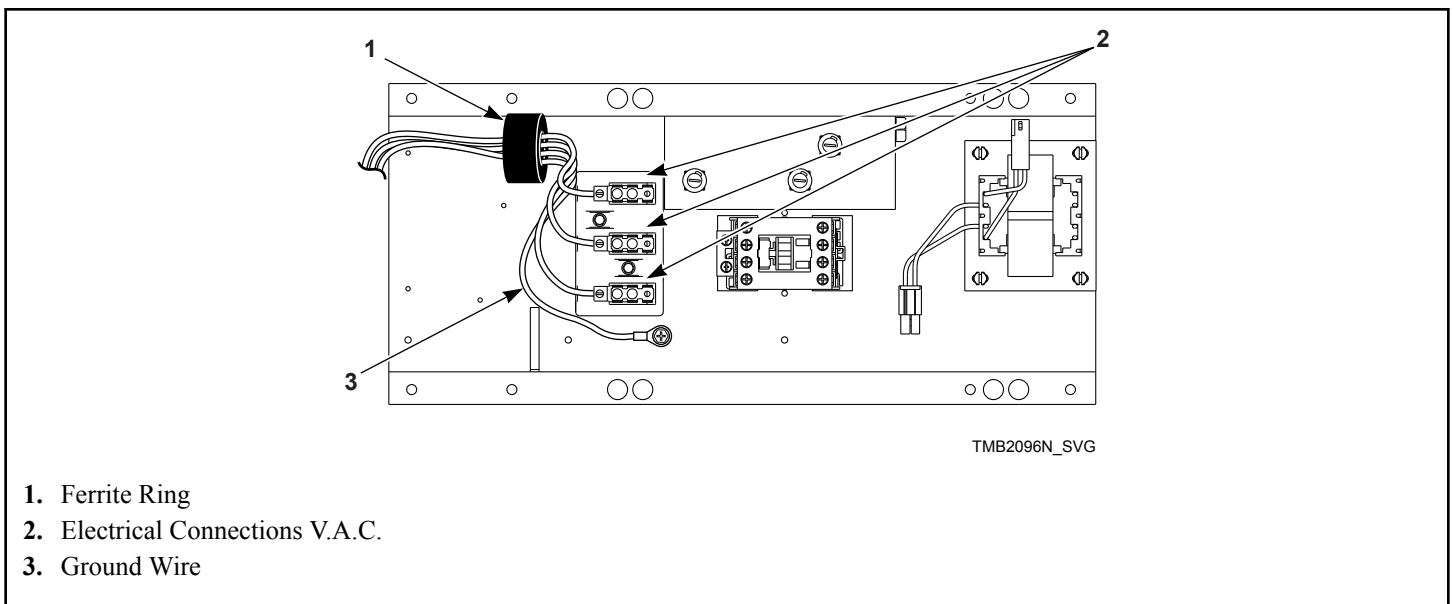

Figure 26

## Electrical Specifications

**NOTE:** Wire sizes were obtained from the Canadian Electrical Code for 75 C. wire and are intended for use as a guideline only. Electrical connections should be made by a qualified electrical contractor in accordance with all applicable local and national requirements.

**NOTE:** Electrical specifications below are subject to change without notice. Always refer to product serial plate for most current specifications of product being installed.

### 025, 030 and 035 Series Gas and Steam Models

Serial Plate Voltage	Terminal Block Connections Required	Serial Plate Amps		Recommended Circuit Breaker Rating	Wire Size AWG [mm <sup>2</sup> ]
		Nonreversing	Reversing		
120V/60Hz/1ph	L1, Neutral, and ground	12.0	N/A	15A	14 [2.5]
208-240V/60Hz/1ph	L1, L2, Neutral, and ground	6.7	N/A	10A	14 [2.5]
120V/60Hz/1ph	L1, Neutral, and ground	7.5**	N/A	10A	14 [2.5]
208-240V/60Hz/1ph	L1, L2, Neutral, and ground	4.5**	N/A	10A	14 [2.5]
100V/60Hz/1ph	L1, Neutral, and ground	11.0	N/A	15A	14 [2.5]

Table 12 continues...

Electrical Requirements

200-220V/ 60Hz/1ph	L1, Neutral, and ground	5.8	N/A	10A	14 [2.5]
100V/50Hz/1ph	L1, Neutral, and ground	12.1	N/A	20A	12 [4]
200V/50Hz/1ph	L1, Neutral, and ground	7.5	N/A	10A	14 [2.5]
230-240V/ 50Hz/1ph	L1, Neutral, and ground	7.5	N/A	10A	14 [2.5]
200-208V/ 60Hz/3ph	L1, L2, L3, and ground	3.2	4.0	10A*	14 [2.5]
240V/60Hz/3ph	L1, L2, L3, and ground	3.2	4.0	10A*	14 [2.5]
200V/50Hz/3ph	L1, L2, L3, and ground	2.9	3.5	10A*	14 [2.5]
230-240V/ 50Hz/3ph	L1, L2, L3, and ground	3.5	N/A	10A*	14 [2.5]
380V/50 or 60Hz/3ph	L1, L2, L3, and ground	1.5	2.0	10A*	14 [2.5]
400-415V/ 50Hz/3ph	L1, L2, L3, and ground	1.6	2.0	10A*	14 [2.5]
440V/60Hz/3ph	L1, L2, L3, and ground	1.6	N/A	10A*	14 [2.5]
460-480V/ 60Hz/3ph	L1, L2, L3, and ground	1.6	2.0	10A*	14 [2.5]
<p>* 3 Phase machines should not have fuses, breakers only.  ** Special low Amp blower model, 025 Series only.  N/A = Not Applicable</p>					

Table 12

**055 Series Gas Models**

Serial Plate Volt- age	Terminal Block Connections Re- quired	Serial Plate Amps		Recommended Circuit Breaker Rating	Wire Size AWG [mm <sup>2</sup> ]
		Nonreversing	Reversing		
120V/60Hz/1ph	L1, Neutral, and ground	9.2	N/A	15A	14 [2.5]

Table 13 *continues...*

208-240V/ 60Hz/1ph	L1, L2, Neutral, and ground	6.5	N/A	10A	14 [2.5]
100V/60Hz/1ph	L1, Neutral, and ground	9.8	N/A	15A	14 [2.5]
100V/50Hz/1ph	L1, Neutral, and ground	10	N/A	15A	14 [2.5]
200V/50Hz/1ph	L1, Neutral, and ground	6.2	N/A	15A	14 [2.5]
230-240V/ 50Hz/1ph	L1, Neutral, and ground	5.5	N/A	10A	14 [2.5]
200-208V/ 60Hz/3ph	L1, L2, L3, and ground	4.0	4.0	10A*	14 [2.5]
240V/60Hz/3ph	L1, L2, L3, and ground	4.0	4.5	10A*	14 [2.5]
380V/50Hz/3ph	L1, L2, L3, and ground	2.0	2.5	10A*	14 [2.5]
400-415V/ 50Hz/3ph	L1, L2, L3, and ground	2.0	2.5	10A*	14 [2.5]
* 3 Phase machines should not have fuses, breakers only. N/A = Not Applicable					

Table 13

**T30 Series Gas and Steam Models (Total Machine)**

Serial Plate Voltage	Terminal Block Con- nections Required	Serial Plate Amps	Recommended Circuit Breaker Rating	Wire Size AWG [mm <sup>2</sup> ]
120V/60Hz/1ph	L1, Neutral, and ground	16.0	20A	12 [4]
208-240V/60Hz/1ph	L1, L2, Neutral, and ground	8.0	15A	14 [2.5]
100V/60Hz/1ph	L1, Neutral, and ground	22.0	30A	10 [6]
200-220V/60Hz/1ph	L1, Neutral, and ground	11.6	15A	14 [2.5]
100V/50Hz/1ph	L1, Neutral, and ground	24.2	35A	8 [10]

Table 14 *continues...*

Electrical Requirements

200/50Hz/1ph	L1, Neutral, and ground	15.0	20A	12 [4]
230-240V/50Hz/1ph	L1, Neutral, and ground	9.0	15A	14 [2.5]
200-208V/60Hz/3ph	L1, L2, L3, and ground	6.4	10A*	14 [2.5]
240V/60Hz/3ph	L1, L2, L3, and ground	6.4	10A*	14 [2.5]
200V/50Hz/3ph	L1, L2, L3, and ground	5.8	10A*	14 [2.5]
230-240V/50Hz/3ph	L1, L2, L3, and ground	7.0	10A*	14 [2.5]
380V/50 or 60Hz/3ph	L1, L2, L3, and ground	3.0	10A*	14 [2.5]
400-415V/50Hz/3ph	L1, L2, L3, and ground	3.2	10A*	14 [2.5]
440V/60Hz/3ph	L1, L2, L3, and ground	3.3	10A*	14 [2.5]
460-480V/60Hz/3ph	L1, L2, L3, and ground	3.3	10A*	14 [2.5]

\* 3 Phase machines should not have fuses, breakers only.

Table 14

**T45 Series Gas Models (Total Machine)**

Serial Plate Voltage	Terminal Block Connections Required	Serial Plate Amps	Recommended Circuit Breaker Rating	Wire Size AWG [mm <sup>2</sup> ]
208-240V/60Hz/1ph	L1, L2, Neutral, and ground	12.0	15A	14 [2.5]
230V/50Hz/1ph	L1, Neutral and ground	10.2	15A	14 [2.5]
200V/50Hz or 60Hz/1ph	L1, Neutral and ground	11.2	15A	14 [2.5]
230-240V/50Hz/1ph	L1, Neutral and ground	10.8	15A	14 [2.5]
200-208V/60Hz/3ph	L1, L2, L3, and ground	9.6	15A*	14 [2.5]
240V/60Hz/3ph	L1, L2, L3, and ground	9.6	15A*	14 [2.5]

\* 3 Phase machines should not have fuses, breakers only.

Table 15

**9 kW Standard Line 025 Series Electric Models**

Serial Plate Voltage	Terminal Block Connections Required	Serial Plate Amps		Recommended Circuit Breaker Rating	Wire Size AWG [mm <sup>2</sup> ]
		Nonreversing	Reversing		
400V/50Hz/3ph	L1, L2, L3, and ground	16	N/A	20A*	12 [4]
* 3 Phase machines should not have fuses, breakers only. N/A = Not Applicable					

Table 16

**9 kW Eco Line 025 Series Electric Models**

Serial Plate Voltage	Terminal Block Connections Required	Serial Plate Amps		Recommended Circuit Breaker Rating	Wire Size AWG [mm <sup>2</sup> ]
		Nonreversing	Reversing		
200-208V/60Hz/3ph	L1, L2, L3, and ground	27.5	27.5	35A*	8 [10]
240V/60Hz/3ph	L1, L2, L3, and ground	24.4	24.4	35A*	8 [10]
380V/50Hz/3ph	L1, L2, L3, and ground	14.4	14.4	20A*	12 [4]
380V/60Hz/3ph	L1, L2, L3, and ground	14.6	14.6	20A*	12 [4]
400-415V/50Hz/3ph	L1, L2, L3, and ground	13.0	13.0	20A*	12 [4]
440V/60Hz/3ph	L1, L2, L3, and ground	12.9	12.9	20A*	12 [4]
460-480V/60Hz/3ph	L1, L2, L3, and ground	11.9	11.9	15A*	14 [2.5]
* 3 Phase machines should not have fuses, breakers only. N/A = Not Applicable					

Table 17

**12 kW 025 Series Electric Models**

Serial Plate Voltage	Terminal Block Connections Required	Serial Plate Amps		Recommended Circuit Breaker Rating	Wire Size AWG [mm <sup>2</sup> ]
		Nonreversing	Reversing		

Table 18 *continues...*

Electrical Requirements

208V/60Hz/1ph	L1, L2, Neutral, and ground	64	N/A	80A	4 [25]
240V/60Hz/1ph	L1, L2, Neutral, and ground	57	N/A	80A	4 [25]
200V/50Hz/1ph	L1, Neutral, and ground	63	N/A	80A	4 [25]
200V/60Hz/1ph	L1, L2 and ground	64	N/A	80A	4 [25]
230-240V/50Hz/1ph	L1, Neutral, and ground	58	N/A	80A	4 [25]
200-208V/60Hz/3ph	L1, L2, L3, and ground	37	37	50A*	6 [16]
200V/50Hz/3ph	L1, L2, L3, and ground	36	36	50A*	6 [16]
230-240V/50Hz/3ph	L1, L2, L3, and ground	33	N/A	50A*	6 [16]
240V/60Hz/3ph	L1, L2, L3, and ground	33	33	50A*	6 [16]
380V/50 or 60Hz/3ph	L1, L2, L3, and ground	20	20	25A*	10 [6]
400-415V/50Hz/3ph	L1, L2, L3, and ground	18	18	25A*	10 [6]
440V/60Hz/3ph	L1, L2, L3, and ground	17	17	25A*	10 [6]
460-480V/60Hz/3ph	L1, L2, L3, and ground	16	16	25A*	10 [6]
* 3 Phase machines should not have fuses, breakers only.					
N/A = Not Applicable					

Table 18

**21 kW Standard Line 030 Series Electric Models**

Serial Plate Voltage	Terminal Block Connections Required	Serial Plate Amps		Recommended Circuit Breaker Rating	Wire Size AWG [mm <sup>2</sup> ]
		Nonreversing	Reversing		
208V/60Hz/1ph	L1, L2, Neutral, and ground	108	N/A	150A	1/0 [50]

Table 19 continues...



240V/60Hz/1ph	L1, L2, Neutral, and ground	94	N/A	125A	1 [35]
200V/60Hz/1ph	L1, Neutral, and ground	108	N/A	150A	1/0 [50]
200V/50Hz/1ph	L1, Neutral, and ground	105	N/A	150A	1/0 [50]
230-240V/50Hz/1ph	L1, Neutral, and ground	95	N/A	125A	1 [35]
200-208V/60Hz/3ph**	L1, L2, L3, and ground	62	62	80A*	4 [25]
200V/50Hz/3ph**	L1, L2, L3, and ground	60	60	80A*	4 [25]
230-240V/50Hz/3ph**	L1, L2, L3, and ground	55	N/A	70A*	4 [25]
240V/60Hz/3ph**	L1, L2, L3, and ground	54	54	70A*	4 [25]
380V/50 or 60Hz/3ph**	L1, L2, L3, and ground	33	33	45A*	8 [10]
400-415V/50Hz/3ph**	L1, L2, L3, and ground	31	31	40A*	8 [10]
440V/60Hz/3ph	L1, L2, L3, and ground	29	N/A	40A*	8 [10]
460-480V/60Hz/3ph**	L1, L2, L3, and ground	27	27	35A*	8 [10]
<p>* 3 Phase machines should not have fuses, breakers only.</p> <p>** These serial plate voltages are only options available on the 30 series electric models.</p> <p>N/A = Not Applicable</p>					

Table 19

**12 kW Eco Line 030 Series Electric Models**

Serial Plate Voltage	Terminal Block Connections Required	Serial Plate Amps		Recommended Circuit Breaker Rating	Wire Size AWG [mm <sup>2</sup> ]
		Nonreversing	Reversing		
200-208V/60Hz/3ph**	L1, L2, L3, and ground	37.7	37.7	50A*	6 [16]

Table 20 continues...

Electrical Requirements

240V/60Hz/3ph**	L1, L2, L3, and ground	32.7	32.7	45A*	8 [10]
380V/50Hz/3ph**	L1, L2, L3, and ground	19.2	19.2	25A*	10 [6]
380V/60Hz/3ph**	L1, L2, L3, and ground	19.8	19.8	25A*	10 [6]
400-415V/50Hz/3ph**	L1, L2, L3, and ground	18.2	18.2	25A*	10 [6]
440V/60Hz/3ph**	L1, L2, L3, and ground	17.2	17.2	25A*	10 [6]
460-480V/60Hz/3ph**	L1, L2, L3, and ground	15.7	15.7	20A*	12 [4]
<p>* 3 Phase machines should not have fuses, breakers only.</p> <p>** These serial plate voltages are only options available on the 30 series electric models.</p>					

Table 20

**21 kW Standard Line T30 Series Electric Models**

Serial Plate Voltage	Terminal Block Connections Required	Serial Plate Amps	Recommended Circuit Breaker Rating	Wire Size AWG [mm <sup>2</sup> ]
200-208V/60Hz/3ph*	L1, L2, L3, and ground	62**	80A	4 [25]
200V/50Hz/3ph*	L1, L2, L3, and ground	60**	80A	4 [25]
230-240V/50Hz/3ph*	L1, L2, L3, and ground	55**	70A	4 [25]
240V/60Hz/3ph*	L1, L2, L3, and ground	54**	70A	4 [25]
380V/50 or 60Hz/3ph*	L1, L2, L3, and ground	33**	45A	8 [10]
400-415V/50Hz/3ph*	L1, L2, L3, and ground	31**	40A	8 [10]
440V/60Hz/3ph	L1, L2, L3, and ground	29**	40A	8 [10]
460-480V/60Hz/3ph	L1, L2, L3, and ground	27**	35A	8 [10]
<p>* These serial plate voltages are only options available on the T30 electric models. Current (Amp) is for one tumble dryer only.</p> <p>** Per tumble dryer on T30 electric models, each has two tumble dryers.</p>				

Table 21

**12 kW Eco Line T30 Series Electric Models**

Serial Plate Voltage	Terminal Block Connections Required	Serial Plate Amps	Recommended Circuit Breaker Rating	Wire Size AWG [mm <sup>2</sup> ]
200-208V/60Hz/3ph*	L1, L2, L3, and ground	37.3**	50A	6 [16]
240V/60Hz/3ph*	L1, L2, L3, and ground	32.7**	45A	8 [10]
380V/50Hz/3ph*	L1, L2, L3, and ground	19.5**	25A	10 [6]
380V/60Hz/3ph*	L1, L2, L3, and ground	19.5**	25A	10 [6]
400-415V/50Hz/3ph*	L1, L2, L3, and ground	17.5**	25A	10 [6]
440V/60Hz/3ph*	L1, L2, L3, and ground	17**	25A	10 [6]
460-480V/60Hz/3ph*	L1, L2, L3, and ground	15.5**	20A	12 [4]

\* These serial plate voltages are only options available on the T30 electric models. Current (Amp) is for one tumble dryer only.

\*\* Per tumble dryer on T30 electric models, each has two tumble dryers.

Table 22

**24 kW Standard Line 035 Series Electric Models**

Serial Plate Voltage	Terminal Block Connections Required	Serial Plate Amps		Recommended Circuit Breaker Rating	Wire Size AWG [mm <sup>2</sup> ]
		Nonreversing	Reversing		
208V/60Hz/1ph	L1, L2, Neutral, and ground	122	N/A	175A	2/0 [70]
240V/60Hz/1ph	L1, L2, Neutral, and ground	107	N/A	150A	1/0 [50]
200V/60Hz/1ph	L1, Neutral, and ground	122	N/A	175A	2/0 [70]
200V/50Hz/1ph	L1, Neutral, and ground	119	N/A	150A	1/0 [50]
230-240V/50Hz/1ph	L1, Neutral, and ground	108	N/A	150A	1/0 [50]
200-208V/60Hz/3ph	L1, L2, L3, and ground	71	71	90A*	3 [26.7]
200V/50Hz/3ph	L1, L2, L3, and ground	65	65	90A*	3 [26.7]
230-240V/50Hz/3ph	L1, L2, L3, and ground	62	N/A	80A*	4 [25]

Table 23 continues...

Electrical Requirements

240V/60Hz/3ph	L1, L2, L3, and ground	62	62	80A*	4 [25]
380V/50 or 60Hz/3ph	L1, L2, L3, and ground	38	38	50A*	6 [16]
400-415V/50Hz/3ph	L1, L2, L3, and ground	35	35	45A*	8 [10]
440V/60Hz/3ph	L1, L2, L3, and ground	33	N/A	45A*	8 [10]
460-480V/60Hz/3ph	L1, L2, L3, and ground	31	31	40A*	8 [10]
* 3 Phase machines should not have fuses, breakers only.					
N/A = Not Applicable					

Table 23

12 kW Eco Line 035 Series Electric Models

Serial Plate Voltage	Terminal Block Connections Required	Serial Plate Amps		Recommended Circuit Breaker Rating	Wire Size AWG [mm <sup>2</sup> ]
		Nonreversing	Reversing		
200-208V/60Hz/3ph	L1, L2, L3, and ground	36.4	36.4	50A*	6 [16]
240V/60Hz/3ph	L1, L2, L3, and ground	31.8	31.8	40A*	8 [10]
380V/50Hz/3ph	L1, L2, L3, and ground	19.7	19.7	25A*	10 [6]
380V/60Hz/3ph	L1, L2, L3, and ground	19.5	19.5	25A*	10 [6]
400-415V/50Hz/3ph	L1, L2, L3, and ground	17.9	17.9	25A*	10 [6]
440V/60Hz/3ph	L1, L2, L3, and ground	17.2	17.2	25A*	10 [6]
460-480V/60Hz/3ph	L1, L2, L3, and ground	16	16	20A*	12 [4]
* 3 Phase machines should not have fuses, breakers only.					

Table 24

**27 kW Standard Line 055 Series Electric Models**

Serial Plate Voltage	Terminal Block Connections Required	Serial Plate Amps		Recommended Circuit Breaker Rating	Wire Size AWG [mm <sup>2</sup> ]
		Nonreversing	Reversing		
208V/60Hz/1ph	L1, L2, Neutral, and ground	129	N/A	175A	2/0 [70]
240V/60Hz/1ph	L1, L2, Neutral, and ground	115	N/A	150A	1/0 [50]
200V/60Hz/1ph	L1, Neutral, and ground	122	N/A	175A	2/0 [70]
200V/50Hz/1ph	L1, Neutral, and ground	131	N/A	175A	2/0 [70]
230-240V/50Hz/1ph	L1, Neutral, and ground	119	N/A	150A	1/0 [50]
200-208V/60Hz/3ph	L1, L2, L3, and ground	79	79	100A*	3 [26.7]
240V/60Hz/3ph	L1, L2, L3, and ground	65	65	80A*	4 [25]
380V/50Hz/3ph	L1, L2, L3, and ground	43	43	60A*	6 [16]
400-415V/50Hz/3ph	L1, L2, L3, and ground	38	38	50A*	6 [16]
* 3 Phase machines should not have fuses, breakers only.					
N/A = Not Applicable					

Table 25

**18 kW Eco Line 055 Series Electric Models**

Serial Plate Voltage	Terminal Block Connections Required	Serial Plate Amps		Recommended Circuit Breaker Rating	Wire Size AWG [mm <sup>2</sup> ]
		Nonreversing	Reversing		
200-208V/60Hz/3ph	L1, L2, L3, and ground	52.9	52.9	70A*	4 [25]
240V/60Hz/3ph	L1, L2, L3, and ground	46.1	46.1	60A*	6 [16]
380V/50Hz/3ph	L1, L2, L3, and ground	28.6	28.6	40A*	6 [16]

Table 26 *continues...*

Electrical Requirements

400-415V/ 50Hz/3ph	L1, L2, L3, and ground	27.2	27.2	35A*	6 [16]
* 3 Phase machines should not have fuses, breakers only.					

Table 26

# Steam Requirements

## Steam Requirements



### WARNING

**This appliance does not contain inherent pressure relief. A pressure relief valve rated for a maximum of 125 psi shall be provided by the steam source.**

W942

**NOTE: Steam valve and required adapter are located in cylinder or lint compartment.**

**NOTE: Machines require a constant 80 to 100 psig [5.3 to 6.9 bar] steam service for optimum operation. The maximum allowable steam pressure is 125 psig [8.6 bar]. In no case may the pressure exceed the above value.**

Obtain specific steam service pipe sizes from steam system supplier or a qualified steam fitter.

- Refer to *Figure 27* for proper steam pipe configurations.
- To prevent condensate draining from headers to tumble dryer, piping should have a minimum 12 inch [300 mm] rise above respective header. Do not make steam connection to header with a horizontal or downward facing tee or elbow.
- Whenever possible, horizontal runs of steam lines must drain, by gravity, to respective steam header. Water pockets, or an improperly drained steam header will provide wet steam, causing improper operation of tumble dryer. If pockets or improper drainage cannot be eliminated, install a bypass trap to drain condensate from the low point in the steam header to the return.

- In both steam supply and steam return line, it is recommended that each have a pipe union and shut-off valve. This will enable you to disconnect the steam connections and service the tumble dryer while your laundry facility is in operation.
- Connect the steam solenoid valve to the related steam coil inlet connection with nipples, flex hoses, unions and tees.
- Strainers may require cleaning due to materials from hoses or pipes.
- Install vacuum breaker (optional), bucket trap with built-in strainer and check valve. For successful operation of tumble dryer, install trap 18 inches [460 mm] below coil and as near to the tumble dryer as possible. Inspect trap carefully for inlet and outlet markings and install according to trap manufacturer's instructions. If steam is gravity returned to boiler, omit trap but install vacuum breaker and check valve in return line near tumble dryer. Gravity return requires entire return plumbing be below steam coil outlets.
- Install union and shut-off valve in return line and make final pipe connections to return header.

**NOTE: To prevent water hammering, route return lines below outlets of steam coils.**

**NOTE: Steam inlet lines of each dryer should be trapped to keep line condensation from going into steam coils.**

**NOTE: IEC machines are shipped with BSPT adapters in the lint compartment. Not for stack machines.**

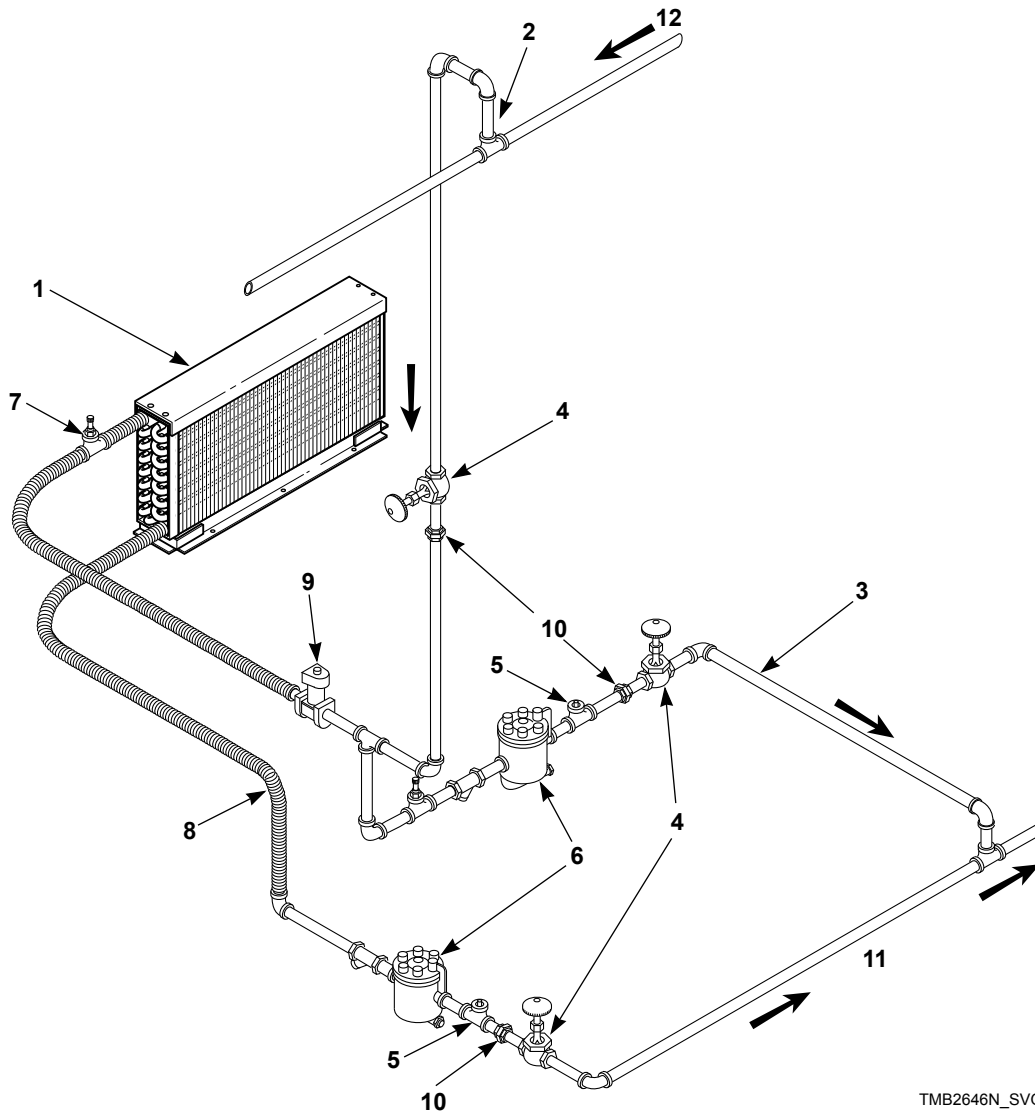

TMB2646N\_SVG

**NOTE: Refer to Table 27 for sizing of steam lines. Piping must also be sized accordingly for length of runs and number of elbows.**

- 1. Steam Coil
- 2. 12 in. [300 mm] Riser
- 3. Condensate Return Line from Supply Line
- 4. Shut-Off Valve
- 5. Check Valve
- 6. Trap with Built-In Strainer
- 7. Vacuum Breaker (Optional)
- 8. 18 in. [460 mm] Drop Recommended (not above outlet)
- 9. Solenoid Valve (Supplied with machine)
- 10. Union
- 11. Return
- 12. Supply

Figure 27



Model	Steam Pressure PSI [ bar]	Minimum Supply Pipe Diameter	Steam Trap Size* Pounds Condensate/ Hour [Kilograms Con- densate/Hour]
025/030 Series	80-100 [5.3-6.9]	3/4 NPT	134 [60.8]
035 Series	80-100 [5.3-6.9]	3/4 NPT	166 [75.3]
T30 Series	80-100 [5.3-6.9]	3/4 NPT	110 [49.9]

\* Based on 100 psi.

Table 27

## Piping Recommendations

- Trap each steam coil individually. Always keep the trap clean and in good working condition.
- When tumble dryer is on the end of a line of equipment, extend header at least 4 feet [1.2 m] beyond tumble dryer. Install shut-off valve, union, check valve and bypass trap at end of line. If gravity return to boiler, omit trap.
- Insulate steam supply and return lines for safety of operator and safety while servicing tumble dryer.

**IMPORTANT: Steam trap must be installed a minimum of 18 inches [460 mm] recommended below the steam coil outlet connections.**

4. Install a shut-off valve to each steam trap.
5. Connect to the condensate return lines.
6. For steam solenoid valve wiring connections, refer to Wiring Diagram supplied with tumble dryer.

	<b>WARNING</b>
<p><b>All system components must have a 125 psig [8.6 bar] working pressure. Shut-off valves must be installed upstream of the steam solenoid valve and downstream of each steam trap so components can be isolated for maintenance or emergency purposes. All components (solenoid valve, traps) must be supported to minimize loads on the tumble dryer steam coil connections.</b></p>	
W701R1	

## Installing Steam Trap and Making Condensate Return Connections

The steam trap must be installed and the coil outlet connections must be connected to the condensate return lines. The following steps outline the procedure for installing the steam trap and connecting the condensate return lines. Refer to *Figure 27* for typical installations.

1. Use flexible lines between steam inlet solenoid and steam coils, as well as outlet between steam coil and traps.
2. If necessary, install a strainer at the end of each flexible hose.
3. Install a steam trap to each strainer.

# Single Drop Timer

**NOTE: The following information is for models with an SD control suffix only.**

## Power-Up Mode

When power is applied to the tumble dryer, the IN USE light flashes factory status information. Following this, the control goes into READY Mode (light off) or RUN Mode if power was interrupted during a cycle (light on, time remaining unchanged). If a power disruption is less than 5 seconds, with a cycle in process, the control will enter Run Mode once power is restored and continue the cycle. If a power disruption is more than 5 seconds, with a cycle in process, the control will enter Start Mode once power is restored.

If the dry time dipswitch settings have not changed from the factory default, the IN USE LED will flash two to five times, depending on model.

## Ready Mode

In READY Mode (light off), the control waits for the vend to be satisfied. When vend is satisfied the control goes into START Mode.

## Start Mode

In START Mode (light on), the vend has been satisfied but the start button has not been pressed. Time remaining in the cycle will not change until the start button is pressed. When the start button is pressed the machine goes into RUN Mode.

## Run Mode

In RUN Mode (light on), the machine is running a cycle and the time remaining is counting down. When time remaining counts down to zero, the control goes into READY Mode.

## Door Open Mode

In Door Open Mode, the control turns off the heater and motor when the door is opened during a run cycle. The timer will continue to count down time and the IN USE LED is lit.

## End of Cycle Mode

In End of Cycle Mode, a cycle is complete and the IN USE LED is off. The control remains in this mode until the door is opened or additional vend has been satisfied.

## Setting Dry Time Dipswitches

To change the dry time on the tumble dryer, combinations of dipswitches can be set on the control.

There are eight dipswitches on the tumble dryer control. The first six switches are used to program the amount of additional heat time given for each coin pulse. The additional drying time is added to the factory default minimum heat time of one minute. A value of 1 to 64 minutes of additional drying time is available for each coin drop pulse.

### Models Through Serial No. 0908xxxxx

The last two switches are used to program the amount of additional cool down time. The additional cool down time is added to the factory default minimum cool down time of 1 minute. A value of 1 to 3 additional minutes is available. The control is shipped from the factory programmed with 1 minute of minimum heat time, preset with 7 additional minutes of drying time (dipswitches 1, 2 and 3 in ON position) and 1 minute of minimum cool down time for a total time of 9 minutes for a coin pulse.

### Models Starting Serial No. 0909xxxxx

The seventh switch is used to program the amount of additional cool down time. The additional cool down time is added to the factory default minimum cool down time of 1 minute. A value of 3 additional minutes is available. The control is shipped from the factory programmed with 1 minute of minimum heat time, preset with 7 additional minutes of drying time (dipswitches 1, 2 and 3 in ON position) and 1 minute of minimum cool down time for a total time of 9 minutes for a coin pulse.

The eight switch is used for the cycle reset. If the switch is OFF (default), the control will save the time left on a cycle in case of a power failure. If the switch is ON, the control will clear the cycle and go back to Ready Mode if there is a power failure.

The control reads the dipswitch settings at power-up. The control must be powered down to change the dipswitch settings.

To change the time for a coin pulse, the desired dry time dipswitches must be set to ON position. All other dipswitches must be in OFF position.

**NOTE: The control must be powered down for 10 seconds before the dipswitches can be changed.**

## Resetting Cycle Time to Zero

(Models Starting Serial No. 0909xxxxx)

To remove any cycle time that may have accumulated on the control during setup, the cycle time on the control can be reset to zero.

To reset the time, unplug the tumble dryer and set dipswitch 8 to ON position. Restore power to the tumble dryer for 10 seconds and once again unplug tumble dryer. Set dipswitch 8 to OFF position and restore power to the tumble dryer.

## Dipswitch Settings

Models Through Serial No. 0908xxxxx

Heat Time Per Coin Pulse (in minutes)	Heat Switch Number					
	1	2	3	4	5	6
1	OFF	OFF	OFF	OFF	OFF	OFF
2	ON	OFF	OFF	OFF	OFF	OFF
3	OFF	ON	OFF	OFF	OFF	OFF
4	ON	ON	OFF	OFF	OFF	OFF
5	OFF	OFF	ON	OFF	OFF	OFF
6	ON	OFF	ON	OFF	OFF	OFF
7	OFF	ON	ON	OFF	OFF	OFF
8 (factory default)	ON	ON	ON	OFF	OFF	OFF
9	OFF	OFF	OFF	ON	OFF	OFF
10	ON	OFF	OFF	ON	OFF	OFF
11	OFF	ON	OFF	ON	OFF	OFF
12	ON	ON	OFF	ON	OFF	OFF
13	OFF	OFF	ON	ON	OFF	OFF
14	ON	OFF	ON	ON	OFF	OFF
15	OFF	ON	ON	ON	OFF	OFF
16	ON	ON	ON	ON	OFF	OFF
17	OFF	OFF	OFF	OFF	ON	OFF
18	ON	OFF	OFF	OFF	ON	OFF
19	OFF	ON	OFF	OFF	ON	OFF
20	ON	ON	OFF	OFF	ON	OFF
21	OFF	OFF	ON	OFF	ON	OFF
22	ON	OFF	ON	OFF	ON	OFF
23	OFF	ON	ON	OFF	ON	OFF

*Table continues...*

## Single Drop Timer

Heat Time Per Coin Pulse (in minutes)	Heat Switch Number					
	1	2	3	4	5	6
24	ON	ON	ON	OFF	ON	OFF
25	OFF	OFF	OFF	ON	ON	OFF
26	ON	OFF	OFF	ON	ON	OFF
27	OFF	ON	OFF	ON	ON	OFF
28	ON	ON	OFF	ON	ON	OFF
29	OFF	OFF	ON	ON	ON	OFF
30	ON	OFF	ON	ON	ON	OFF
31	OFF	ON	ON	ON	ON	OFF
32	ON	ON	ON	ON	ON	OFF
33	OFF	OFF	OFF	OFF	OFF	ON
34	ON	OFF	OFF	OFF	OFF	ON
35	OFF	ON	OFF	OFF	OFF	ON
36	ON	ON	OFF	OFF	OFF	ON
37	OFF	OFF	ON	OFF	OFF	ON
38	ON	OFF	ON	OFF	OFF	ON
39	OFF	ON	ON	OFF	OFF	ON
40	ON	ON	ON	OFF	OFF	ON
41	OFF	OFF	OFF	ON	OFF	ON
42	ON	OFF	OFF	ON	OFF	ON
43	OFF	ON	OFF	ON	OFF	ON
44	ON	ON	OFF	ON	OFF	ON
45	OFF	OFF	ON	ON	OFF	ON
46	ON	OFF	ON	ON	OFF	ON
47	OFF	ON	ON	ON	OFF	ON
48	ON	ON	ON	ON	OFF	ON
49	OFF	OFF	OFF	OFF	ON	ON

*Table continues...*

Heat Time Per Coin Pulse (in minutes)	Heat Switch Number					
	1	2	3	4	5	6
50	ON	OFF	OFF	OFF	ON	ON
51	OFF	ON	OFF	OFF	ON	ON
52	ON	ON	OFF	OFF	ON	ON
53	OFF	OFF	ON	OFF	ON	ON
54	ON	OFF	ON	OFF	ON	ON
55	OFF	ON	ON	OFF	ON	ON
56	ON	ON	ON	OFF	ON	ON
57	OFF	OFF	OFF	ON	ON	ON
58	ON	OFF	OFF	ON	ON	ON
59	OFF	ON	OFF	ON	ON	ON
60	ON	ON	OFF	ON	ON	ON
61	OFF	OFF	ON	ON	ON	ON
62	ON	OFF	ON	ON	ON	ON
63	OFF	ON	ON	ON	ON	ON
64	ON	ON	ON	ON	ON	ON

Cool Down Per Cycle (in minutes)	Cool Down Switch Number	
	7	8
1 (factory default)	OFF	OFF
2	ON	OFF
3	OFF	ON

*Table continues...*

Cool Down Per Cycle (in minutes)	Cool Down Switch Number	
4	ON	ON

**Models Starting Serial No. 0909xxxxx**

Cool Down Per Cycle (in minutes)	Cool Down Switch Number	Cycle Reset Switch Number
	7	8
1 (factory default)	OFF	OFF ON
3	ON	

Total Cycle Time = Heat Time + Cool Down Time

### Topoffs

Any time the control receives a coin drop pulse during a cycle it will add the programmed dry time to the time currently remaining in the cycle. The maximum cycle time is 99 minutes, the control will not add time beyond 99 minutes. The cool down time will not change.

If the control receives a coin drop pulse during cool down the IN USE LED will flash briefly to indicate the coin input, the machine will exit cool down and it will start heating. The cycle time will be equal to the programmed dry time.

### Temperature Selector Switch

For five minutes after the control is powered up, there is a diagnostic feature that allows the temperature selector switches to be tested.

When the temperature selector is changed, the new setting is displayed by flashing the IN USE LED as follows:

High/Normal	4 flashes
-------------	-----------

*Table continues...*

### Error Codes

Display	Definition	Corrective Action
AF (flashing)	Airflow switch opened/closed 5 or more times in a running cycle.	Check airflow switch. Replace if inoperative.

Medium/PP	3 flashes
Low/Delicate	2 flashes
No Heat	1 flash

**NOTE: To change dipswitch settings refer to Dipswitch Settings section.**

### To Program a Short Test Cycle

1. Unplug machine power cord.
2. Write down machine control dip switch settings, then set them all to the off position. Refer to *Figure 28*.
3. Plug machine in and start a cycle.

**NOTE: With all control dip switches off, the total cycle time will be 2 minutes long (1 minute of heat and 1 minute of cool down).**

4. Once all testing is complete, unplug machine and re-set dip switches to their original settings.
5. Plug machine in.

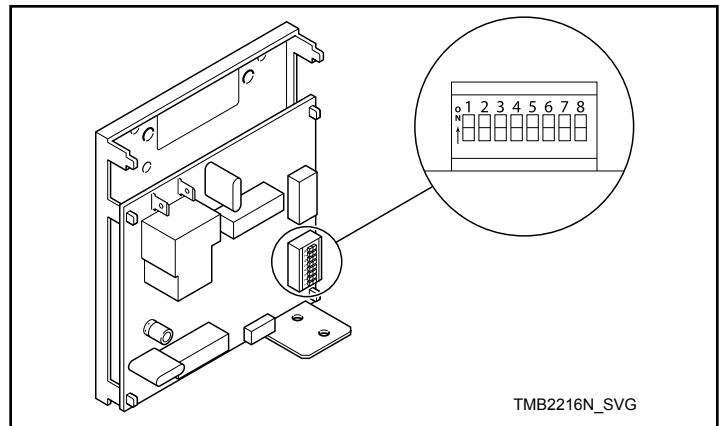



Figure 28

# Operating Instructions

## Operating Instructions

	<b>WARNING</b>
<p>To reduce the risk of fire:</p> <ul style="list-style-type: none"> <li>• <b>DO NOT DRY</b> articles containing foam rubber or similarly textured rubberlike materials.</li> <li>• <b>DO NOT DRY</b> plastics, anything containing wax or chemicals such as mops and cleaning cloths, or anything dry-cleaned at home with a dry-cleaning solvent.</li> <li>• <b>DO NOT TUMBLE</b> fiberglass curtains and draperies unless the label says it can be done. If they are dried, wipe out the cylinder with a damp cloth to remove particles of fiberglass.</li> </ul>	
W076	

	<b>WARNING</b>
<p>To reduce the risk of serious injury, allow cylinder to stop before cleaning lint screen.</p>	
W412	

## Emergency Stop Button On CE Models

All CE approved OPL tumble dryers are factory equipped with an emergency stop button located on the front panel. Refer to *Figure 29*.

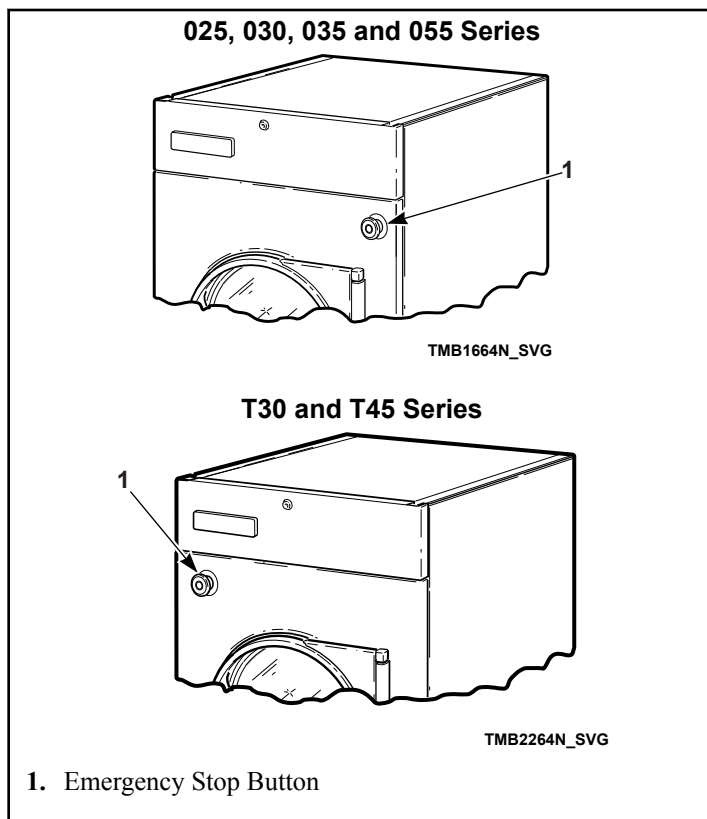



Figure 29

To operate emergency stop button:

- Press red emergency stop button to stop all action.
- To restart machine, pull red emergency stop button out and press START pad or button.

**NOTE: Activation of the emergency stop button stops all machine control circuit functions, but DOES NOT remove all electrical power from machine.**

## Operating Instructions

	<b>WARNING</b>
<p>To reduce the risk of fire, electric shock, or injury to persons, read the <b>IMPORTANT SAFETY INSTRUCTIONS</b> before operating this appliance.</p>	
W727	

**IMPORTANT: This appliance shall not be used to dry off solvents or dry cleaning fluids.**

1. Clean Lint Screen/Compartment
  - a. Remove any accumulated lint from the lint screen and compartment.

- b. Close panel tightly against tumble dryer frame and lock panel securely, if applicable.

**IMPORTANT: Clean lint screen and lint compartment daily. Failure to clean the lint screen daily will result in higher than normal temperatures that may damage laundry.**

	WARNING
<p><b>To reduce the risk of fire and risk of lint collecting in exhaust duct, do not operate tumbler without lint filter in place.</b></p>	
W772	

2. Load Laundry

- a. Open loading door and load cylinder with laundry. Maximum drying load is:

Model	Pound [Kg]
025	25 [11]
030	30 [13]
T30 (per cylinder)	30 [13]
035	35 [16]
T45 (per cylinder)	45 [20]
055	55 [24]

DO NOT OVERLOAD.

**NOTE: Overloading causes slow drying and wrinkling.**

- b. Close loading door. Tumble dryer will not operate with the door open.
3. Determine Control Type and Temperature Setting
- a. Refer to the various controls and follow the instructions for the appropriate control type.
  - b. The type of fabric being dried will determine the temperature setting. Consult the fabric care label or fabric manufacturer to determine proper temperature setting.

**IMPORTANT: Always follow the fabric care instructions supplied by the garment manufacturer.**

4. Remove Laundry

- a. When the cycle is complete, open door and remove the laundry.

## Reversing Operation

Tumble dryers with the reversing option prevent the tangling of large pieces of laundry and minimize wrinkling. These tumble dryers are equipped with a second motor and additional controls which reverse the rotation direction of the cylinder.

Some models may have a switch or touchpad in the control panel area so the operator can select the reversing or nonreversing operation. In nonreversing mode, the cylinder will always turn clockwise (as viewed from the front of the tumble dryer). If the cylinder is turning counterclockwise when switched to nonreversing, it will continue for a few seconds and then start up in the proper direction. Refer to Programming Manual for more information on reversing.

**IMPORTANT: Then set the reverse control switch to “nonreversing” and note that the cylinder turns constantly clockwise as viewed from the front of the tumble dryer. If not, interchange L1 and L2 service leads to the reverse drive motor.**

## Control Instructions

### Dual Digital Timer Control

QT and RQ Control Suffixes

1. Select HIGH, MED, LOW or NO HEAT by turning the temperature knob.
  - HIGH      Temperature 190°F [88°C]
  - MED        Temperature 170°F [ 77°C]
  - LOW        Temperature 120°F [49°C]

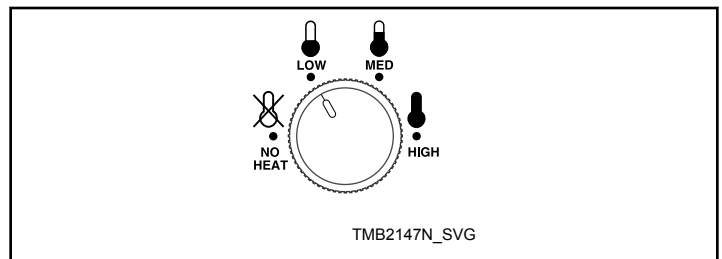

Figure 30

2. Set the HEAT TIME for the number of minutes (from 0 - 60) desired.

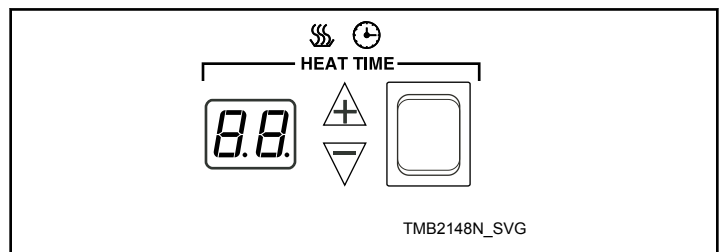

Figure 31



- Set the COOL DOWN TIME for the number of minutes (from 0 - 15) desired.

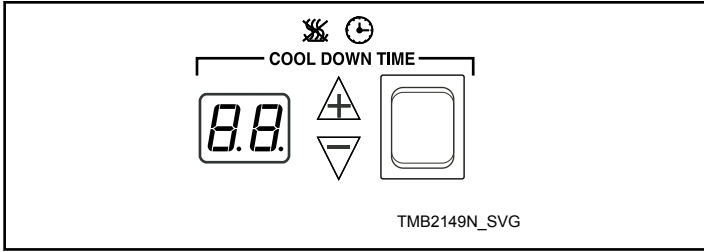

Figure 32

- Select reversing or nonreversing cylinder rotation setting, if applicable.

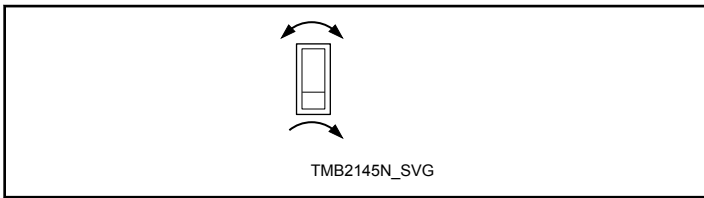

Figure 33

- Press and release START button to start tumble dryer. Display will show minutes remaining before end of cycle.

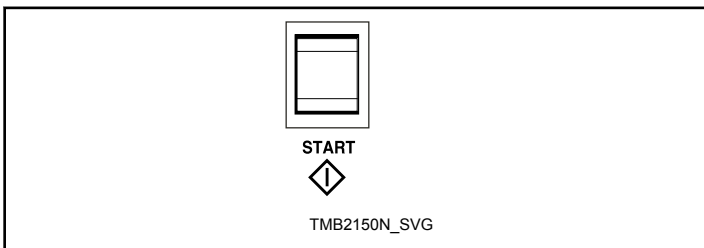

Figure 34

**NOTE: One touch drying is available for repetitive loads. If the START button is pressed while the machine is in Idle Mode, when the display is dark, the tumble dryer will repeat the last drying cycle. If the cycle time is adjusted before the cycle is started, the time displayed when the start button was pressed will be used for future cycles.**

**IMPORTANT: To stop the tumble dryer at any time during the cycle, OPEN DOOR. If the loading door or lint panel door is opened during the cycle, the heating system will shut off and the motor will stop. To restart the cycle, both doors must be closed and the START button must be pressed in.**

If the load cools to 90°F [32°C] before cool down time expires, the control will flash “Lr” (load ready) in the heat time display. If the door is not opened, the tumble dryer completes the selected cool down time. If the door is opened after reaching “Lr” temperature, the cycle will be terminated.

**NOTE: If display shows an error code, refer to Error Codes section.**

- When the cycle is complete, open door and remove the laundry.

	<b>WARNING</b>
<b>To prevent the risk of fire, remove laundry immediately in case of power failure.</b>	
W779	

**NOTE: This machine includes an anti-wrinkle/ extended tumble feature. After the drying cycle is complete, the cylinder will tumble without heat every few minutes. The intermittent tumbling will continue for one hour or until the door is opened. Anti-wrinkle feature will tumble the load without heat for 30 seconds every 2 minutes for 1 hour OR until the loading door is opened.**

Error Codes		
Display	Definition	Corrective Action
OP	Open thermistor error	<ul style="list-style-type: none"> <li>• Check thermistor. Replace if inoperative.</li> <li>• Check wiring diagram between control and thermistor. Refer to wiring diagram for proper wiring.</li> <li>• Check control. Replace if inoperative.</li> </ul>

Table 28 continues...

Error Codes		
Display	Definition	Corrective Action
SH	Shorted thermistor error	<ul style="list-style-type: none"> <li>• Check thermistor. Replace if inoperative.</li> <li>• Check wiring between control and thermistor. Refer to wiring diagram for proper wiring.</li> <li>• Check control. Replace if inoperative.</li> </ul>
AF - 1	Airflow switch closed when cycle started	<ul style="list-style-type: none"> <li>• Check airflow switch. Replace if inoperative.</li> </ul>
AF - 2	Airflow switch failed to close after cycle started	<ul style="list-style-type: none"> <li>• Check airflow switch. Replace if inoperative.</li> </ul>
AF (Flashing)	Bouncing Airflow Switch	<ul style="list-style-type: none"> <li>• Cycling power will not clear error. Start machine and allow it to terminate normally. To quickly advance cycle, set HEAT TIME to 0 and COOL DOWN TIME to 1, then press START (control may flash "Lr"). Once machine has cycled, identify and correct problem.</li> <li>• Check airflow switch to ensure that it is properly aligned and securely mounted in the mounting bracket.</li> <li>• Make sure airflow switch can open and close freely.</li> <li>• Check installation and make sure there is adequate airflow.</li> <li>• Make sure exhaust is not blocked.</li> <li>• Clean the lint screen.</li> <li>• Replace airflow switch if inoperative.</li> </ul>
AF (Solid)	Airflow Switch Closed when Resuming Cycle	<ul style="list-style-type: none"> <li>• Allow up to 20 seconds for this condition to clear.</li> <li>• Check if airflow switch opens at end of cycle.</li> <li>• Replace airflow switch if inoperative.</li> </ul>

Table 28

**Electronic OPL Micro Control**

OM Control Suffix

1. To use an Automatic Cycle, press an ON/SELECT pad. Select HIGH, MEDIUM, MED LOW, LOW or NO HEAT for items that should not be dried with heat. A light to the left of the selected pad lights up.

- HIGH temperature\* 185°F [85°C]
- HIGH temperature\*\* 190°F [88°C]
- MED temperature\* 160°F [ 71°C]
- MED temperature\*\* 165°F [ 74°C]
- MED LOW temperature\* 145°F [63°C]
- MED LOW temperature\*\* 155°F [68°C]
- LOW temperature (025-055) 120°F [49°C]

\* = (025, 030)  
 \*\* = (035, 055)

To use a Time Dry or Custom Cycle, refer to the Programming Manual.

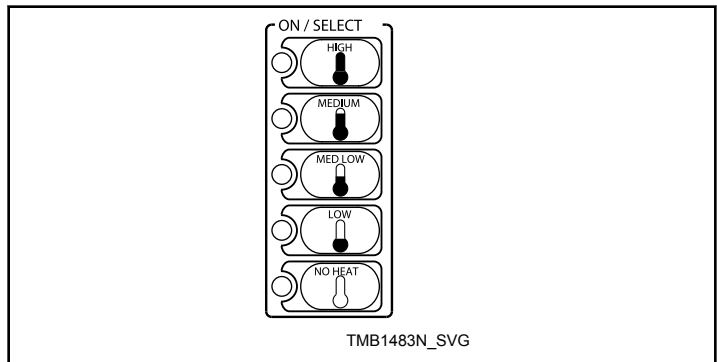

Figure 35

**NOTE: Do not press directly on lights or the center of pad. For proper selection, press on pad slightly to the right of center. Refer to Figure 36 .**

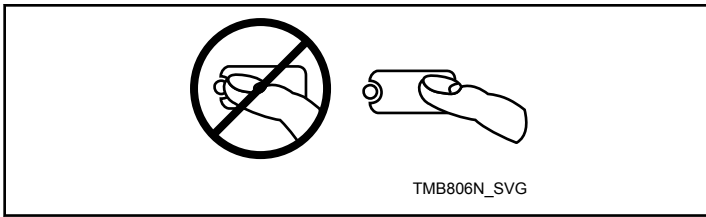

Figure 36

2. Select REVERSING or NONREVERSING cylinder rotation setting.

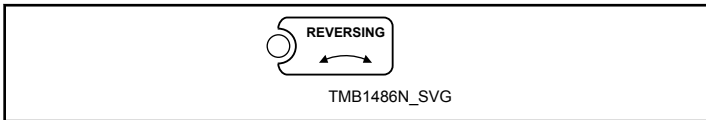

Figure 37

3. Press START pad to start tumble dryer.

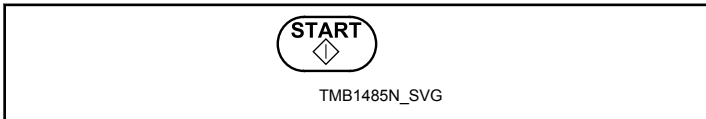

Figure 38

**NOTE: All pads can be pressed in any sequence without damaging control or tumble dryer. To stop the tumble dryer at any time, open the door or press STOP/RESET.**



Figure 39

**NOTE: The window display will flash. Press STOP/RESET twice (within three seconds) to end the cycle and reset the control to idle status. To restart the tumble dryer, CLOSE door and press START pad.**

**IMPORTANT: If the loading door or lint panel door is opened during the cycle, the heating system will shut off and the motor will stop. To restart the cycle, both doors must be closed and START pad must be pressed.**

4. When the cycle is complete, open door and remove the laundry.

	<b>WARNING</b>
To prevent the risk of fire, remove laundry immediately in case of power failure.	
W779	

**NOTE: This machine includes an anti-wrinkle/ extended tumble feature. After the drying cycle is complete, the cylinder will tumble without heat every few minutes. The intermittent tumbling will continue for one hour or until the door is opened.**

### Single Drop Control

SD and SX Control Suffixes

1. Select HIGH, MED, LOW or NO HEAT by turning the temperature knob.

HIGH	Temperature 190°F [88°C]
MED	Temperature 160°F [71°C]
LOW	Temperature 130°F [54°C]

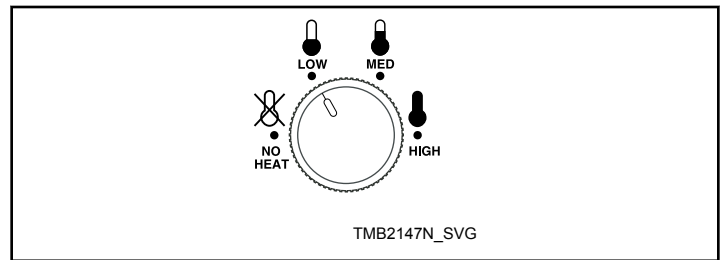

Figure 40

2. Insert the coin(s) in the coin slot.

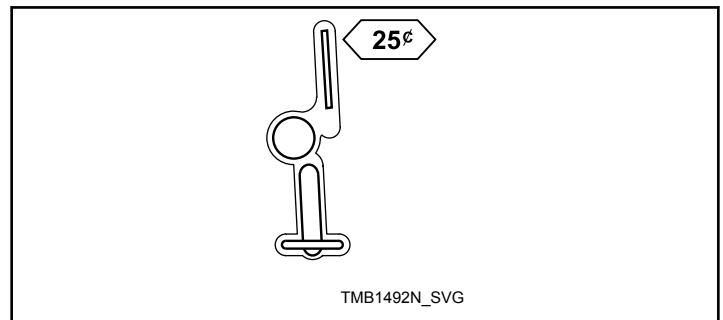

Figure 41

3. Press START button to start tumble dryer.

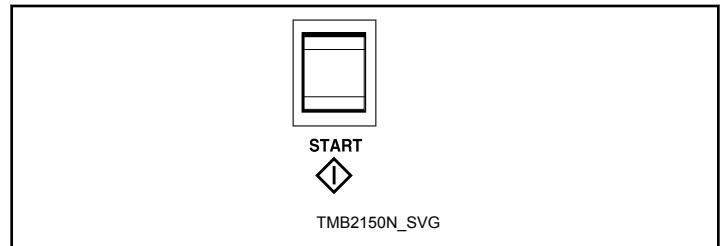



Figure 42

**IMPORTANT: To stop the tumble dryer at any time during the cycle, OPEN DOOR. To restart the tumble dryer, CLOSE door and press START button.**

4. When the cycle is complete, open door and remove the laundry.

	<b>WARNING</b>
<p>To prevent the risk of fire, remove laundry immediately in case of power failure.</p>	
W779	

**NOTE:** This machine includes an extended tumble feature. Starting 20 minutes after a cycle ends, the cylinder will tumble for two minutes every hour without heat, up to 18 hours or until door is opened.

**MDC Coin and Card Control**

BB, BC, BG, BK, BL, BW, BX, BY and BZ Control Suffixes

1. Select temperature by pressing the appropriate temperature pad.

HIGH	Temperature 190°F [88°C]
MED	Temperature 180°F [82°C]
LOW	Temperature 160°F [72°C]
DELICATES	Temperature 130°F [54°C]

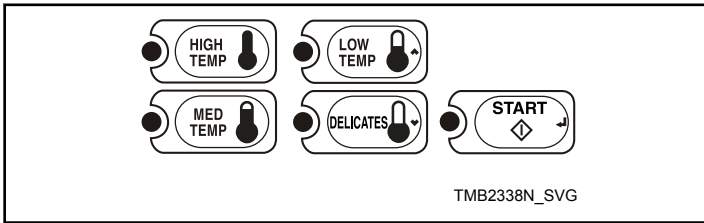

Figure 43

2. Insert the coin(s) in the coin slot, or the card into the opening.

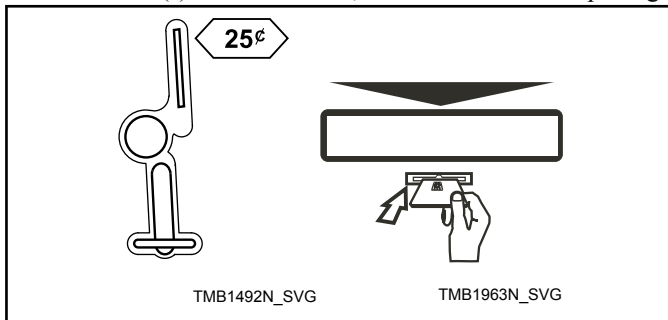

Figure 44

3. Press START pad to start tumble dryer.

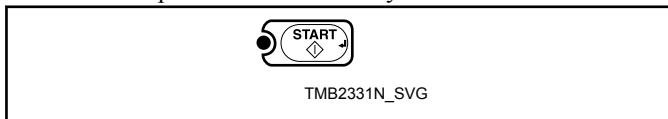



Figure 45

**IMPORTANT:** To stop the tumble dryer at any time during the cycle, OPEN DOOR. To restart the tumble dryer, CLOSE door and press START pad.

4. When the cycle is complete, open door and remove the laundry.

	<b>WARNING</b>
<p>To prevent the risk of fire, remove laundry immediately in case of power failure.</p>	
W779	

**Quantum Control**

LB, LC, LK, LL, LW, LX, LY, LZ, WB, WC, WK, WL, WW, WX, WY and WZ Control Suffixes

1. Select HIGH, MED, LOW, NO HEAT or DELICATES by pressing the appropriate temperature pad.

HIGH	Temperature 190°F [88°C]
MED	Temperature 180°F [82°C]
LOW	Temperature 160°F [72°C]
DELICATES	Temperature 130°F [54°C]

2. Insert the coin(s) in the coin slot or card into the card opening.

3. Press START pad to start tumble dryer.

**IMPORTANT:** To stop the tumble dryer at any time during a cycle, OPEN DOOR. To restart the tumble dryer, CLOSE door and press START pad.

4. When the cycle is complete, open door and remove the laundry.

	<b>WARNING</b>
<p>To prevent the risk of fire, remove laundry immediately in case of power failure.</p>	
W779	

**NOTE:** This machine includes an extended tumble feature. Starting 20 minutes after a cycle ends, the cylinder will tumble for two minutes every hour without heat, up to 18 hours or until door is opened.

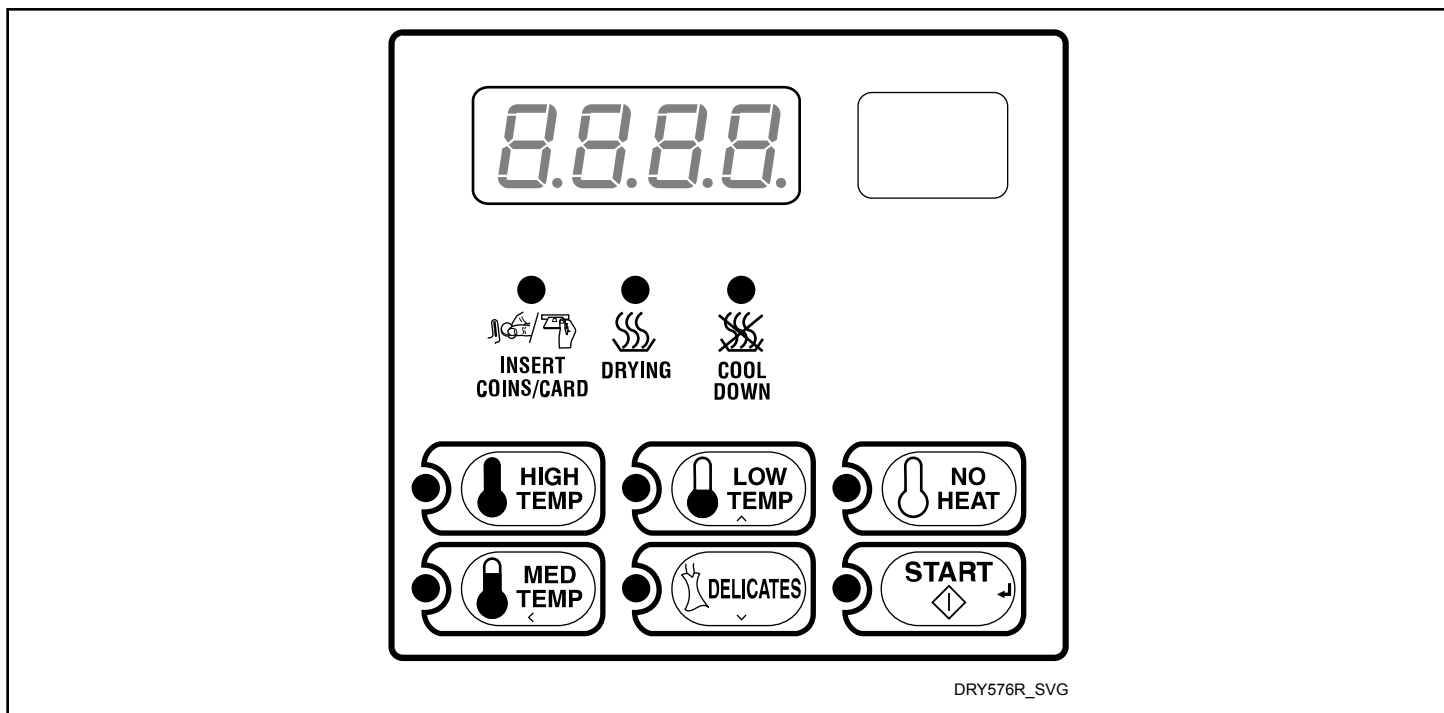

Figure 46

### Galaxy 600 Control

KB, KC, KK, KL, KW, KX, KY and KZ Control Suffixes

1. Select HIGH, MED, LOW or DELICATES by pressing the appropriate temperature pad.
 

HIGH	Temperature 190°F [88°C]
MED	Temperature 180°F [82°C]
LOW	Temperature 160°F [72°C]
DELICATES	Temperature 130°F [54°C]
2. Insert the coin(s) in the coin slot or card into the card opening.
3. Press START pad to start tumble dryer.

**IMPORTANT: To stop the tumble dryer at any time during a cycle, OPEN DOOR. To restart the tumble dryer, CLOSE door and press START pad.**

4. When the cycle is complete, open door and remove the laundry.

	<b>WARNING</b>
<p><b>To prevent the risk of fire, remove laundry immediately in case of power failure.</b></p>	
<p>W779</p>	

**NOTE: This machine includes an extended tumble feature. Starting 20 minutes after a cycle ends, the cylinder will tumble for two minutes every hour without heat, up to 18 hours or until door is opened.**

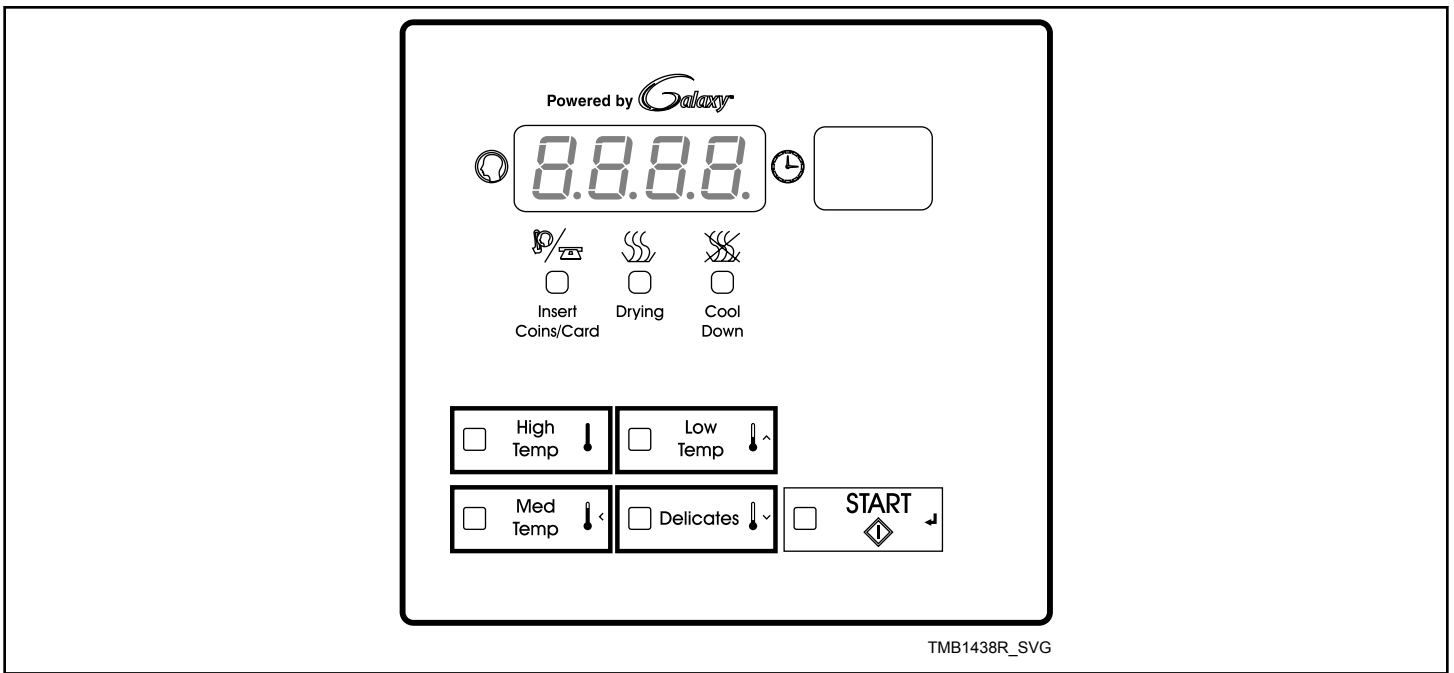

Figure 47

### LED OPL Control

#### EO and RE Control Suffixes

1. Press the Up or Down keypad to change cycles.  
To customize a cycle, refer to the Programming Manual.
2. Press START to start selected cycle.

**IMPORTANT:** If the loading door or lint panel door is opened during the cycle, the heating system will shut off and the motor will stop. To restart the cycle, both doors must be closed and the START pad must be pressed.

3. When the cycle is complete, open door and remove laundry.

	<b>WARNING</b>
To prevent the risk of fire, remove laundry immediately in case of power failure.	
W779	

**NOTE:** This machine includes an anti-wrinkle/extended tumble feature. After the drying cycle is complete, the cylinder will tumble without heat every few minutes. The intermittent tumbling will continue for one hour or until the door is opened. After an hour the machine enters delayed tumble and will tumble for two minutes every hour for up to 18 hours or until the door is opened.

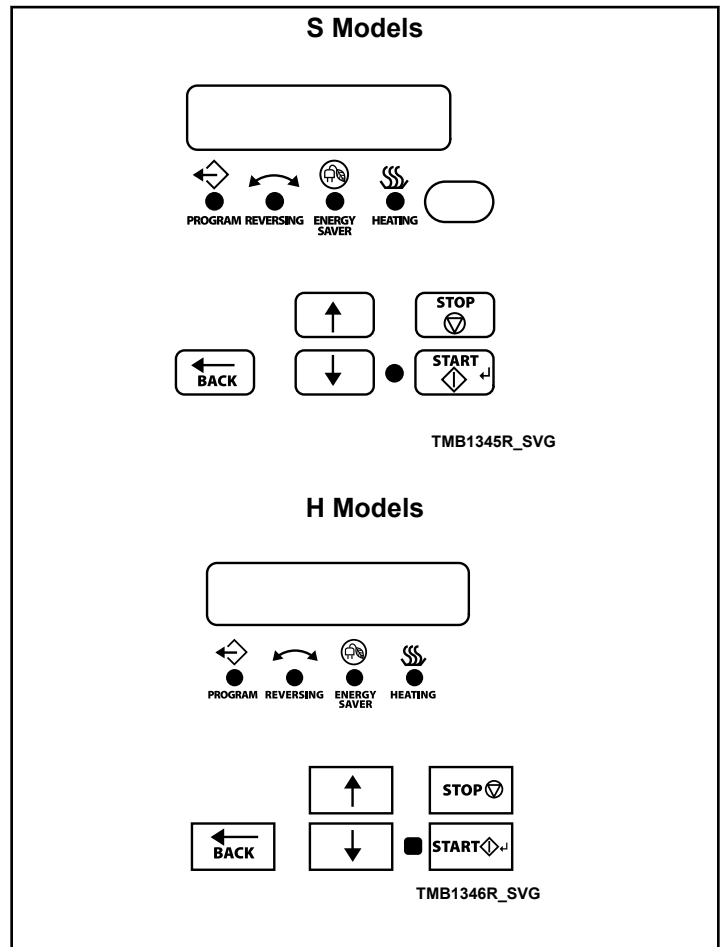

Figure 48

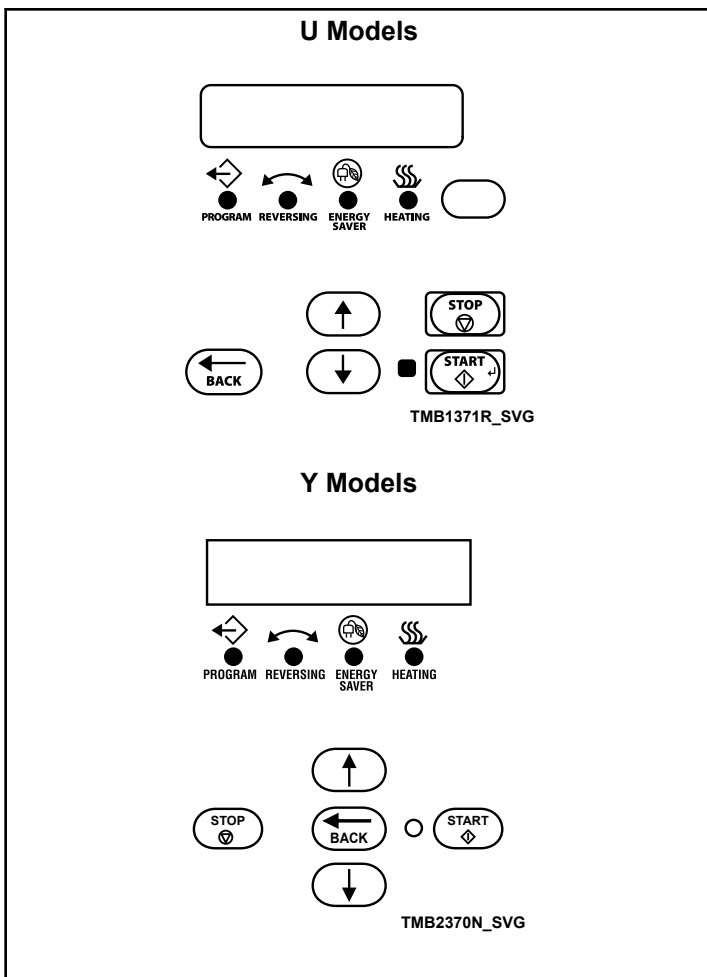

Figure 49

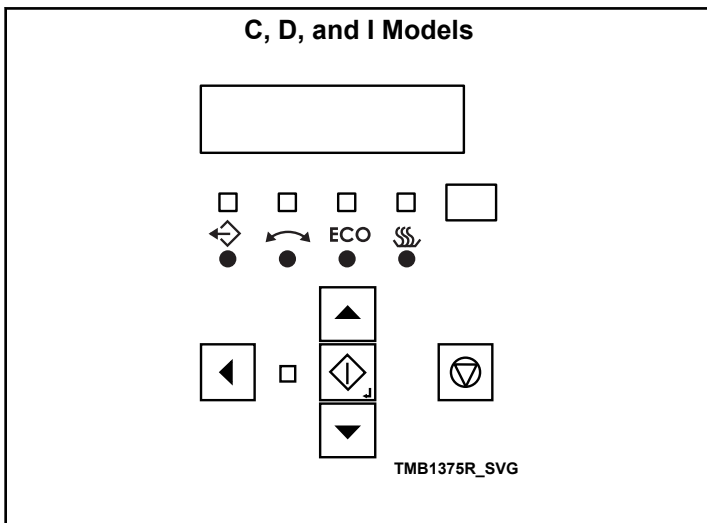

Figure 50

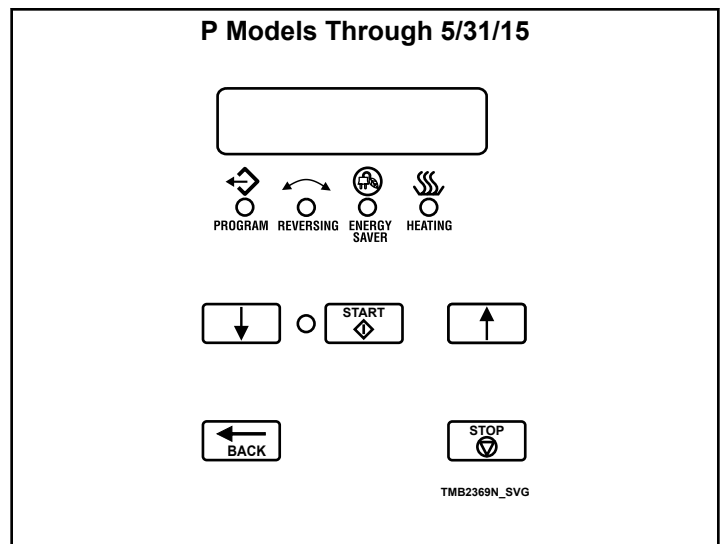

Figure 51

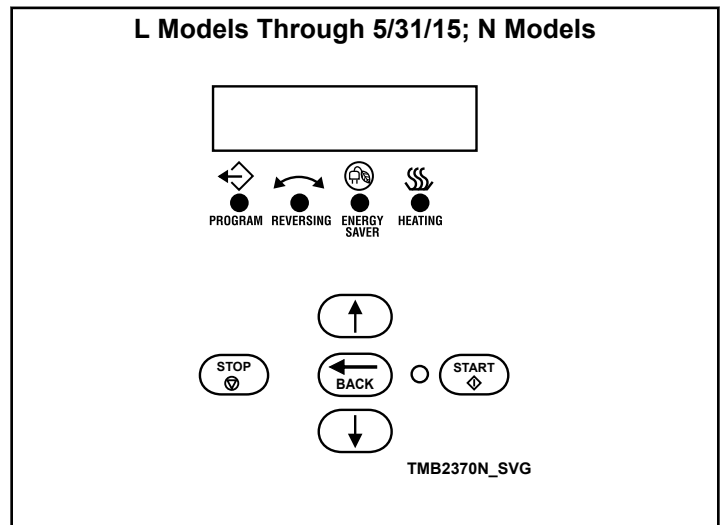

Figure 52

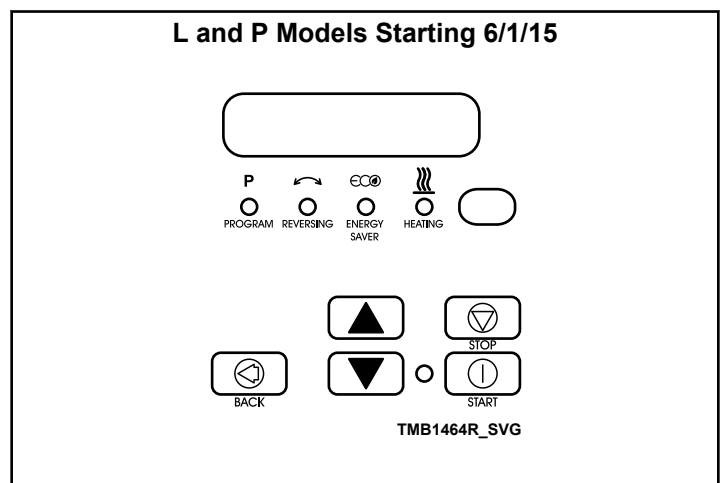





Figure 53

**UniLinc Control**

UO and RU Control Suffixes

1. Press the  or  keypad to change cycles. The center highlighted position is the selected cycle.  
To customize a cycle, refer to the Programming Manual.

2. Press START  to start selected cycle.

**IMPORTANT: If the loading door or lint panel door is opened during the cycle, the heating system will shut off and the motor will stop. To restart the cycle, both doors must be closed and the START  pad must be pressed.**

3. When the cycle is complete, open door and remove laundry.

**NOTE: This machine includes an anti-wrinkle/extended tumble feature. After the drying cycle is complete, the cylinder will tumble without heat every few minutes. The intermittent tumbling will continue for one hour or until the door is opened. After an hour the machine enters delayed tumble and will tumble for two minutes every hour for up to 18 hours or until the door is opened.**

	<b>WARNING</b>
To prevent the risk of fire, remove laundry immediately in case of power failure.	
W779	

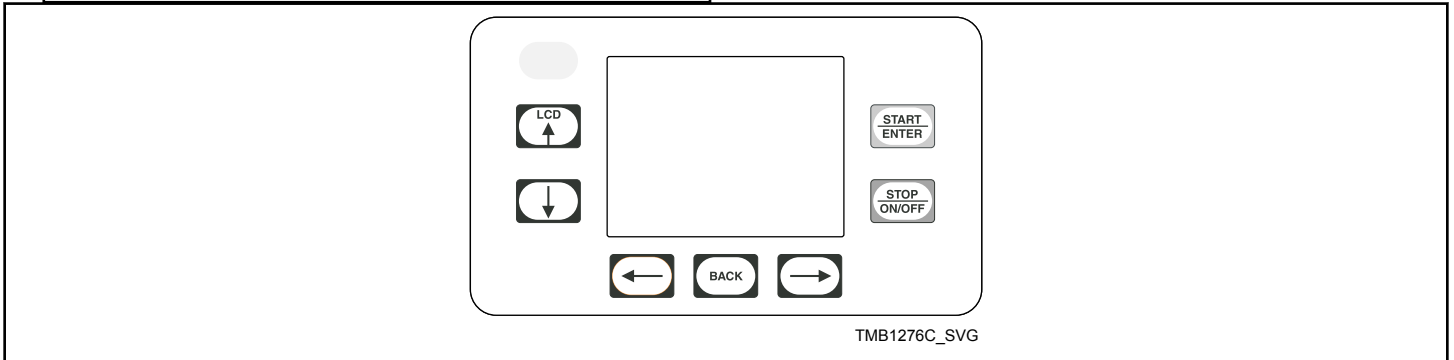

Figure 54

**DX4 Coin Control**

3B, 3K, 3L, 3V, 3W and 3X Control Suffixes

1. Open door and fill drum with clothes.
2. Close door.
3. Insert the coin(s) in the coin slot.
4. Press and release one of the cycle buttons to select a cycle and start the tumble dryer. Refer to *Table 29*.

To use a custom cycle, refer to the Programming Manual.

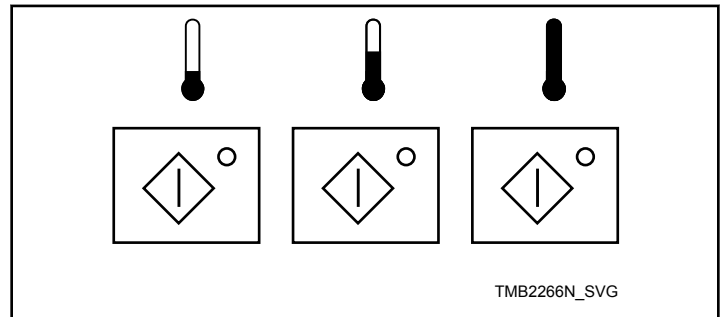

Figure 55



	Temperature	Drying Time	Cool Down Time
Left Button	104°F [40°C]	Varies	2 min.
Middle Button	140°F [60°C]	Varies	2 min.
Right Button	176°F [80°C]	Varies	2 min.

Table 29

**NOTE: Drying times will be dependent on the number of coins that are inserted in the coin slot.**

**IMPORTANT: To stop the tumble dryer at any time during the cycle, OPEN DOOR. To restart the tumble dryer, CLOSE door and press START button.**

- When the cycle is complete, open door and remove the laundry.

	<b>WARNING</b>
<b>To prevent the risk of fire, remove laundry immediately in case of power failure.</b>	
W779	

**DX4 OPL Control**

3O and R3 Control Suffixes

- Open door and fill drum with clothes.
- Press and release one of the cycle buttons to select a cycle and start the tumble dryer. Refer to *Table 30*.

To use a custom cycle, refer to the Programming Manual.

**Diagnostic Microprocessor Control  
General Operation**

The Diagnostic Microprocessor Control (DMP) is designed to manage the drying and cooling cycles of the tumble dryer. The controller is also programmed from the factory with five different default programs as described below. The operator has the flexibility to select the time for the drying and the cool down cycles and the drying temperature. The operator may also select either reversing or nonreversing basket action only if the tumble dryer is equipped for reversing. The operator may also reprogram the default programs. See Programming.

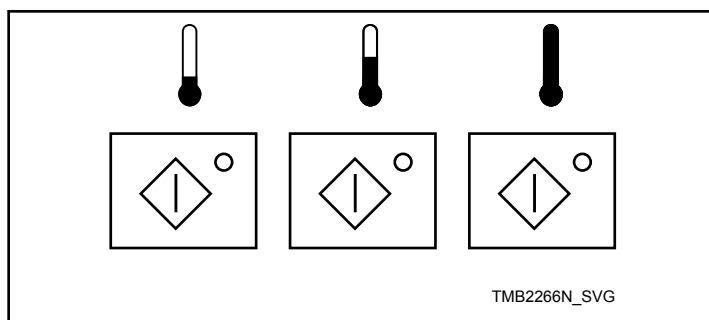



Figure 56

	Temperature	Drying Time	Cool Down Time
Left Button	104°F [40°C]	30 min.	2 min.
Middle Button	140°F [60°C]	30 min.	2 min.
Right Button	176°F [80°C]	35 min.	2 min.

Table 30

**IMPORTANT: To stop the tumble dryer at any time during the cycle, OPEN DOOR. To restart the tumble dryer, CLOSE door and press START button.**

- When the cycle is complete, open door and remove the laundry.

	<b>WARNING</b>
<b>To prevent the risk of fire, remove laundry immediately in case of power failure.</b>	
W779	

Default Programs	Dry Time (Min.)	Cool Time (Min.)	Temp. Set Point	Reversing
1 – Towels	40	5	185°/195°F [85°/91°C]	No
2 – Sheets	30	5	165°F [74°C]	Yes

*Table continues...*

Default Programs	Dry Time (Min.)	Cool Time (Min.)	Temp. Set Point	Reversing
3 – Misc-1	30	5	150°F [66°C]	No
4 – Misc-2	25	5	135°F [57°C]	Yes
5 – Extra Dry	5	2	150°F [66°C]	No

**NOTE: If an altered program is determined to be corrupted, the default program settings will be used.**

**Features**

- Drying time: 0-60 minutes
- Cooling time: 2-60 minutes
- LED display of cycle time, set temperature, and actual temperature
- Thermistor controlled temperature
- Safety tumble cycle
- Buzzer for end of cycle, audible alarm
- Reversing/Nonreversing selection
- Five user programmable programs
- RPM display – when equipped with rotational sensor only
- Monitors the lint door switch operation
- Monitors the thermistor for operation

The minimum drying time is 0 minutes, and the minimum cooling time is 2 minutes. The maximum drying or cooling time is 60 minutes. The drying temperature may be set from 100°F [38°C] to 185°/195°F [85°/91°C]. The drying time, cooling time, or temperature may be modified during an operating cycle.

If it is necessary to reset the drying and cooling times for the current cycle, press STOP once to stop the tumble dryer. Press STOP again to cancel the cycle.

If it is necessary to change programs during a current cycle, press STOP once to stop the tumble dryer and press STOP again to cancel the current cycle.

**Programming**

1. Set DIP switch #8 to the ON position.
2. Select the desired program number to change. The LED should be flashing.
3. Select DRY TIME. Set the time with the Up/Down arrows.
4. Select COOL TIME. Set the time with the Up/Down arrows.
5. Select TEMPERATURE. Set the temperature with the Up/Down arrows.

6. Select reversing REV (illuminated) or nonreversing REV (not illuminated). To change basket direction and dwell time, see Reversing Operation.
7. Press and hold the Program Select button about 3 seconds until the LED stops flashing. The selected program number is now programmed. If the Program button is pressed for less than 3 seconds, the controller will cancel the program and display the next program’s settings. If not programmed correctly, the display will flash “E2F” for 4 seconds, and the default settings will be used. Follow steps 4 through 7 to reprogram any program number. When finished, set DIP switch #8 to OFF. The programs are now stored.
8. During the Program Mode, if the Up/Down arrows, REV, or Display button is not pressed within 10 seconds, the default program settings will be used.
9. Temporary Reprogramming of Current Programs (OPL ONLY).
10. The Drying Time, Cooling Time, Temperature, and Reversing Mode of a program currently in use may be modified simply by adjusting any or all of the program parameters for that program, as needed. Once a modification has been made, the current program LED will flash indicating that it has been modified.
11. Use the Up/Down arrows to adjust program time.
12. Use the Display Select button to choose between Drying Time, Cooling Time, and Temperature. Then use the Up/Down arrows to adjust the times and temperature.
13. Toggle between reversing REV (illuminated) or nonreversing REV (not illuminated). (Only for tumble dryers with the reversing option.)
14. To cancel this temporary programming mode push the STOP button once to stop the current cycle and once more to cancel the modified program settings. The program will revert back to its original settings.

**Reversing Operation**

1. When the LOCAL reversing operation is selected, the reversing times are stored in the EEPROM which is located on the controller board. If the values stored are determined to be invalid, the clockwise and counterclockwise times will default to 60 seconds, and the dwell time will default to 4 seconds.
2. The reversing time program has the following sequence: (1) clockwise time, (2) dwell time and (3) counterclockwise time.
3. To program new reversing times DIP switches #3 and #8 must be on.
4. Press and hold the reverse button (REV) for 3 seconds to display the clockwise time.
5. Use the Up/Down arrows to set the clockwise time within the range of 30-120 seconds.
6. Press REV to display the dwell time.
7. Use the Up/Down arrows to change the dwell time within the range of 3-10 seconds.
8. Press the REV button to display the counterclockwise time.

9. Use the Up/Down arrows to change the counterclockwise time within the range of 30-120 seconds.
10. Press the REV button to save these settings and leave DIP switch #3 in the ON position and flip DIP switch #8 to the OFF position.

When the DMP controller is retrofitted to an existing tumble dryer with the reversing feature, off board reversing will be required and DIP switch #3 on the DMP must be in the OFF position and the DMP must be connected to the Reversing Timer Board for proper operation. The DMP settings for clockwise, dwell, and counterclockwise times are no longer valid when used with the Reversing Board. Instead these settings are made on the Reversing Timer Board.

#### **Rotation Sensor**

The rotation sensor must “read” the key on the basket shaft or pulley. The sensor must be set approximately 1/4 inch from the key or pulley. Look for the light on the sensor to come on as the key passes the sensor; this is a correctly operating sensor. If no light appears, either the sensor is out of range or the key/pulley or

#### **DMP OPL Models**

DO Control Suffix

the sensor is bad. In addition, if the light stays on continuously, then the sensor is too close to the component or the sensor is bad.

#### **Safety Tumble/Anti-Wrinkle**

At the end of the cool down cycle, the tumble dryer will stop and display “END.” The DMP control will automatically rotate the basket for 5 seconds every 2 minutes for a total of 20 minutes, until some function of the tumble dryer is activated/deactivated by the user.

#### **Operational Check for the Board Diagnostics**

1. “dor” indicates that the loading or lint door is open.
2. Cycle the tumble dryer to check if the buzzer activates.
3. “P-F” indicates that the thermistor is short circuited or open circuited.
4. “bbt” indicates a broken belt condition or a faulty rotation sensor. (Only available on tumble dryers with the rotation sensor.)
5. Hold the START button to display the drum RPM’s; the display will read “r##” where ## are the RPM’s. (Only available on tumble dryers with the rotation sensor.)

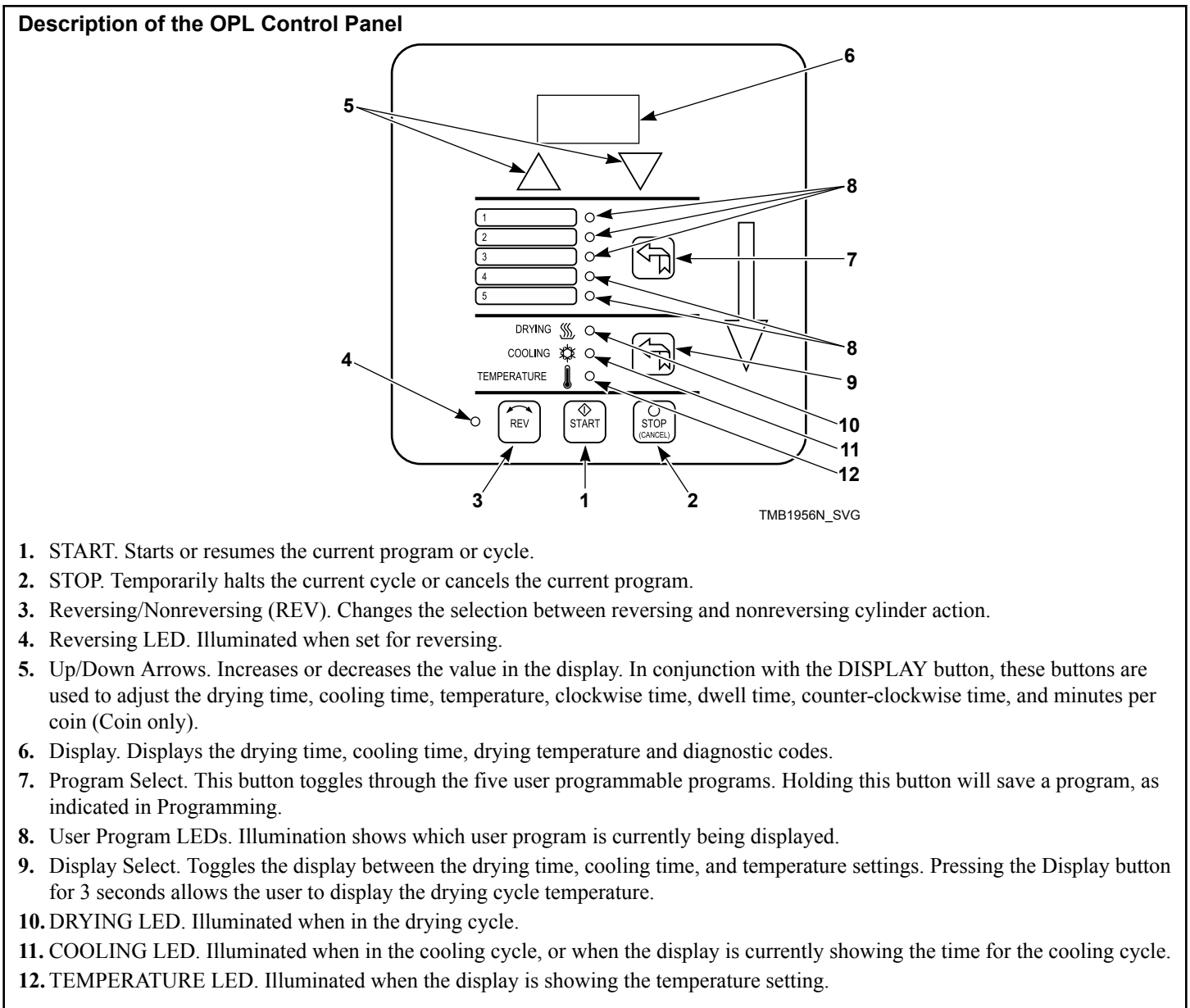

Figure 57

The DMP has an 8 position DIP switch bank that is accessible from the back of the control board. By switching these DIP

switches, it is possible for the operator to customize the display and some of the operating features of the tumble dryer.

Function	OPL		Coin		
	1	2	3	4	
1	Tumble dryer Type	OFF	ON		OPL=Off; Coin=On
2	Temperature Units	OFF	OFF		°F=Off; °C=On
3	Local/Remote Reversing	ON	ON		Local=On; Remote=Off

*Table continues...*

Function	OPL	Coin				
4	Empty	ON	ON	Always ON		
5	Empty	ON	ON	Always ON		
6	Buzzer Timer	ON	ON	5 Sec=Off; Continuous=On		
7	Safety Tumble (OPL) or Coin Count/Pay (Coin)	ON	OFF	#1	#7	DIP SWITCH
				OFF	ON	SAFETY TUMBLE
				OFF	OFF	NO SAFETY TUMBLE
				ON	ON	COIN COUNT
				ON	OFF	PAY
8	Programming	OFF	OFF	Disable=Off; Enable=On		

**DIP Switch Functions Explained**

1. Tumble dryer Type: This DIP switch selects the type of tumble dryer, i.e., OPL or Coin.
2. Temperature Units: Selects °F or °C for the temperature display. Factory setting is for °F.
3. Local/Remote Reversing: Preset at the factory; usually for local reversing. Remote reversing for use with Reversing Timer Board only.
4. Empty: Preset at the factory; always ON.
5. Empty: Preset at the factory; always ON.
6. Buzzer Timer: This DIP switch determines the length of time that the end of cycle buzzer will remain on. "OFF" indicates

that the buzzer will sound for 5 seconds when the drying cycle is completed. "ON" indicates that the buzzer will sound continuously until the STOP button is pressed or the loading door is opened.

7. Safety Tumble (OPL) or Coin count/Pay (Coin): If DIP switch #1 is set for OPL, then DIP switch #7 in the ON position enables the safety tumble. If DIP switch #1 is set for Coin, then DIP switch #7 in the ON position enables the display of the coin count. DIP switch #7 in the OFF position enables the display of "PAy", to indicate that coins are needed to run the tumble dryer.
8. Programming: This switch enables or disables the programming feature and should normally be in the OFF position.

**DMP Coin**

DV and DX Control Suffixes

### Description of The Coin Control Panel

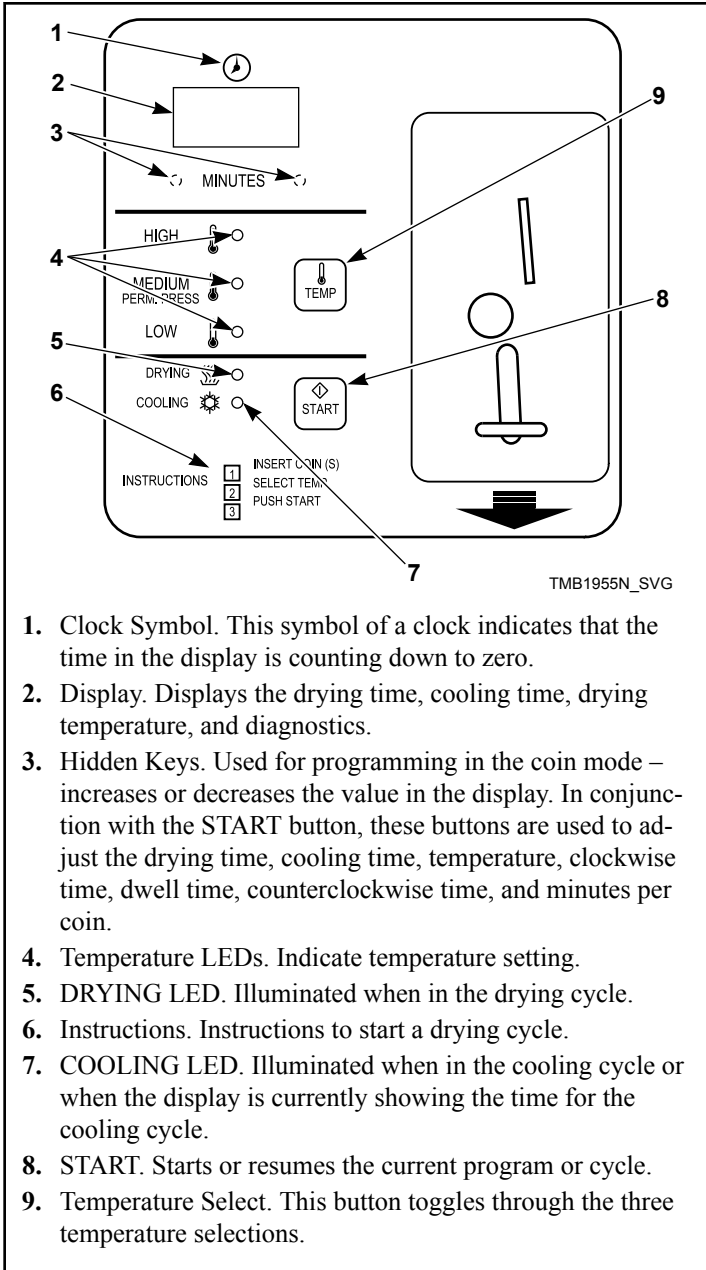

1. Clock Symbol. This symbol of a clock indicates that the time in the display is counting down to zero.
2. Display. Displays the drying time, cooling time, drying temperature, and diagnostics.
3. Hidden Keys. Used for programming in the coin mode – increases or decreases the value in the display. In conjunction with the START button, these buttons are used to adjust the drying time, cooling time, temperature, clockwise time, dwell time, counterclockwise time, and minutes per coin.
4. Temperature LEDs. Indicate temperature setting.
5. DRYING LED. Illuminated when in the drying cycle.
6. INSTRUCTIONS. Instructions to start a drying cycle.
7. COOLING LED. Illuminated when in the cooling cycle or when the display is currently showing the time for the cooling cycle.
8. START. Starts or resumes the current program or cycle.
9. Temperature Select. This button toggles through the three temperature selections.

Figure 58

### Coin Keypad Interface

- START button to start or resume a cycle.
- TEMP button to select HIGH, MEDIUM, or LOW temperature.
- Two hidden buttons to increment or decrement the programmable time and temperature options.

### Power-Up

Upon applying power to the tumble dryer, the display will show “PAy” and the DRYING and COOLING LEDs will be off until coins are deposited to increase the tumble dryer run time. When

time is displayed, the default (LOW) temperature setting LED will be on until a different temperature setting is selected.

### Power Failure

If a power loss occurs during operation, a cycle will not resume until the START button is pressed. To cancel the remaining cycle, press the internal CLEAR button.

### Coin Operation

The tumble dryer run time is determined by the pre-programmed run time per coin and the number of coins deposited into the tumble dryer. The maximum time that can be accumulated and displayed is 99 minutes. The drying time is the difference between the run time and the cooling time. The cooling time is pre-programmed to be 2 to 5 minutes. The drying temperature can be selected from LOW, MEDIUM, or HIGH temperature settings by pressing the TEMP button.

### Coin Programming

The Coin board programming mode can only be entered when “PAy” is displayed. DIP switch #7 must be in the off position.

Programming is enabled by setting DIP switch #8 to the ON position.

The programming mode is entered by pressing and holding the CLEAR button for three seconds.

The programming follows the following parameter order:

1. Tumble dryer run time per coin (DRYING), COOLING time, HIGH temperature setpoint, MEDIUM temperature setpoint, LOW temperature setpoint.
2. An LED will be on to indicate which parameter is flashing on the display.
3. The hidden front panel increment and decrement keys are used to change the value.
4. The CLEAR button is used to recall the default value.
5. The START button is used to step to the next parameter.
6. After the last parameter, “End” will be flashing.
7. Press the START button one last time to store the settings and exit the program mode.
8. “PAy” will be displayed.
9. If it is determined that the data did not program correctly, the error message “E2F” will flash for 4 seconds, and then the default coin parameters will be used.

The tumble dryer run time per coin is programmable for 1 to 20 minutes with the default preset to 10 minutes.

The cooling run time is programmable from 2 to 5 minutes with the default preset to 2 minutes.

The three temperatures setpoints are programmable for 100°F [38°C] to 185°F/195°F [85°/90°C] with the following default settings:

- HIGH equal to 185°F [85°C]
- MEDIUM equal to 150°F [66°C]

- LOW equal to 135°F [57°C]

**Stop**

When in the Coin mode, the tumble dryer will stop if the tumble dryer door is opened while the tumble dryer is running. If the CLEAR button, located behind the board, is pressed, the tumble dryer will stop, the tumble dryer time will be zeroed and the display will show “PAy”.

**Coin Count**

The unit will count the number of coins deposited.

Setting DIP switch #7 to the ON position will display the coin count since it was the last reset.

To reset the count, press the CLEAR button and “00” will be displayed.

If the coin count is greater than “999”, the display will flash “999”.

Setting DIP switch #7 to the OFF position will return the display to “PAy”.

**Ignition Control Operation and Troubleshooting for Models Starting 3/11/13**

	<b>WARNING</b>
<p><b>70458601 and 70458701 controls cannot be serviced by the user. If any control failures are detected, the controls must be replaced by qualified service personnel. Risk of explosion or fire can result if the control module has been opened or with any attempts to repair it and the warranty is void.</b></p>	
W818	

Before troubleshooting the system, check the following items:

**Troubleshooting**

<b>Troubleshooting Guide</b>	
<b>Symptom</b>	<b>Probable Cause</b>
Control in Lockout Mode (70458701 Control Only)	Manual reset of the control is needed. Reset by pushing red lockout button or use front end control.
Control does not start, green LED is off	<ol style="list-style-type: none"> <li>24 VAC present between 24V and ground on 70458701 only. If not, see machine schematic.</li> <li>24 VAC present between TH and ground. If not, see machine schematic.</li> </ol>

*Table continues...*

- Verify all mechanical and electrical connections are secure and tight.

- Verify all system wiring is correct.

- Verify there is a proper system ground. The igniter, flame sensor and igniter module must share a common ground with the burner. Nuisance shutdowns are often caused by a poor or erratic ground.

- Verify that the system is powered and that the control is calling for heat.

- If the control proceeds to an error code on the red diagnostic LED, troubleshoot per the Fault conditions table below:

<b>Fault Conditions</b>	
<b>LED Indication</b>	<b>Fault Mode</b>
Off	Normal Operation
1 Flash	At Power Up
2 Flashes	Flame Without Call For Heat
3 Flashes	Ignition Lockout
4 Flashes (70458701 only)	Manual Reset Error
Steady On	Internal Control Failure

**NOTE: The LED will flash on for 1/4 second, then off for 1/4 second during a fault condition. The pause between fault codes is 3 seconds.**

**Internal Control Failure**

If the control detects an error in its software or hardware, all outputs are turned off and the red LED displays a steady ON condition. If this condition persists after an attempt to restart, then the control must be replaced.

<b>Troubleshooting Guide</b>	
Thermostat on, no spark or valve	<ol style="list-style-type: none"> <li>1. Cable connects to control and electrode. Voltage present at gas valve.</li> <li>2. Bad control. Check red LED for steady on or flashing codes.</li> </ol>
Valve on, no spark during TFI	<ol style="list-style-type: none"> <li>1. Shorted electrode.</li> <li>2. Spark gap not correct. Set to .094-.156 inch.</li> <li>3. High voltage cable is faulty or has a poor connection.</li> <li>4. Control failure.</li> </ol>
Spark on, no flame	<ol style="list-style-type: none"> <li>1. Is gas on?</li> <li>2. 24 VAC at gas valve.</li> <li>3. Bad control. Check voltage between gas valve terminal MV and GND on control.</li> </ol>
Flame okay during TFI, no flame sense after TFI	<ol style="list-style-type: none"> <li>1. Check electrode position and cleanliness.</li> <li>2. Check high voltage wire.</li> <li>3. Poor ground at burner.</li> <li>4. Poor flame, check flame current.</li> </ol>
Reset failure	<ol style="list-style-type: none"> <li>1. Reset switch was pressed too long. Try to reset again.</li> <li>2. Reset switch is shorted. Replace switch.</li> </ol>

**Proper Electrode Location**

Proper location of the electrode assembly is important for optimal system performance. The electrode assembly should be located so that the tips are inside the flame envelope and about 1/2 inch [1.2 cm] above the base of the flame. Refer to *Figure 59* .

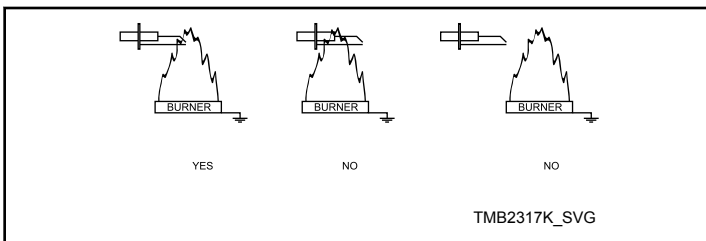

Figure 59

**Flame Current Measurement**

Flame current is the current that passes through the flame from sensor to ground. To measure flame current, connect a True RMS or analog DC micro-amp meter to the FC+ and the FC- terminals. The reading should be 1.0 micro-amps DC or higher. If the meter reads negative or below “0” on the scale, the meter leads are reversed. Re-connect leads with proper polarity.

Alternately, a Digital Voltmeter may be used to measure the DC voltage between the FC+ and FC- terminals. Each micro-amp of

flame current produces 1.0 VDC, so a reading of 2.6 VDC would equate to 2.6 micro-amps.

A good burner ground that matches the control ground is critical for reliable flame sensing.

**Ignition Control Operation for Non-CE Models Through 3/10/13**

**Power Up**

When power is applied to the ignition control, the control will begin the ignition sequence within 1 – 3 seconds prepurge waiting time.

**Ignition Sequence**

The control begins the ignition sequence after prepurge by powering the ignitor and opening the gas valve. The ignitor will remain on either until a flame is sensed or until a maximum of ten (10) seconds(10 +0/-4 sec) has elapsed. If a flame is established and lost during the 10 second period, the ignitor will be powered up again in an attempt to re-ignite the gas.

If no flame is detected within the ten (10) second ignition sequence, the control will terminate power to the gas valves, ignitor, and enter lockout within 5 seconds.



## Normal Operation

Once a flame has been established, the spark igniter will stop sparking and the control will continually monitor all inputs. If the controller senses a loss of flame after flame is established, the gas valve will remain energized and sparking will commence within one second of the flame loss. If flame reattempt fails, lockout will occur within 11 seconds of initial flame loss.

## Termination of Flame

Normal flame termination occurs when the thermostat has been satisfied, meaning there is no immediate need for more heat. The thermostat will disconnect power from the ignition control, which will cause the gas valve to close and the flame to go out. After a short period of time, not less than 1 second, the thermostat will cool down and close causing power to be reapplied to the ignition control. When this occurs, the control must complete the same prepurge and ignition sequence specified above.

## Control Lockout

When the control locks out, the gas valve will be closed and all requests for heat will be ignored. The lockout mode may only be discontinued by interrupting power to the control or cycling the thermostat. After this occurs, the control will restart with its normal power up and ignition sequence.

## Low Voltage Detection

The control will have capability for detection of a low voltage input condition. If input voltage on power up is below 19.0VAC +0.8VAC/-0.5VAC, the control will disable output to gas valve control relay. If input voltage rises above 19.8VAC for at least three (3) seconds, the control will then re-enable function of the gas valve control relay and ignition sequence may begin. On powerup, the control function must always be disabled if greater than 19.8VAC.

## Ignition Control Operation for CE Models Through 3/10/13

### Power Up

After 24VAC is applied to the ignition control pins 24V and GND, the Diagnostic LED on the ignition control will turn orange/yellow. If a fault is detected the ignition control will enter Lockout Mode. If no faults are detected, the Diagnostic LED will turn Green and the ignition control will enter Standby Mode.

### Standby Mode

While in Standby Mode, the ignition control will continually monitor the system for faults. Once 24VAC is applied to terminals TH and GND on the control, the ignition control will enter Start Up Mode.

### Start Up Mode

During Start Up Mode, the ignition control will monitor the system for faults and begin the ignition sequence. If no faults are

present, the ignition control will begin the ignition sequence by entering an 18 second waiting period. During this time the Green LED on the ignition control will switch between Red and Green, before maintaining a Green color.

After the waiting period, the ignition control will turn on the igniter and gas valve. The igniter will remain on until a flame is sensed, or up to 10 seconds.

Once a flame has been sensed the ignition control will stop sparking, the gas valve will remain on and ignition control will enter Run Mode.

If a flame is not sensed, the ignition control will then begin two additional retrials for ignition. The ignition control will re-enter the 18 seconds waiting period before the ignition control makes another attempt at ignition. If the three attempts at ignition fail, the ignition control will enter Lockout Mode.

## Run Mode

While in Run Mode the ignition control leaves the gas valve on, monitors the flame signal, and leaves the igniter off.

If a flame signal is lost during Run Mode, one additional retrial for ignition will take place within one second. The ignition control will restore the spark for approximately 10 seconds. If the ignition re-attempt fails, the ignition control will enter Lockout Mode.

The ignition control will remain in Run Mode until 24VAC is removed from terminals TH and GND on the control.

## Termination of Flame

The flame will go out when power is removed from ignition control. The ignition control will turn off the gas valve and enter Standby Mode.

## Lockout Mode

When Lockout Mode is entered, the ignition control will remove power to the gas valve, the igniter will turn off, the Lockout/Reset Light will turn on, and the Diagnostic LED will display the appropriate Error Code.

## Lockout Manual Reset

Lockout Mode is cleared by pressing an external reset switch for three seconds. The ignition control will clear all error codes and enter Standby Mode. During Lockout Manual Reset, the Diagnostic LED on the ignition control flashes red and orange, and the Reset Light remains on until the ignition control is reset. After the Reset Light turns off, stop pressing the switch. Holding the reset for three seconds after lockout has been cleared will cause a fault and result in entering Lockout Mode again.

## System Tests

The following system tests are performed during normal operation. System tests are performed at a minimum of every 24 hours.

**Low Voltage Detection**

If the voltage between terminals TH and GND on the control is below 18.75VAC +/- 0.75VAC for more than 3 seconds the ignition control will turn off the gas valve and will not attempt to spark. The Diagnostic LED will display Error Code 5. The ignition control will not enter Lockout Mode if a low voltage condition is detected, but will enter Standby Mode and wait for the low voltage condition to be cleared.

If the voltage between terminals TH and GND on the control rises above 19.75VAC +/- 0.1VAC for at least 3 seconds, the ignition control will then enter Start Up Mode.

Low Voltage Detection test is disabled during Run Mode.

**Gas Valve**

The ignition control verifies that the gas valve is connected. Failure of this test results in the ignition control entering Lockout Mode with the Diagnostic LED displaying Error Code 2.

**Flame Probe Tests**

The Unexpected Presence of Flame test is performed when no flame is expected. Failure of this test results in the ignition control entering Lockout Mode with the Diagnostic LED displaying Error Code 3.

During the Flame Monitoring test, the flame is checked to ensure the gas is being burned when the gas valve is on. Failure of this test will result in the ignition control entering Lockout Mode with the Diagnostic LED displaying Error Code 3.

**Diagnostic LED (DGN LED)/Error Codes**

The Diagnostic LED or DGN LED is located by the power connector on the ignition control. Refer to *Figure 60* . The Diagnostic LED will indicate the status of the ignition control. Refer to *Table 31* .

LED Color	Description
Orange-Yellow	Initialization
Green	Standby/Normal Operation
Red	Fault Indication Code

Table 31

The Diagnostic LED will flash error codes one half second on and one half second off. Error codes are separated by a one second pause before the code is repeated.

Error Code	DGN LED status	Fault Type
1	Red	Ignition Control Internal Failure
2	2 Red Flashes	Gas Valve Not Connected
3	3 Red Flashes	Ignition/Flame Sense Failure
4	4 Red Flashes	Reset Switch is Shorted
5	Slow Red and Green Flashes	Low Voltage Detection
6	Fast Red and Orange Flashes	Ignition Control is in Reset Delay

TMB2176N\_SVG

1. Diagnostic (DGN) LED

Figure 60

# Adjustments

## Adjustments

	<b>WARNING</b>
<p>To reduce the risk of electric shock, fire, explosion, serious injury or death:</p> <ul style="list-style-type: none"> <li>• Disconnect electric power to the tumble dryer before servicing.</li> <li>• Close gas shut-off valve to gas tumble dryer before servicing.</li> <li>• Close steam valve to steam tumble dryer before servicing.</li> <li>• Never start the tumble dryer with any guards/panels removed.</li> <li>• Whenever ground wires are removed during servicing, these ground wires must be reconnected to ensure that the tumble dryer is properly grounded.</li> </ul>	
W002R1	

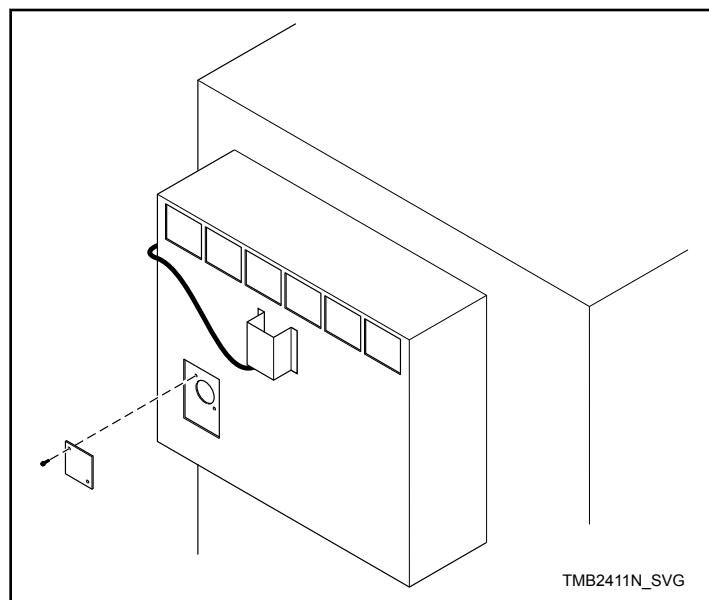

Figure 61

## Gas Burner Air Shutter

**NOTE:** Air inlet shutters on the burner must be adjusted so sufficient air is metered into the system for proper combustion and maximum efficiency. Before adjusting the inlet shutters be sure that all lint is removed from lint compartments and lint screen.

Air shutter adjustments will vary from location to location and will depend on the vent system, number of units installed, make-up air and line gas pressure. Opening the shutter increases the amount of primary air supplied to the burner while closing the shutter decreases the primary air supply. Adjust air shutter as follows:

Refer to *Figure 61* .

1. Remove the burner inspection hole plate.

2. Start the tumble dryer and check the flame pattern. If the flame pattern is straight up, insufficient air is flowing through the tumble dryer. A flame pattern that flares to the right and left indicates no air is flowing through the tumble dryer. Correct air and gas mixture is indicated if the flame pattern is primarily blue, with small yellow tips, and bends to the right of the heater section. Too little air is indicated if the flame is yellow, lazy and smokey. (A whistling sound from burner could also be caused by an improper air shutter setting.)
3. To adjust the air shutter, loosen air inlet shutter adjusting screw.
4. Open or close air shutter as necessary to obtain proper flame intensity.
5. After air shutter is adjusted for proper flame, tighten air shutter adjusting screw securely.

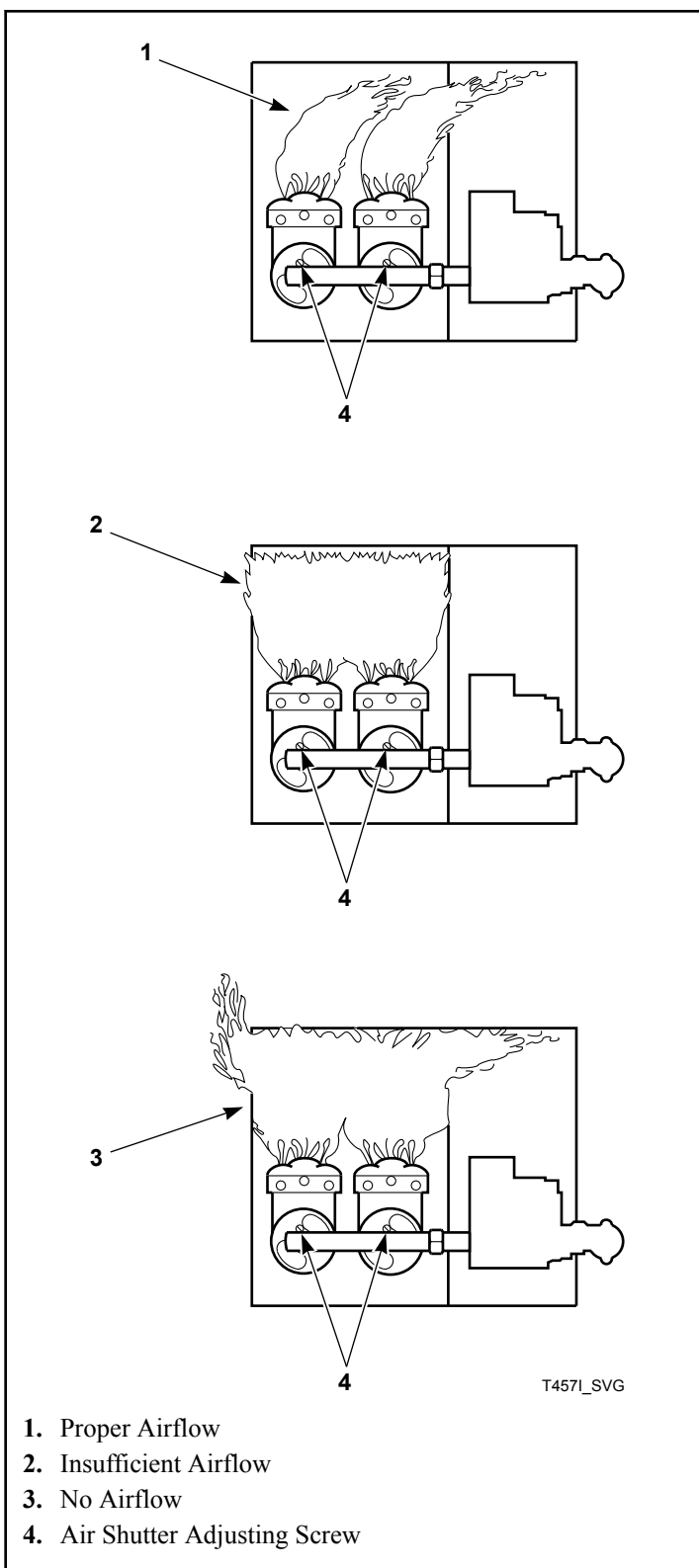

Figure 62

## Airflow Switch

The airflow switch is set at the factory for proper operation. No adjustment necessary.

The airflow switch operation may be affected by shipping wire tie still in place, lack of make-up air, or an obstruction in the exhaust duct. These should be checked and the required corrective action taken.



## WARNING

**The tumble dryer must not be operated if the airflow switch does not operate properly. Faulty airflow switch operation may cause an explosive gas mixture to collect in the tumble dryer.**

W072R1

**IMPORTANT:** Airflow switch vane must remain closed during operation. If it opens and closes during the drying cycle, this indicates insufficient airflow through the tumble dryer. If switch remains open, or pops open and closed during the cycle, the heating system will shut off. The cylinder and fan will continue to operate even though the airflow switch is indicating insufficient airflow.

**NOTE:** To properly mount the airflow switch bracket, or in case of a load not drying, the airflow switch bracket may need to be checked for proper alignment. Be sure the locator pins are securely in their respective holes before tightening the bracket mounting screws. This will assure proper alignment of the airflow switch arm in the channel of the airflow switch bracket and prevent binding of the arm.

## Loading Door Switch

The door switch should be adjusted so the cylinder stops when door is opened 2 inches [51 mm] plus or minus 0.25 inch [6 mm]. This switch is a normally open switch and is closed by the hinge cam when the door is closed. If adjustment is required, refer to *Figure 63* and proceed as follows:

1. Close door and start tumble dryer, slowly open loading door. Cylinder and heat system should shut off when door is open 2 inches [51 mm] plus or minus 0.25 inch [6 mm].
2. Slowly close the loading door. When door is 2 inches [51 mm] from being fully closed, the door switch actuating bracket (located on the door) should depress the button and the switch arm with an audible "click."
3. If the actuating bracket does not operate the switch at the appropriate door closure, bend the actuating switch arm in or out to achieve proper actuation.

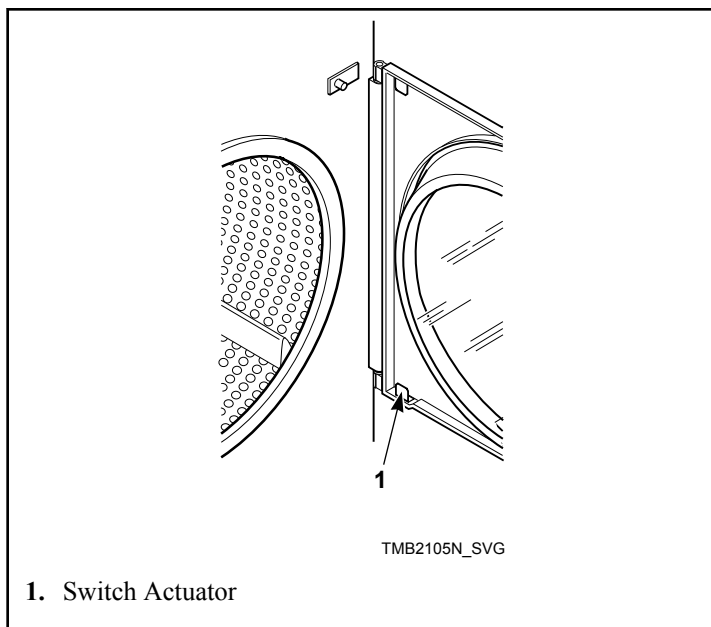

Figure 63

## Door Strike

The door strike must be adjusted to have sufficient tension to hold loading door closed against force of the load tumbling against it. There is proper adjustment of pull force when 8 to 15 pounds [35.6 N – 66.7 N] is required to open door.

If adjustment is required, refer to *Figure 64* and proceed as follows:

1. To adjust, open door, loosen acorn nut, and turn door strike screw in or out as required.
2. Retighten acorn nut.

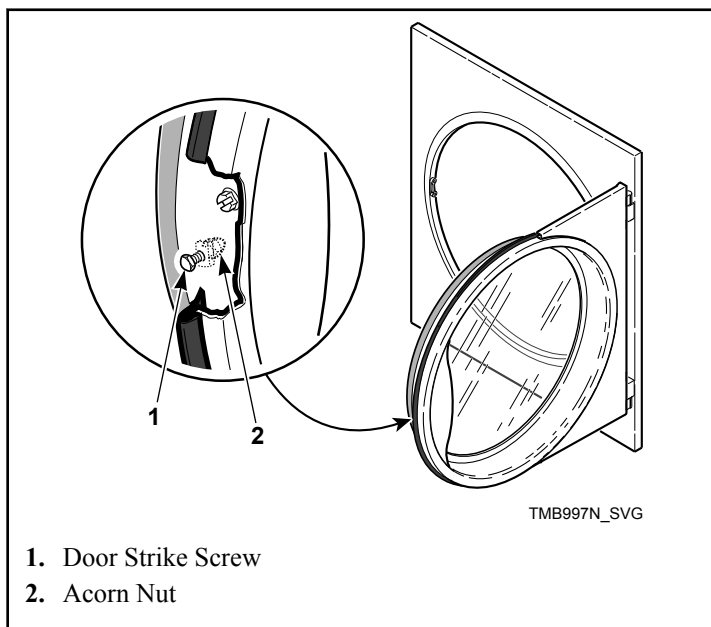

Figure 64

# Maintenance

## Daily

1. Inspect the area surrounding tumble dryers, remove all combustible materials, including lint, before operating the machines.
2. Check cylinder for foreign objects to avoid damage to clothing and equipment.
3. Clean lint from lint compartment and screen to maintain proper airflow and avoid overheating.



### WARNING

**To reduce the risk of serious injury, do not open the lint panel while the tumble dryer is in operation. Before cleaning the lint screen, open tumble dryer door and allow cylinder to completely stop.**

W410R1

- a. Open the lint panel. On stack models, open the lint drawer.
  - b. Remove all accumulated lint in the lint compartment area. Lightly brush any lint that may be left on the lint screen.
  - c. Be sure the lint screen is not torn.
  - d. The lint screen is designed to completely cover the entire opening in the lint screen panel. Be sure that it does so.
  - e. Wipe lint off of the cabinet high limit thermostat and thermistor. Refer to *Figure 65* and *Figure 66*.
  - f. Replace the lint compartment panel on the tumble dryer ensuring a tight fit, and lock if applicable.
4. At end of day, clean the machine's top, front and side panels with mild detergent. Rinse with clean water. **DO NOT** use products that contain alcohol on the control panel.

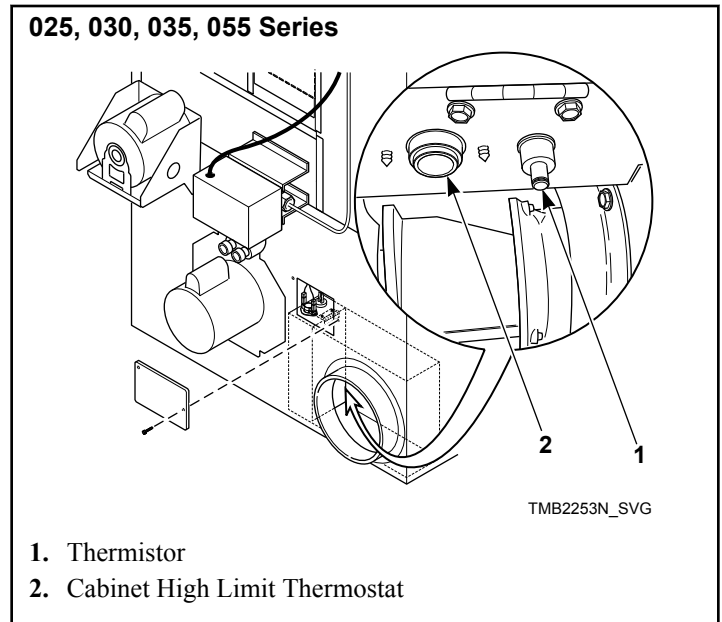

Figure 65

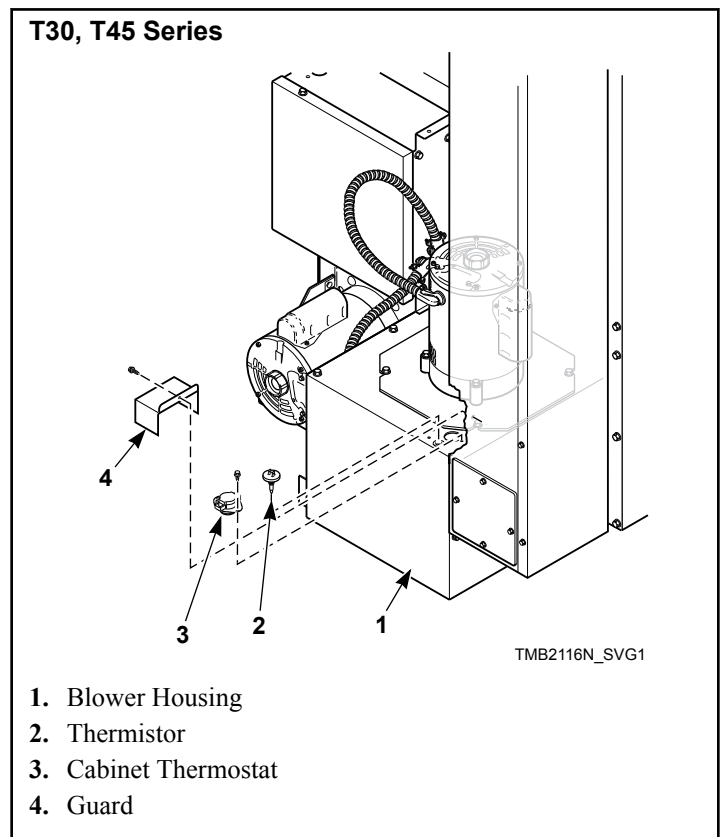

Figure 66

## Monthly

1. Remove lint and debris from inside exhaust duct to maintain proper airflow and avoid overheating.
  - a. Remove external duct and duct access covers, if present.
  - b. Clean inside of duct with a vacuum.
  - c. Clean dampers and make sure they operate freely.
  - d. Replace duct and all access covers before returning tumble dryer to operation.
2. Ensure even lint distribution over lint screen.
3. Carefully wipe any accumulated lint off the cabinet high limit thermostat and thermistor, including perforated cover.
4. Clean lint and debris buildup from blower to maintain proper airflow.

## Quarterly

1. Use a vacuum to clean air vents on drive motors.
2. Use a vacuum to clean lint from rear limit thermostat cover.
3. Check and clean steam coils, if applicable.
4. Check flow of combustion and ventilation air.
5. Check belt tension and condition. Replace worn or cracked belts.
6. Clean the machine's top panel with mild detergent. Rinse with clean water.
7. **Models equipped with a fire suppression system:** Perform the fire suppression system maintenance test by pressing the test button in the control box.

## Bi-Annually

1. Check mounting hardware for any loose nuts, bolts or screws.
2. Check gas connections for leakage.
3. Check for loose electrical connections.
4. Check steam connections for looseness and leakage.
5. Check steam filter. Replace if dirty.
6. Remove all front panels and vacuum, including coin drop mechanisms.
7. Check cylinder and front panel seals.
8. Inspect cabinet and inner panels for any damage, replace or repair as needed.
9. Clean burner tubes and orifice area of any lint buildup.
10. **Machines equipped with a fire suppression system:** All inlet and outlet hoses should be checked for any visible signs of deterioration. Replace as necessary or every five years.
11. **Machines equipped with a heat exchanger kit:** Clean the inlet and outlet with a soft brush or clean by using hot water and, if needed, a mild detergent.

## Annually

1. Remove burner tubes.

2. Clean burner tubes using water and a brush.
3. Remove cylinder. Use a vacuum to clean lint from area around rear seal and idler assembly and check for wear.

## Fire Suppression System (Optional Equipment) Maintenance Test

**NOTE: Fire suppression system only available on gas and steam models.**

To ensure proper operation, the fire suppression system must be tested every three months. If the system test does not perform as indicated:

1. Discontinue use of the tumble dryer.
2. Refer to Troubleshooting Manual or contact a qualified service person.
3. Restore the fire suppression system to proper working order before using tumble dryer.

Create a maintenance record with a check box for pass, the date and a signature. Store this record in an area where it will not be damaged, but is easily accessible to person performing tests.

**NOTE: Failure to maintain the fire suppression system will void the tumble dryer warranty.**

**NOTE: The auxiliary output is activated during the fire suppression system maintenance test sequence. Consider this fact prior to testing the system every three months. (Example – If the external system uses the auxiliary output to call the fire department, inform the fire department before and after the fire suppression system maintenance test.)**

	<b>CAUTION</b>
<b>Clean up any water spilled during testing to avoid personal injury.</b>	
W487	

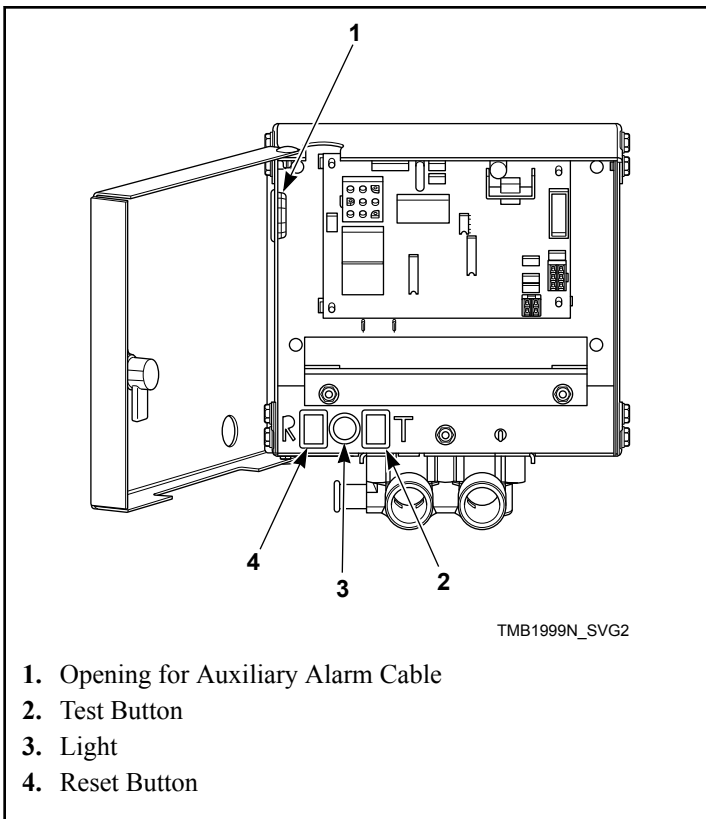

- 1. Opening for Auxiliary Alarm Cable
- 2. Test Button
- 3. Light
- 4. Reset Button

Figure 67

To perform the fire suppression system maintenance test:

1. If the auxiliary alarm output is connected to a separate alarm system, disconnect prior to performing the fire suppression system maintenance test.
2. Remove any lint from the lint compartment.
3. Ensure temperature sensors are free of lint.
4. Place a load of dry towels in the tumble dryer. Refer to *Table 32* for proper load size. Ensure the cylinder baffles are to the left and right of the spray manifold located at the center top of the cylinder.
5. Unlock the fire suppression system control box.
6. Press and hold the test button, verify the light is on, this should take approximately five seconds. Refer to *Figure 67*. After a one-second pause water should begin to spray into the cylinder.
7. After 15 seconds of water spray, press and hold the reset button until water spray is off and light is off. This should take approximately one second. Refer to *Figure 67* and *Figure 68*.
8. Immediately remove and weigh the load. Refer to *Table 32* for acceptable weight range. If less than minimum pounds indicated in *Table 32*, the fire suppression system has failed the maintenance test. Refer to the Troubleshooting Manual.

**IMPORTANT: If the fire suppression system failed the maintenance test, DO NOT operate the tumble dryer.**

	Dry Weight	Wet Weight	Minimum Weight
	lbs. [kg]	lbs. [kg]	lbs. [kg]
25	15 [9]	20-24 [9-11]	18 [8]
30	15 [9]	20-24 [9-11]	18 [8]
35	25 [11]	30-34 [14-15]	28 [13]
55	25 [11]	33-37 [15-17]	31 [14]

Table 32

9. Clean up any water on the floor.
10. Lock the fire suppression system control box.
11. If the separate alarm option is being used, reconnect the auxiliary alarm output.
12. Start the tumble dryer to dry the test load.
13. On maintenance record, check box if fire suppression system passed the test, date and sign record.

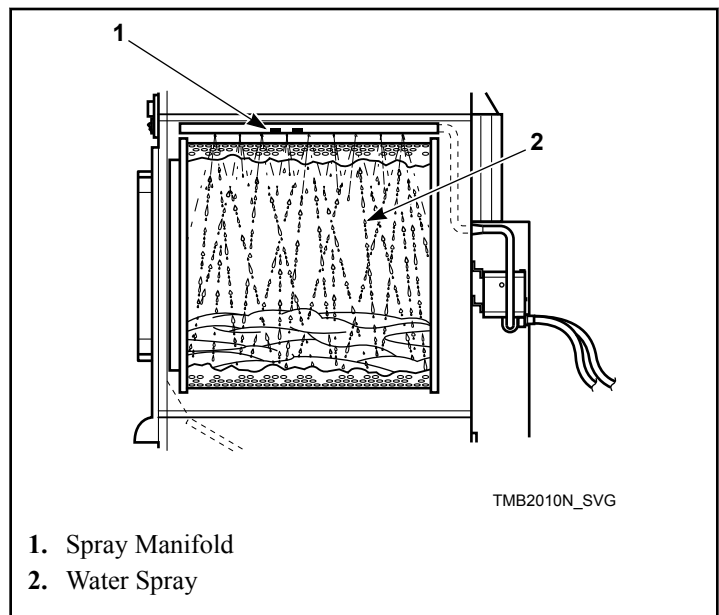

- 1. Spray Manifold
- 2. Water Spray

Figure 68



# Before You Call for Service

Won't Start	Won't Heat	Clothes Not Dry	Possible Reason – Corrective Actions
•			Insert correct coin(s) or valid card if applicable.
•			Close the loading door tightly.
•			Close lint panel tightly.
•			Press the PUSH-TO-START or START pad/button.
•			Be sure power cord is plugged all the way into the electrical outlet and hard or direct wire connections are tight.
•			Check the main fuse and circuit breaker.
•			Check fuses located in the machine.
	•		Insufficient airflow.
	•		Gas shut-off valve in OFF position.
	•		Are controls properly set?
	•		Broken drive belt. Call the service person.
	•	•	Tumble dryer is in Cool Down Mode.
	•	•	Lint screen clogged. Clean lint screen.
	•	•	Exhaust duct to outside is blocked. Clean out.

# Removing Tumble Dryer from Service

1. Turn off electrical supply external to machine.
2. Turn off electrical disconnect on machine.
3. Turn off gas supply external to machine.
4. Turn off manual gas shut-off valve on machine.
5. Turn off steam supply external to machine.
6. Remove all electric, gas and steam connections.

# Disposal of Unit

This appliance is marked according to the European directive 2002/96/EC on Waste Electrical and Electronic Equipment (WEEE).

This symbol on the product or on its packaging indicates that this product shall not be treated as household waste. Refer to *Figure 69*. Instead it shall be handed over to the applicable collection point for the recycling of electrical and electronic equipment. Ensuring this product is disposed of correctly will help prevent potential negative consequences for the environment and human health which could otherwise be caused by inappropriate waste handling of this product. The recycling of materials will help to conserve natural resources. For more detailed information about recycling of this product, please contact the local city office, household waste disposal service, or the source from which the product was purchased.

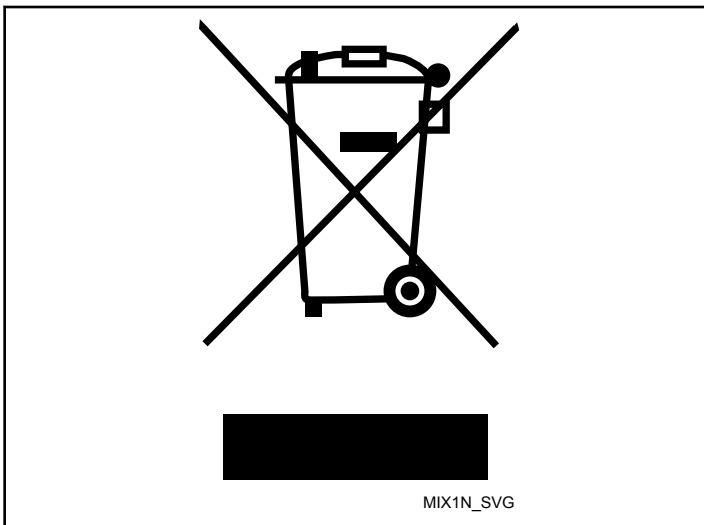



Figure 69

# China Restriction of hazardous substances (RoHS)

The Table of Hazardous Substances/Elements and their Content

As required by China's Management Methods for Restricted Use of Hazardous Substances in Electrical and Electronic Products

Hazardous substances						
Part Name	Lead (Pb)	Mercury (Hg)	Cadmium (Cd)	Hexavalent Chromium (CR[VI])	Polybrominated biphenyls (PBB)	Polybrominated diphenyl ethers (PBDE)
PCBs	X	O	O	O	O	O
Electromechanical Parts	O	O	O	O	O	O
Cables and Wires	O	O	O	O	O	O
Metal Parts	O	O	O	O	O	O
Plastic Parts	O	O	O	O	O	O
Batteries	O	O	O	O	O	O
Textile	O	O	O	O	O	O
Timing Belts	O	O	O	O	O	O
Insulation	O	O	O	O	O	O
Glass	O	O	O	O	O	O
Display	O	O	O	O	O	O
<p>This table is prepared in accordance with the provisions of SJ/T-11364.</p> <p>O: Indicates that the content of said hazardous substance in all of the homogenous materials in the component is within the limits required by GB/T 26572.</p> <p>X: Indicates that the content of said hazardous substance exceeds the limits required by GB/T 26572 in at least one homogenous material in the component.</p> <p><b>All parts named in this table with an "X" are in compliance with the European Union's RoHS Legislation.</b></p> <p><b>NOTE: The referenced Environmental Protection Use Period Marking was determined according to normal operating use conditions of the product such as temperature and humidity.</b></p>						
	This product under normal use, durable years of environmental protection is 15 years.					