

Washer-Extractors

Cabinet Freestanding

Refer to Page 2 for Model Identification

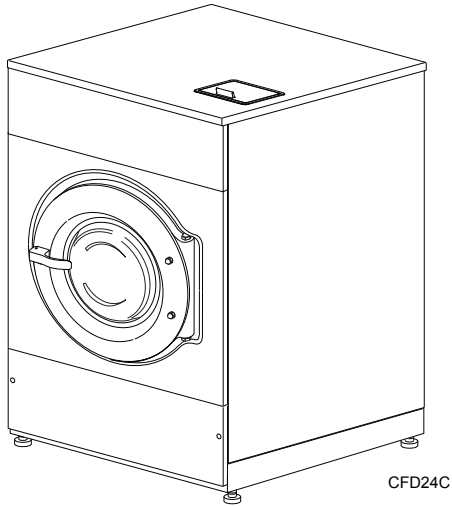

18, 25, 30 and 35 Models

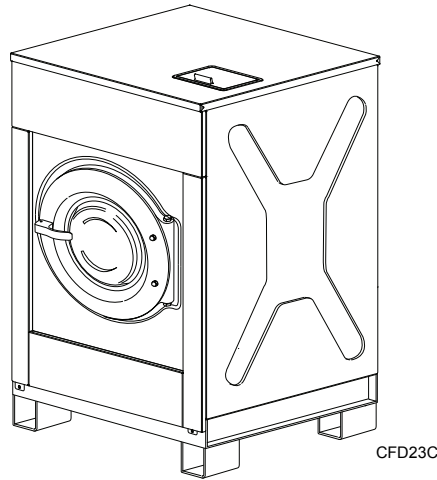

33, 40, 55 and 75 Models

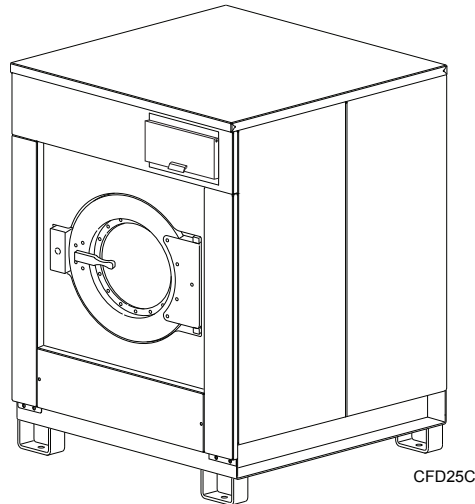

100, 135, 165 and 200 Models

Keep These Instructions for Future Reference.

(If this machine changes ownership, this manual must accompany machine.)



Table of Contents

Introduction	2
Model Identification	2
Nameplate Location.....	4
Replacement Parts	4
Customer Service.....	4
Safety Information	5
Explanation of Safety Messages.....	5
Important Safety Instructions	5
Safety Decals	7
Operator Safety	8
Operation	9
WE-8 Control Panel (OPL Models)	9
Load the Machine	10
Start a Program	10
Special Options in Run Mode.....	11
Advance Mode.....	11
Chemical Hold Feature	11
Stop the Machine	12
Error Messages	13
Operation	17
B-Control Panel (Coin-Operated Models).....	17
Summary of Major Features	17
Load the Machine	18
Start a Program	18
Maintenance	20
Daily	20
Weekly	21
Monthly.....	21
Yearly	22

© Copyright 2011, Alliance Laundry Systems LLC

All rights reserved. No part of the contents of this book may be reproduced or transmitted in any form or by any means without the expressed written consent of the publisher.

Introduction

Model Identification

Information in this manual is applicable to these models:

18	HX018PVQM7	NX018BVXA7	SX018BVPA7	SX18BVXM7	UX018PVQA7	UX18PVQA6
	HX018PVXM7	NX018BVXM7	SX018BVQA7	SX18PVPA7	UX018PVQM7	UX18PVQA7
	HX18PVQM6	NX18BVPA6	SX018BVXA7	SX18PVQM6	UX018PVXA7	UX18PVQM6
	HX18PVQM7	NX18BVPA7	SX018BVXM7	SX18PVQM7	UX018PVXM7	UX18PVQM7
	HX18PVQU6	NX18BVQA6	SX018PVPA7	SX18PVQU6	UX18PVNA6	UX18PVQU6
	HX18PVXM6	NX18BVQA7	SX018PVQM7	SX18PVXM6	UX18PVNA7	UX18PVXA6
	HX18PVXM7	NX18BVXA6	SX018PVXM7	SX18PVXM7	UX18PVNU6	UX18PVXA7
	HX18PVXU6	NX18BVXA7	SX18BVPA7	SX18PVXU6	UX18PVPA6	UX18PVXM6
	NX018BVPA7	NX18BVXM6	SX18BVQA7	UX018PVNA7	UX18PVPA7	UX18PVXM7
	NX018BVQA7	NX18BVXM7	SX18BVXA7	UX018PVPA7	UX18PVPU6	UX18PVXU6
25	HX025PVQM7	HX25PVXU6	SX25PVXM7	UX025PVXM7	UX25PVQA6	UX25PVXM6
	HX025PVXM7	SX025PVQM7	SX25PVXU6	UX25PVNA6	UX25PVQA7	UX25PVXM7
	HX25PVQM6	SX025PVXM7	UX025PVNA7	UX25PVNA7	UX25PVQM6	UX25PVXU6
	HX25PVQM7	SX25PVQM6	UX025PVPA7	UX25PVNU6	UX25PVQM7	
	HX25PVQU6	SX25PVQM7	UX025PVQA7	UX25PVPA6	UX25PVQU6	
	HX25PVXM6	SX25PVQU6	UX025PVQM7	UX25PVPA7	UX25PVXA6	
	HX25PVXM7	SX25PVXM6	UX025PVXA7	UX25PVPU6	UX25PVXA7	
30	NX030BVPA7	NX30BVPA6	NX30BVXA6	SX030BVPA7	SX30BVPA7	
	NX030BVQA7	NX30BVPA7	NX30BVXA7	SX030BVQA7	SX30BVQA7	
	NX030BVXA7	NX30BVQA6	NX30BVXM6	SX030BVXA7	SX30BVXA7	
	NX030BVXM7	NX30BVQA7	NX30BVXM7	SX030BVXM7	SX30BVXM7	
33	SX33BVPA7	SX33BVXA7	UX33PVNA7	UX33PVQA7	UX33PVXA7	UX33PVXM7
	SX33BVQA7	SX33BVXM7	UX33PVPA7	UX33PVQM7		
35	HX035PVQM7	HX35PVXU6	SX35PVQU6	UX035PVQM7	UX35PVQA6	UX35PVXM7
	HX035PVXM7	SX035PVNM7	SX35PVXM6	UX035PVXA7	UX35PVQA7	UX35PVNU6
	HX35PVQM6	SX035PVQM7	SX35PVXM7	UX035PVXM7	UX35PVQM6	UX35PVPU6
	HX35PVQM7	SX035PVXM7	SX35PVXU6	UX35PVNA6	UX35PVQM7	UX35PVQU6
	HX35PVQU6	SX35PVNM7	UX035PVNA7	UX35PVNA7	UX35PVXA6	UX35PVXU6
	HX35PVXM6	SX35PVQM6	UX035PVPA7	UX35PVPA6	UX35PVXA7	
	HX35PVXM7	SX35PVQM7	UX035PVQA7	UX35PVPA7	UX35PVXM6	
40	SX40BVPA7	SX40BVXA7	UX40PVNA7	UX40PVQA7	UX40PVXA7	
	SX40BVQA7	SX40BVXM7	UX40PVPA7	UX40PVQM7	UX40PVXM7	
55	HX055PVNU7	HX55PVQU7	SX055PVXU7	SX55PVQU7	UX055PVXF7	UX55PVQU6
	HX055PVQU7	HX55PVXU6	SX55PVNU6	SX55PVXU6	UX055PVXU7	UX55PVQU7
	HX055PVXU7	HX55PVXU7	SX55PVNU7	SX55PVXU7	UX55PVNU6	UX55PVXF6
	HX55PVNU6	SX055PVNU7	SX55PVPU6	UX055PVNU7	UX55PVNU7	UX55PVXF7
	HX55PVNU7	SX055PVPU7	SX55PVPU7	UX055PVPU7	UX55PVPU6	UX55PVXU6
	HX55PVQU6	SX055PVQU7	SX55PVQU6	UX055PVQU7	UX55PVPU7	UX55PVXU7
75	HX075PVNU7	HX75PVPU7	SX075PVQU7	SX75PVQU7	UX75PVNU7	
	HX075PVPU7	HX75PVQU6	SX75PVNU6	UX075PVNU7	UX75PVPU6	
	HX075PVQU7	HX75PVQU7	SX75PVNU7	UX075PVPU7	UX75PVPU7	
	HX75PVNU6	SX075PVNU7	SX75PVPU7	UX075PVQU7	UX75PVQU6	
	HX75PVNU7	SX075PVPU7	SX75PVQU6	UX75PVNU6	UX75PVQU7	

(continued)

(continued)

100	HX100PVNU6	HX100PVQU6	SX100PVNU7	SX100PVQU7	UX100PVPU6	UX100PVQU7
	HX100PVNU7	HX100PVQU7	SX100PVPU7	UX100PVNU6	UX100PVPU7	
	HX100PVPU7	SX100PVNU6	SX100PVQU6	UX100PVNU7	UX100PVQU6	
135	HX135PVNU6	HX135PVQU6	SX135PVNU7	SX135PVPU7	UX135PVPU6	UX135PVQU7
	HX135PVNU7	HX135PVQU7	SX135PVQU6	UX135PVNU6	UX135PVPU7	
	HX135PVPU7	SX135PVNU6	SX135PVQU7	UX135PVNU7	UX135PVQU6	
165	HX165PVNU6	HX165PVQU6	SX165PVNU7	SX165PVQU7	UX165PVPU6	UX165PVQU7
	HX165PVNU7	HX165PVQU7	SX165PVPU7	UX165PVNU6	UX165PVPU7	
	HX165PVPU7	SX165PVNU6	SX165PVQU6	UX165PVNU7	UX165PVQU6	
200	HX200PVNU7	HX200PVQU7	SX200PVPU7	UX200PVNU7	UX200PVQU7	
	HX200PVPU7	SX200PVNU7	SX200PVQU7	UX200PVPU7		

Introduction

Nameplate Location

The nameplate is located at the rear of the machine. Always provide the machine's serial number and model number when ordering parts or when seeking technical assistance. Refer to *Figure 1*.

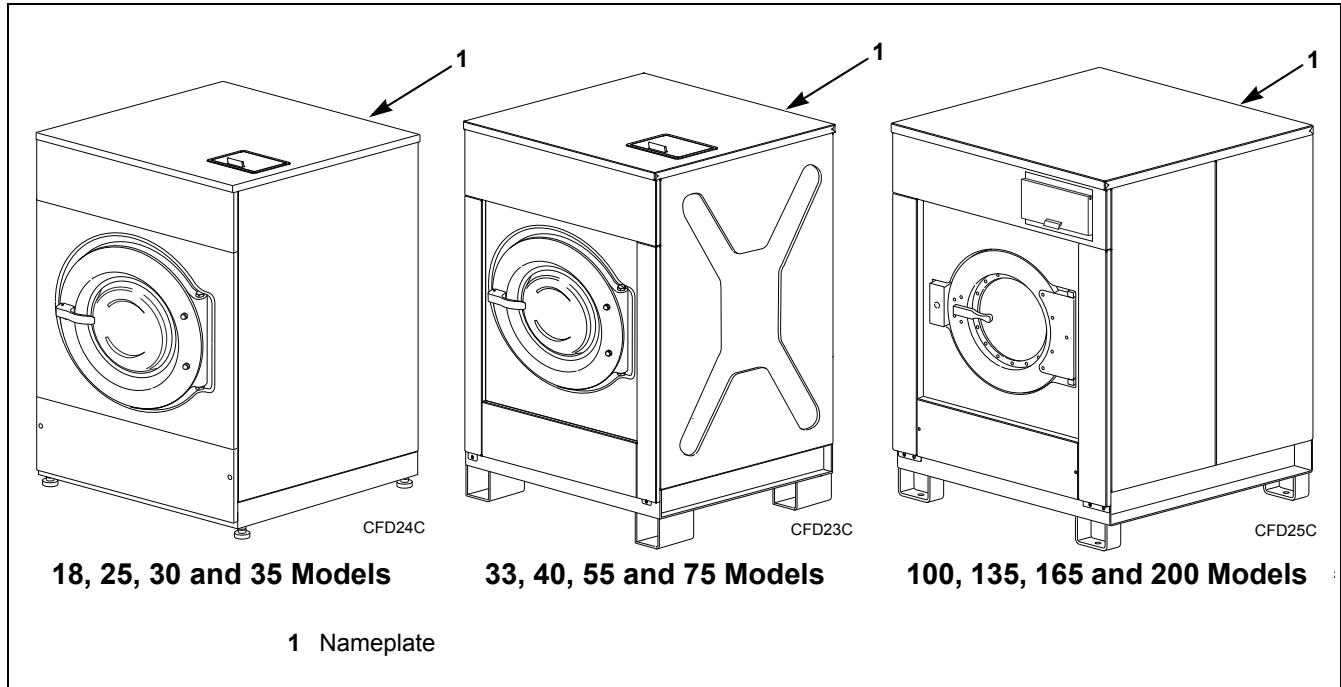

Figure 1

Replacement Parts

If literature or replacement parts are required, contact the source from which the machine was purchased or contact Alliance Laundry Systems at (920) 748-3950 for the name and address of the nearest authorized parts distributor.

Customer Service

For technical assistance, contact your local distributor or contact:

Alliance Laundry Systems
Shepard Street
P.O. Box 990
Ripon, Wisconsin 54971-0990
U.S.A.

www.coinlaundry.com
Phone: +1 (920) 748-3121
+32 56 41 20 54
Wevelgem, Belgium

Safety Information

Explanation of Safety Messages

Precautionary statements (“DANGER,” “WARNING,” and “CAUTION”), followed by specific instructions, are found in this manual and on machine decals. These precautions are intended for the personal safety of the operator, user, servicer, and those maintaining the machine.

	DANGER
DANGER indicates the presence of a hazard that will cause severe personal injury, death, or substantial property damage if the danger is ignored.	

	WARNING
WARNING indicates the presence of a hazard that can cause severe personal injury, death, or substantial property damage if the warning is ignored.	

	CAUTION
CAUTION indicates the presence of a hazard that will or can cause minor personal injury or property damage if the caution is ignored.	

Additional precautionary statements (“IMPORTANT” and “NOTE”) are followed by specific instructions.

IMPORTANT: The word “IMPORTANT” is used to inform the reader of specific procedures where minor machine damage will occur if the procedure is not followed.

NOTE: The word “NOTE” is used to communicate installation, operation, maintenance or servicing information that is important but not hazard related.

Important Safety Instructions

	WARNING
To reduce the risk of fire, electric shock, serious injury or death to persons when using your washer, follow these basic precautions:	
W023	

1. Read all instructions before using the washer.
2. Install the washer according the INSTALLATION instructions. Refer to the EARTHING (grounding) instructions in the INSTALLATION manual for the proper earthing (grounding) of the washer. All connections for water, drain, electrical power and earthing (grounding) must comply with local codes and be made by licensed personnel when required. It is recommended that the machine be installed by qualified technicians.
3. Do not install or store the washer where it will be exposed to water and/or weather.
4. To prevent fire and explosion, keep the area around machine free from flammable and combustible products. Do not add the following substances or textiles containing traces of the following substances to the wash water: gasoline, kerosene, waxes, cooking oils, vegetable oils, machine oils, dry-cleaning solvents, flammable chemicals, thinners, or other flammable or explosive substances. These substances give off vapors that could ignite, explode or cause the fabric to catch fire by itself.
5. Under certain conditions, hydrogen gas may be produced in a hot water system that has not been used for two weeks or more. HYDROGEN GAS IS EXPLOSIVE. If the hot water system has not been used for such a period, before using a washing machine or combination washer-dryer, turn on all hot water faucets and let the water flow from each for several minutes. This will release any accumulated hydrogen gas. The gas is flammable, do not smoke or use an open flame during this time.
6. To reduce the risk of an electric shock or fire, DO NOT use an extension cord or an adapter to connect the washer to the electrical power source.

Safety Information

7. Do not allow children to play on or in the washer. Close supervision of children is necessary when the washer is used near children. This appliance is not intended for use by young children or infirm persons without supervision. Young children should be supervised to ensure that they do not play with the appliance. This is a safety rule for all appliances.
8. DO NOT reach and/or climb into the tub or onto the washer, ESPECIALLY if the wash drum is moving. This is an imminently hazardous situation that, if not avoided, will cause severe personal injury or death.
9. Never operate the washer with any guards, panels and/or parts removed or broken. DO NOT bypass any safety devices or tamper with the controls.
10. Use washer only for its intended purpose, washing textiles. Never wash machine parts or automotive parts in the machine. This could result in serious damage to the basket or tub.
11. Use only low-sudsing, no-foaming types of commercial detergent. Be aware that hazardous chemicals may be present. Wear hand and eye protection when adding detergents and chemicals. Always read and follow manufacturer's instructions on packages of laundry and cleaning aids. Heed all warnings or precautions. To reduce the risk of poisoning or chemical burns, keep them out of the reach of children at all times (preferably in a locked cabinet).
12. Do not use fabric softeners or products to eliminate static unless recommended by the manufacturer of the fabric softener or product.
13. Always follow the fabric care instructions supplied by the textile manufacturer.
14. Loading door MUST BE CLOSED any time the washer is to fill, tumble or spin. DO NOT bypass the loading door switch by permitting the washer to operate with the loading door open. Do not attempt to open the door until the washer has drained and all moving parts have stopped.
15. Be aware that hot water is used to flush the supply dispenser. Avoid opening the dispenser lid while the machine is running.
16. Do not attach anything to the supply dispenser's nozzles, if applicable. The air gap must be maintained.
17. Do not operate the machine without the water reuse plug or water reuse system in place, if applicable.
18. Be sure water connections have a shut-off valve and that fill hose connections are tight. CLOSE the shut-off valves at the end of each wash day.
19. Keep washer in good condition. Bumping or dropping the washer can damage safety features. If this occurs, have washer checked by a qualified service person.
20. DANGER: Before inspecting or servicing machine, power supply must be turned OFF. The servicer needs to wait for at least 10 minutes after turning the power OFF and needs to check for residual voltage with a voltage meter. The inverter capacitor or EMC filter remains charged with high voltage for some time after powering OFF. This is an imminently hazardous situation that, if not avoided, will cause severe personal injury or death.
21. Do not repair or replace any part of the washer, or attempt any servicing unless specifically recommended in the user-maintenance instructions or in published user-repair instructions that the user understands and has the skills to carry out. ALWAYS disconnect the washer from electrical, power and water supplies before attempting any service.
22. Disconnect the power cord by grasping the plug, not the cord. Replace worn power cords and/or loose plugs. If the supply cord is damaged, it must be replaced by a special cord or assembly available from the service agent.
23. Before the washer is removed from service or discarded, remove the door to the washing compartment.
24. Failure to install, maintain, and/or operate this washer according to the manufacturer's instructions may result in conditions which can produce bodily injury and/or property damage.

NOTE: The WARNINGS and IMPORTANT SAFETY INSTRUCTIONS appearing in this manual are not meant to cover all possible conditions and situations that may occur. Common sense, caution and care must be exercised when installing, maintaining, or operating the washer.

Always contact your dealer, distributor, service agent or the manufacturer on any problems or conditions you do not understand.

	WARNING
<p>This machine must be installed, adjusted, and serviced by qualified electrical maintenance personnel familiar with the construction and operation of this type of machinery. They must also be familiar with the potential hazards involved. Failure to observe this warning may result in personal injury and/or equipment damage, and may void the warranty.</p> <p style="text-align: right;">SW004</p>	

IMPORTANT: Ensure that the recommended clearances for inspection and maintenance are provided. Never allow the inspection and maintenance space to be blocked.

	WARNING
<p>Never touch internal or external steam pipes, connections, or components. These surfaces can be extremely hot and will cause severe burns. The steam must be turned off and the pipe, connections, and components allowed to cool before the pipe can be touched.</p> <p style="text-align: right;">SW014</p>	

Safety Decals

Safety decals appear at crucial locations on the machine. Failure to maintain legible safety decals could result in injury to the operator or service technician.

Use manufacturer-authorized spare parts to avoid safety hazards.

Safety Information

Operator Safety

	WARNING
NEVER insert hands or objects into basket until it has completely stopped. Doing so could result in serious injury.	
<small>SW012</small>	

The following maintenance checks must be performed daily:

1. Verify that all warning signs are present and legible, replace as necessary.
2. Check door interlock before starting operation of the machine:
 - a. Attempt to start the machine with the door open. The machine should not start.
 - b. Close the door without locking it and attempt to start the machine. The machine should not start.
 - c. Attempt to open the door while a cycle is in progress. The door should not open.

If the door lock and interlock are not functioning properly, call a service technician.

3. Do not attempt to operate the machine if any of the following conditions are present:
 - a. The door does not remain securely locked during the entire cycle.
 - b. Excessively high water level is evident.
 - c. Machine is not connected to a properly grounded circuit.

Do not bypass any safety devices in the machine.

	WARNING
Operating the machine with severe out-of-balance loads could result in personal injury and serious equipment damage.	
<small>W728</small>	

Operation

WE-8 Control Panel (OPL Models)

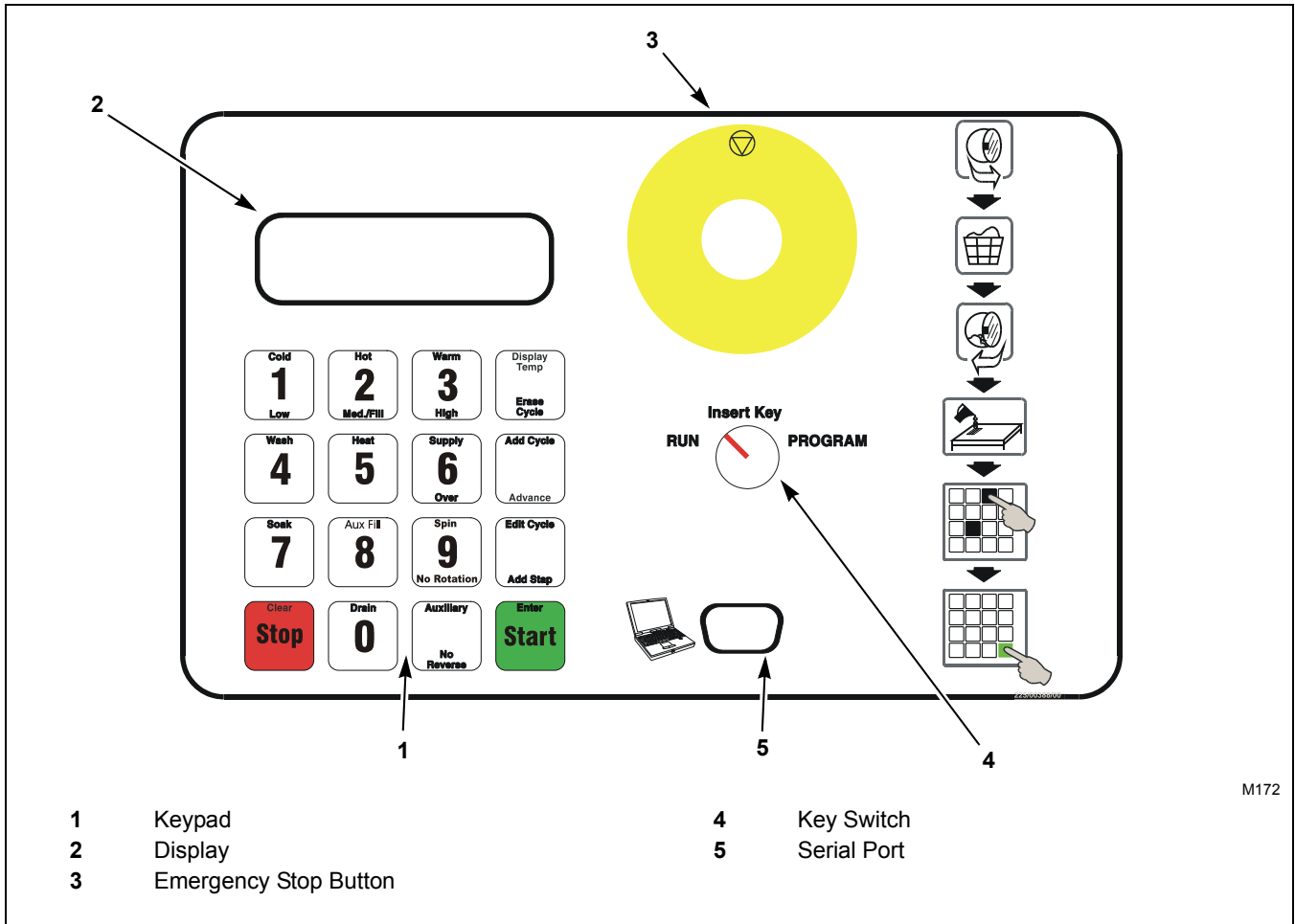

M172

Figure 2

Operation

Load the Machine

For 18 - 75 pound models:

1. Pull the door handle towards you to open the door. Some models may have a door handle with a button that must be pressed.
2. Load the drum to the specified capacity.
3. Close the door by pushing the door handle towards the machine.

Start a Program

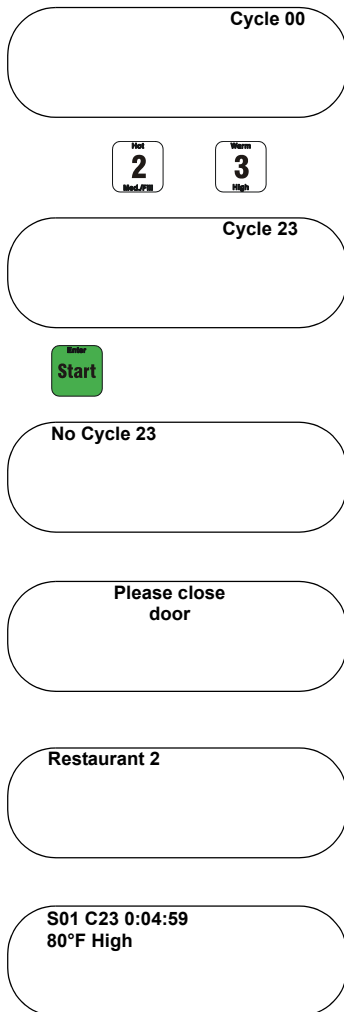

For 100 - 200 pound models:

1. Push on the doorlock system to open the door.
2. Load the drum to the specified capacity.
3. Close the door by pushing the door handle towards the machine.

1. After powering up the control, "Cycle 00" will show on the display.
2. Press the desired program number (example: program 23).
 - a. The display will show the cycle (example: "Cycle 23").
3. Press "Start" to run the program.
 - a. If the program does not exist, the display will show "No Cycle 23". See program mode to create a program.
 - b. If the door is not closed, the display will show "Please close door". The program will start once the door is closed.
 - c. If the door is closed and the program exists, the program will start. The name of the program will show on the display for 2 seconds and the machine will start.

When the machine is started, the display will show the following information:

S01: Step 1

C23: Program number 23

0:04:59: The time of step 1. This will count down to 0 and then go to step 2 (S02).

80°F: The temperature of the bath that is programmed.

Special Options in Run Mode

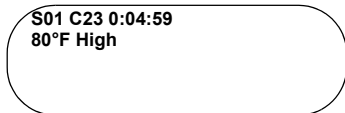
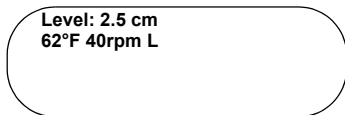
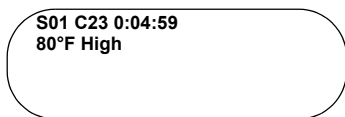

High: The water level in step 1 that is programmed.

1. While the machine is running, press the “Display Temp” button.

Level: 2.5 cm: Water level in the bath. If the machine is filling with water, this value will increase. If the machine is draining, this value will decrease.

62°F: The water temperature.

40 rpm: The measured rpm of the drum.

L: Rotation direction of the drum
L (left), R (right)

2. Press the “Display Temp” button to go back.

Advance Mode

Press the “Advance” button to proceed to the next step in the program.

Chemical Hold Feature

Chemical supply injection can be paused. Refer to section *Setup of the Chemical Hold Feature* in Programming manual.

Operation

Stop the Machine



1. Press the “Stop” button.

If there is water in the machine, the display will show “Waterlevel xx.x cm” while the machine is draining the water.

If the machine is spinning, the display will show “Coast down”.

When the water is out and the drum has stopped moving, the display will flash between “Please open door” and “Done cycle 23” until the door is open.

Error Messages

Door error

Door Error

If the door is closed after start, the control will try to lock the door. If the door will not lock, “Door error” will display.

Possible Faults:

- Wiring is not connected properly.
- Coil to lock the door has failed.
- Door lock has a mechanical problem.

Didn't fill within time

Fill Alarm

If machine does not reach programmed water level within time programmed for step, a fill alarm occurs. Machine will continue filling and agitating, while sounding beeper and flashing “Didn't fill within time” on display.

Enter to retry
Clear to stop

Condition will continue for up to two (2) minutes. If programmed water level is reached before two minute fill alarm time ends, condition ends, and machine resumes operation.

If Enter (START) key is pressed during fill alarm, condition will end and step will start over. If programmed water level is not reached within programmed step time, fill alarm will occur again.

Done Cycle CC

If Clear (STOP) key is pressed while fill alarm is in effect, cycle will end, and door will unlock.

Please open door

If no action is taken, and fill level is not reached within two (2) minute alarm time limit, cycle will end and door can be unlocked (provided no water level is sensed). Whenever a fill alarm occurs during a cycle, display will repeat the messages shown on the left at end of stop routine, before door is opened, to indicate alarm condition occurred in cycle.

Didn't fill within time

During step N

(CC = cycle number;
N = step number in which the alarm occurred).

Fill Alarm (Continued)

Possible Faults:

- Wiring is disconnected.
- Broken inlet valve.
- Problem with water supply.
- Inlet valves are blocked by dirt.
- The water pressure hose is broken or not connected properly.

Didn't drain
within time

Enter to retry
Clear to stop

Done Cycle CC

Please open door

Didn't drain
within time

During step N

(CC = cycle number;
N = step number in which the
alarm occurred).

Drain Alarm

If drain step is NOT followed by a spin and if machine does not empty within the time programmed for drain step, a drain alarm occurs. Display will read "Didn't drain within time."

During drain alarm, beeper sounds on and off, and machine continues attempting to drain. If machine does not empty, condition continues.

If Enter (START) key is pressed, drain alarm ends, and drain step starts over at beginning. If machine has not emptied when drain step time expires, alarm occurs again.

If Clear (STOP) key is pressed while drain alarm is in effect, display shows water level (inches or centimeters), but otherwise takes no new action since machine has not emptied.

When cycle ends, display will briefly repeat the messages shown on the left until door is opened (to indicate that an alarm condition occurred in the cycle).

If machine drains during a spin step prior to accelerating into high speed and if machine has not emptied within approximately two (2) minutes of starting drain procedure, a drain alarm occurs. There is no rotation during this alarm; messages displayed are identical to drain alarm during a drain step not followed by a spin.

If Enter (START) key is pressed during drain alarm in a spin step, the alarm will stop and the spin step will start over. Machine will rotate at wash speed forward, then transition to distribution speed.

After drain begins (i.e. drain open, pumping begins), if two (2) additional minutes elapse, alarm occurs again.

Temperature sensor error

Temperature Sensor Error

The temperature was never reached in this cycle, indicating a problem with heating, and the control shows “Temperature sensor error”.

Possible Faults:

- Bad temperature probe.
- Wiring to electrical or steam heating relay has failed.
- Electrical heating elements or steam valve is broken.

NOTE: If the cycle aborted, it may be due to a temperature sensor error.

Rotation sensor error

Rotation Sensor Error

The control did not sense any pulses or the control sensed wrong pulses from the RPM Sensor.

Possible Faults:

- Broken RPM Sensor.
- Distance from RPM Sensor to pulley is too large (greater than 2 mm).
- Bad motor.
- Broken V-belt.
- Problems with the inverter.
- Wiring disconnected.

Speed detection error

Speed Detection Error

An error occurred at the end of a spin stop or during coast down, where the RPM Sensor suddenly failed to give output pulses.

Possible Faults:

- Broken RPM Sensor.
- RPM Sensor dislocated (distance from RPM Sensor to pulley is greater than 2 mm).
- Broken V-belt.
- Wiring disconnected.

Operation

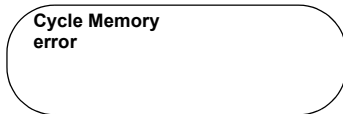

Cycle Memory Error

The cycle memory is corrupt and contains unknown information.

Possible fault:

- Unknown component found in wash cycles.

Operation

B-Control Panel (Coin-Operated Models)

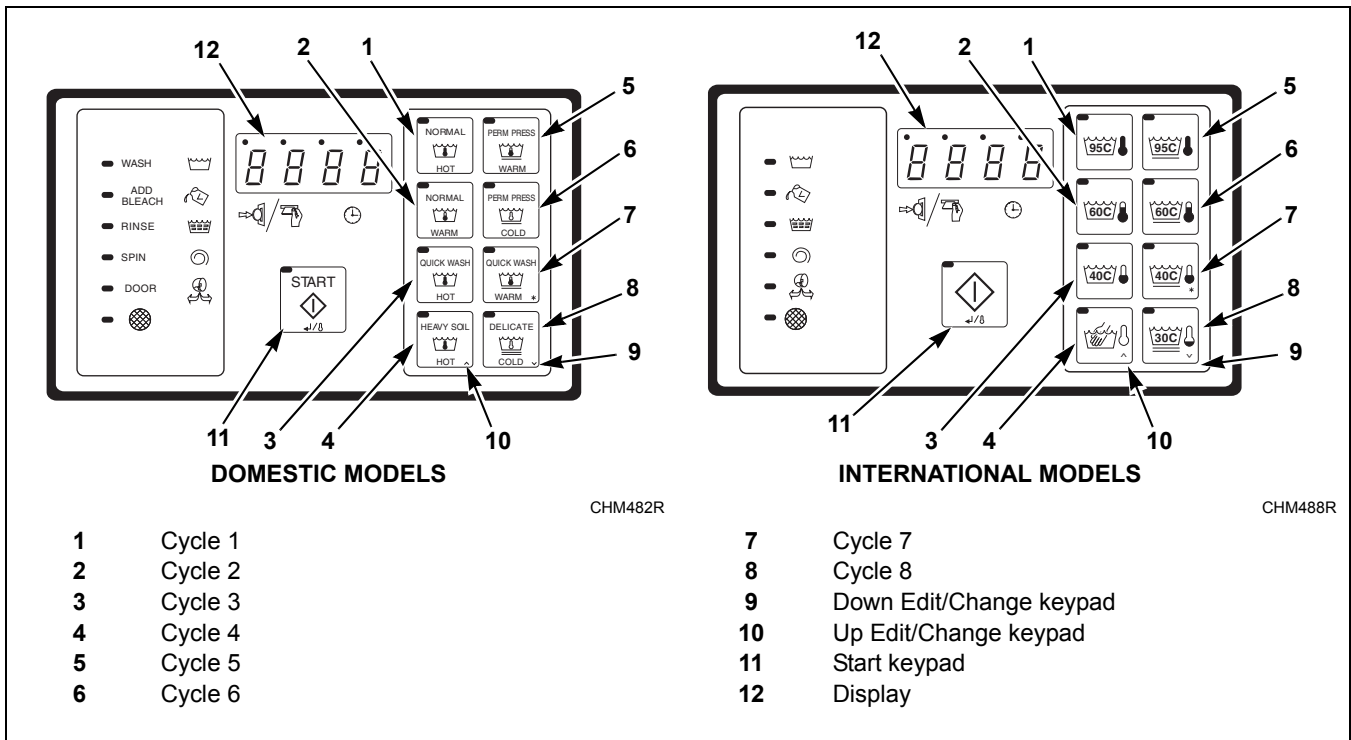

Figure 3

Summary of Major Features

LED for Machine Functions	LED lights inform operator which machine function is active. DOOR LED lights to inform operator that the door can be opened or should be closed. The circle LED is unavailable.
Main LED display	4 digit LED display counts down vend amount and cycle time.
Cycle selection keypads	Eight (8) cycle select keypads with LED indicator to show selected cycle. LED lights will flash to prompt user to press a keypad.
START keypad	Press to start a cycle after payment is made. LED light will flash to prompt user to press keypad.
Payment Methods	Coin – Single denomination coin drop meter, prepped for after market coin drop
Fill Temperatures	Cold, Hot, Warm
Supplies	Three (3) – Supply 1 (Compartment A), 2 (Compartment B), and 3 (Compartment C)
Agitation Types	Normal or Gentle
Drain Options	Normally open gravity drain
Automatic Unlock after Power Failure During Cycle	Standard

Table 1

Operation

Load the Machine

1. Turn on main power at its source (circuit breaker).
2. Pull the door handle towards you to open the door. Some models may have a door handle with a button that must be pressed.
3. Load to capacity whenever possible. **DO NOT OVERLOAD.** Refer to *Figure 4*.

NOTE: Underloading can cause out-of-balance conditions that can shorten machine life.

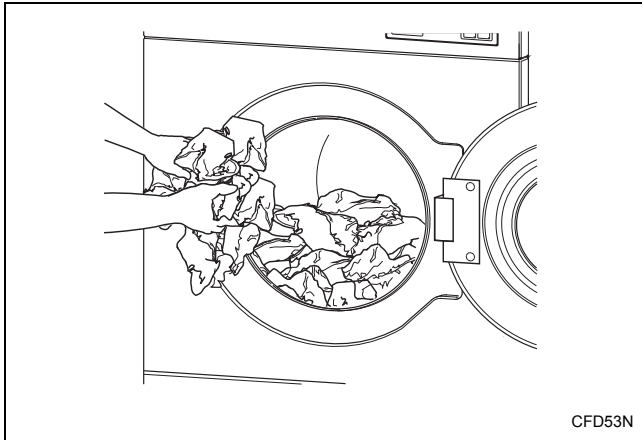

Figure 4

4. Close door by pushing door handle towards machine.

Start a Program

5. The default wash cycle will display.

NOTE: Perm Press Cold is the default cycle for coin models if none is selected.

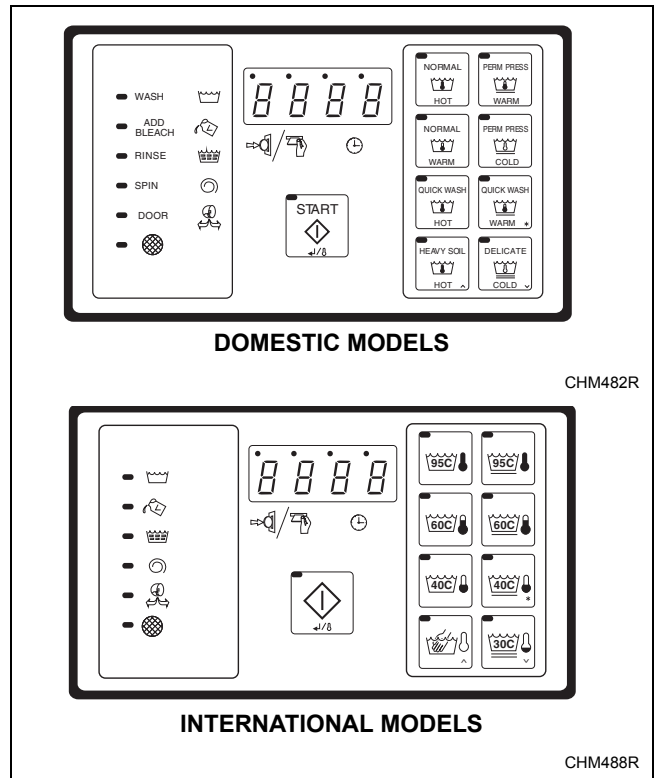

Figure 5

6. If desired, select a different cycle at this point or after satisfying vend. The LED indicator for that cycle will light.

7. Add liquid and/or powder supplies to supply dispenser. Refer to *Figure 6*.
 - a. Add detergent to compartment A.
 - b. Add softener to compartment C.

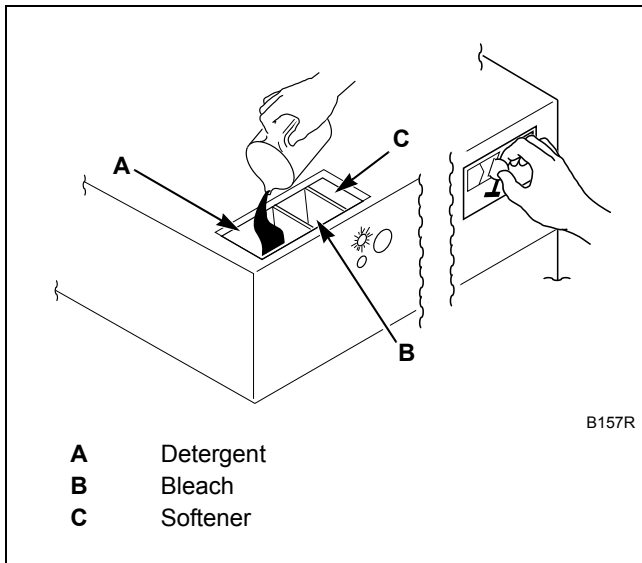



Figure 6

8. Add coins to machine. As each coin is added, the vend counts down to the amount remaining. Refer to *Figure 6*.
9. **When applicable**, add bleach to compartment B when the ADD BLEACH LED is lit. Refer to *Figure 6*.
10. Press the desired wash cycle keypad.
11. Press the START keypad and the active cycle remains the chosen wash cycle.
12. When cycle is complete, display shows “donE”.

Maintenance

Routine maintenance maximizes operating efficiency and minimizes downtime. The maintenance procedures described below will prolong the life of the machine and help prevent accidents.

	CAUTION
<p>Replace all panels that are removed to perform service and maintenance procedures. Do not operate the machine with missing guards or with broken or missing parts. Do not bypass any safety devices.</p>	
<small>SW019</small>	

Daily

Beginning of day

1. Inspect water inlet valve hose connections on the back of the machine for leaks.
2. Inspect steam hose connections for leaks, where applicable.
3. Check door interlock before starting operation.
 - a. Attempt to start the machine with the door open. The machine should not start.
 - b. Close the door without locking it and attempt to start the machine. The machine should not start.
 - c. Attempt to open the door while a cycle is in progress. The door should not open.

IMPORTANT: If the door lock and interlock are not functioning properly, call a qualified service technician.

End of day

1. Clean the fan of the AC drive box.
2. Clean the entire cabinet of the machine regularly and remove all traces of soap, etc.
3. Remove all detergent residue in the soap dispenser with hot water.
4. Clean the door gasket and remove all detergents and other products.
5. Shut off the main water, steam and power connections at the end of each day. Do not change the setting of the water inlet taps on boiler fed machines once these have been installed.
6. Leave the door and the soap dispenser open after use to ventilate the machine.

NOTE: Unload the machine promptly after each completed cycle to prevent moisture buildup. Leave loading door open at the end of each completed cycle to allow moisture to evaporate.

7. Check the alignment of the out-of-balance switch to make sure it is centered in the tilt detector plate cut-out.

Weekly

1. Check the machine for leaks.
 - a. Start an unloaded cycle to fill the machine.
 - b. Verify that door and door gasket do not leak.
 - c. Verify that the drain valve is operating. If water does not leak out during the prewash segment, drain valve is closed and functioning properly.

Monthly

NOTE: Disconnect power to the machine at its source before performing the monthly maintenance procedures.

1. Clean the AC drive box.
 - a. Remove the AC drive box cover.
 - b. Blow the fins clean using compressed air at a pressure of 60-90 psi or by using canned compressed air. Use care to avoid damaging cooling fan or other components.
2. Inspect the V-belts.
 - a. Check V-belts for uneven wear and frayed edges.
 - b. Verify that V-belts are properly aligned by checking pulley alignment. Place a straightedge across both pulley faces. The straightedge should make contact with the pulleys in four places.

Maintenance

3. Remove back panel and check overflow hose and drain hose for leaks.
4. Clean inlet hose filter screen:
 - a. Turn water off and allow valve to cool, if necessary.
 - b. Unscrew inlet hose and remove filter screen.
 - c. Clean with soapy water, rinse and reinstall. Replace if worn or damaged.
5. Check the supply dispenser hoses for leaks.
6. Use compressed air to clean lint from motor.
7. Clean interior of machine, both basket and shell, by wiping with a water-soaked sponge or cloth.
8. Use compressed air to ensure that all electrical components are free of moisture and dust.
9. Verify that insulation is intact on all external wiring and that all connections are secure. If bare wire is evident, call a qualified service technician.
10. If necessary, tighten the bearing housing's mounting bolts.
11. If necessary, tighten the shock absorber's mounting bolts.

Yearly

1. Replace the automatic lubricator (only for 75-200 pound machine). Failure to do so could void the warranty.
2. Check if the machine is working properly. If you see or hear any abnormal function on the machine, call a qualified service technician.