

QUANTUM® PLATINUM COIN DROP INSTALLED, PREP FOR COIN, PREP FOR CARD COMMERCIAL TOP LOAD WASHER PEAK PERFORMANCE

Built for Reliable Performance

Speed Queen's two-speed top load washer, defined by its simplicity and its performance, provides everything you need to get the job done – and nothing you don't. Speed Queen's top load washer combines heavy-duty construction with reliable operation proven to stand the test of time. Speed Queen washers provide maximum energy efficiency and long-lasting performance.

- Graphical display screen with animated and multi-language instructions
- Premium cycle upgrade prompts
- Extract speed of 710 RPM spins clothes out drier
- Strong Box security meter case
- Advanced suspension system
- Cycle programming flexibility
- User instructions are displayed in language selected
- Durable stainless steel tub standard
- 2.83 cu. ft. (80.14 liters) wash capacity
- Large capacity coin box standard
- Wash Alert™ capability

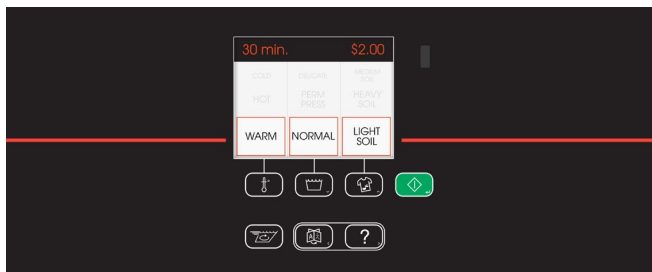

Quantum® Platinum Controls offer residents unparalleled flexibility. The full-color, multi-language display makes operation intuitive. Your residents have the ability to tailor wash cycles to their specific needs with a special “Speed Cycle” and other premium cycle upgrades. Management is simplified with advanced analytics and on-screen diagnostics to alert your laundry service provider to potential problems, minimizing downtime.



SPECIFICATIONS

COMMERCIAL TOP LOAD WASHER PEAK PERFORMANCE

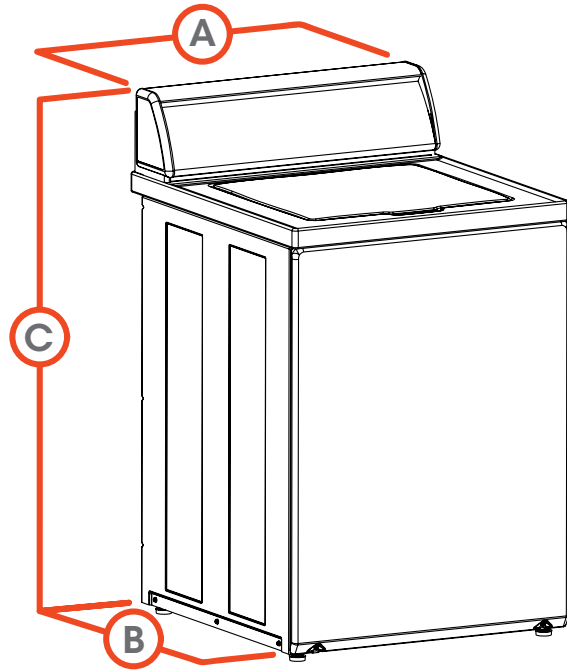
MODEL - see below for all models and activation available	
CONTROL OPTION	Quantum Platinum
COLOR	White
CAPACITY - lb (kg)	14 (6.4)
OVERALL WIDTH - in (mm)	25.63 (651)
OVERALL DEPTH - in (mm)	28 (711)
OVERALL HEIGHT - in (mm)	43 (1092)
CYLINDER VOLUME - cu. ft. (liters)	2.83 (80.14)
SPIN SPEED G-FORCE (RPM)	150 (710)
MOTOR SIZE - HP (kw)	0.5 (0.37)
WATER CONSUMPTION PER CYCLE - g (liter)	24.9 (94.3)
IWF (WATER FACTOR) - gal/ft ³ (liters/liter/cycle)	8.8 (1.18)
MEF ₂ (Modified Energy Factor) ft ³ /kWh/cycle (Liters/kWh/cycle)	1.35 (38.2)
AVAILABLE WATER TEMPERATURES	Hot, Warm, Cold
AVAILABLE CYCLES	Delicate, Perm Press, Normal, Heavy Soil, Medium Soil, Light Soil, Speed Cycle
CYCLE SELECTIONS	27 +
ELECTRICAL REQUIREMENTS (v/Hz/Ph-Amp)	120/60/1 - 15 Amp
WATER PRESSURE - p.s.i. (bar)	20-120 (1.4/8.3)
DRAIN	Pump
CYLINDER FINISH	Stainless Steel
NET WEIGHT - lb (kg)	206 (93.4)
SHIPPING WEIGHT - lb (kg)	218 (98.8)
SHIPPING DIMENSIONS APPROX. - in (mm)	Width 28 (711)
	Depth 30 (762)
	Height 45 (1143)
AGENCY APPROVALS	cULus



A.	OVERALL WIDTH - in (mm)	25.625 (651)
B.	OVERALL DEPTH - in (mm)	28 (711)
C.	OVERALL HEIGHT - in (mm)	43 (1092)

MODELS	ACTIVATION
SWNDC2HP115TW02 SWNYC2HP115TW02*	Coin Drop Installed 
SWNDX2HP115TW02	Prep for Coin 
SWNDY2HP115TW01 SWNYY2HP115TW01*	Prep for Card 

*Wireless Network Board Factory Installed

For the most accurate information, the installation guide should be used for all design and construction purposes. Due to continuous product improvements, design and specifications subject to change without notice. The quality management system of Alliance Laundry Systems' Ripon facility has been registered to ISO 9001:2000.



by Alliance Laundry Systems

speedqueencommercial.com/multihousing

AM18-0008 • ©2018 Alliance Laundry Systems LLC