

# SPEED QUEEN MULTI-HOUSING

QUANTUM® PLATINUM COIN DROP INSTALLED, PREP FOR COIN, PREP FOR CARD

## COMMERCIAL STACK WASHER/DRYER

### Built for Reliable Performance

Speed Queen's stack washer/dryer brings an innovative stacked concept that takes up half the floor space that a conventional washer and dryer does when situated side by side. The freestanding softmount design can be installed on all floor types or levels. Both washer and dryer have the same hookups and connections as a standard washer and dryer. No additional plumbing or electrical change is needed. Speed Queen's stack washer/dryer combines heavy-duty construction with reliable operation proven to stand the test of time. They're designed with less moving parts for one reason: so you'll face fewer maintenance problems and less wear and tear down the road. Washer is ADA compliant.

- Graphical display screen with animated and multi-language instructions
- Premium cycle upgrade prompts
- Integrated meter case
- Large capacity meter case standard
- Wash Alert™ capability

#### WASHER (ADA Compliant)

- Rugged suspension system
- Industry leading 1200 RPM spin speed exerts 440 G-force extraction
- Durable stainless steel washtub
- Four-compartment soap dispenser
- Extra-wide 15.5" door opening and 180° door swing

#### DRYER

- Upfront lint filter easy to clean and secured
- Industry's largest door opening 2.06 sq. ft. (1914 cm<sup>2</sup>)
- Quiet, efficient blower system

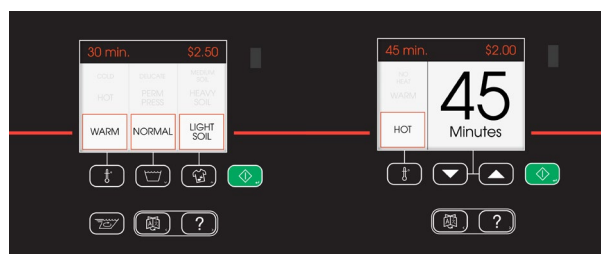

Washer Control





Dryer Control

Quantum® Platinum Controls offer residents unparalleled flexibility. The full-color, multi-language display makes operation intuitive. Your residents have the ability to tailor wash and dry cycles to their specific needs with a special "Speed Cycle" and other premium cycle upgrades. Management is simplified with advanced analytics and on-screen diagnostics to alert your laundry service provider to potential problems, minimizing downtime.

SPECIFICATIONS

# COMMERCIAL STACK WASHER/DRYER

MODEL - see below for all models and activation available		
CONTROL OPTION	Quantum Platinum	
COLOR	White	
CAPACITY - lb (kg)	Washer	21.5 (9.5)
	Dryer	18 (8.2)
OVERALL WIDTH - in (mm)	26.875 (683)	
OVERALL DEPTH - in (mm)	27.73 (704)	
OVERALL HEIGHT - in (mm)	78.17 (1986)	
CYLINDER VOLUME cu. ft. (liters)	Washer	3.42 (96.8)
	Dryer	7.0 (198)
MOTOR SIZE - HP (kW)	0.9 (0.67)	
TYPE OF GAS (GAS MODELS ONLY)	Factory equipped natural	
WATER CONSUMPTION PER CYCLE - g (liter)	13.68 (51.8)	
IWF (WATER FACTOR) - gal/ft <sup>3</sup> (liters/liter/cycle)	4.0 (0.53)	
MEF <sub>2</sub> (Modified Energy Factor) ft <sup>3</sup> /kWh/cycle (Liters/kWh/cycle)	2.20 (62.3)	
AVAILABLE WATER TEMPERATURES	Hot, Warm, Cold	
AVAILABLE CYCLES	Washer	Delicate, Perm Press, Normal, Heavy Soil, Medium Soil, Light Soil, Speed Cycle
	Dryer	High, Medium, Low, Delicate, No Heat
AIR OUTLET DIAMETER - in (mm)	4 (102)	
EXHAUST AIRFLOW - cfm (liters/sec)	220 (105)	
ELECTRICAL REQUIREMENTS	Electric	120/240/60/1-30 amp 120/208/60/1-30 amp
	Gas	120/60/1-15 amp
HEATING ELEMENT	Electric	5350W, 240V 4750W, 208V
	Gas	25,000 Btu
NET WEIGHT - lb (kg)	385 (175)	
SHIPPING WEIGHT - lb (kg)	417 (189)	
SHIPPING DIMENSIONS APPROX. - in (mm)	Width	34 (864)
	Depth	30 (762)
	Height	80 (2032)
AGENCY APPROVALS	Electric	cULus
	Gas	cCSAus

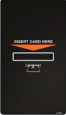
MODELS	VOLTAGE/FREQ/PH	DRAIN	ACTIVATION	
STEDCASP175TW01	120/240/60/1	Electric	Pump	Coin Drop Installed 
STGDCASP115TW01	120/60/1	Gas	Pump	
STEDXASP175TW01	120/240/60/1	Electric	Pump	Prep for Coin 
STEYXASP175TW01*				
STGNXASP115TW01	120/60/1	Gas	Pump	
STGYXASP115TW01*				
STEDYASP175TW01	120/240/60/1	Electric	Pump	Prep for Card 
STGDYASP115TW01	120/60/1	Gas	Pump	

\* Wireless Network Board Factory Installed

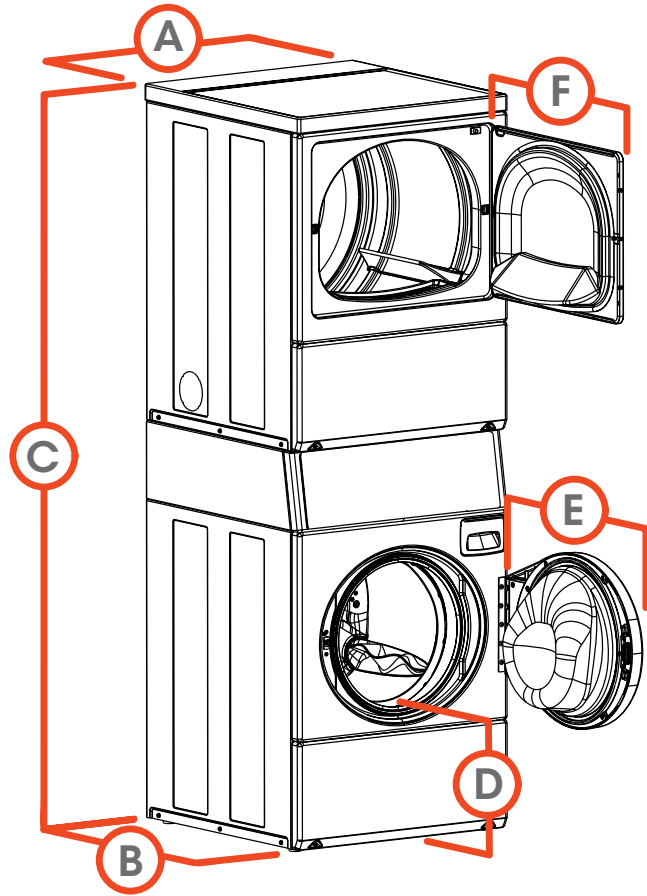

A.	OVERALL WIDTH - in (mm)	26.875 (683)
B.	OVERALL DEPTH - in (mm)	28 (711)
C.	OVERALL HEIGHT - in (mm)	78.17 (1986)
D.	FLOOR TO DOOR OPENING -in (mm)	14.6 (371)*
E.	DOOR SWING - in (mm)	24 (610)

\* For ADA compliance turn legs out from base 0.5 inches

NOTE: Stack washer/dryer requires two power cords. One for washer, one for dryer.

Electric dryers come equipped for 240/60/1 operation. They can be field converted to operate on 208/60/1 with optional 61928 conversion kit. Gas dryers can be field converted for operation on LP gas with optional 458P3 conversion kit.

For the most accurate information, the installation guide should be used for all design and construction purposes. Due to continuous product improvements, design and specifications subject to change without notice. The quality management system of Alliance Laundry Systems' Ripon facility has been registered to ISO 9001:2008.



by Alliance Laundry Systems

[speedqueencommercial.com/multihousing](http://speedqueencommercial.com/multihousing)

AM18-0014 • ©2018 Alliance Laundry Systems LLC