

QUANTUM® PLATINUM COIN DROP INSTALLED, PREP FOR CARD

COMMERCIAL STACK DRYER SOLID DOOR

Built for Reliable Performance

Speed Queen's stack dryer offers the same great features as the single load dryer. Two commercial dryers in the space of one, both operating independently, including independent controls for optimum usage. Defined by its simplicity and its performance, Speed Queen provides everything you need to get the job done - and nothing you don't. Speed Queen's stack dryer combines heavy-duty construction with reliable operation proven to stand the test of time. They're designed with less moving parts for one reason: so you'll face fewer maintenance problems and less wear and tear down the road. Speed Queen's dryers provide the perfect balance of heat, airflow and tumble action for optimal performance and efficiency. Bottom dryer is ADA compliant.

- Graphical display screen with animated and multi-language instructions
- Integrated meter case
- Industry's largest door opening 2.06 sq. ft. (1914 cm²)
- Quiet, efficient blower system
- Door is reversible for installation flexibility
- High efficiency exhaust blower with superior airflow 220 cfm (105 liters/sec)
- 100% serviceable from the front
- Space-saving narrow cabinet 26.875" (683 mm)
- Upfront lint filter easy to clean and secured
- Durable galvanized steel cylinder
- Large capacity meter case standard
- Wash Alert™ capability

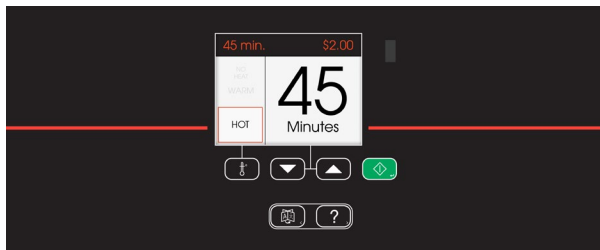

Quantum® Platinum Controls offer residents unparalleled flexibility. The full-color, multi-language display makes operation intuitive, with a special "Anti-Wrinkle" cycle option that gives your residents the ability to tailor cycles to their specific needs. Management is simplified with advanced analytics and on-screen diagnostics to alert your laundry service provider to potential problems, minimizing downtime.

SPECIFICATIONS

COMMERCIAL STACK DRYER

SOLID DOOR

MODEL - see below for all models and activation available	
CONTROL OPTION	Quantum Platinum
COLOR	White
CAPACITY - lb (kg)	18 (8.2)
OVERALL WIDTH - in (mm)	26.875 (683)
OVERALL DEPTH - in (mm)	28 (711)
OVERALL HEIGHT - in (mm)	78.17 (1986)
CYLINDER VOLUME - cu. ft. (liters)	7.0 (198)
MOTOR (THERMAL PROTECTED)	0.33 HP
TYPE OF GAS (GAS MODELS ONLY)	Factory equipped natural
AIR OUTLET DIAMETER - in (mm)	4 (102)
EXHAUST AIRFLOW - cfm (liters/sec)	220 (105)
AVAILABLE CYCLES	High, Medium, Low, Delicate, No Heat
ELECTRICAL REQUIREMENTS ♦	Electric 120/240/60/1-30 amp 120/208/60/1-30 amp
	Gas 120/60/1-15 amp
HEATING ELEMENT	Electric 5350W, 240V 4750W, 208V
	Gas 25,000 Btu
SHIPPING DIMENSIONS APPROX. - in (mm)	Width 33 (838)
	Depth 30 (762)
	Height 80 (2032)
NET WEIGHT - lb (kg)	Electric 270 (122)
	Gas 270 (122)
SHIPPING WEIGHT lb (kg)	Electric 280 (127)
	Gas 280 (127)
AGENCY APPROVALS	Electric cULus
	Gas cCSAus

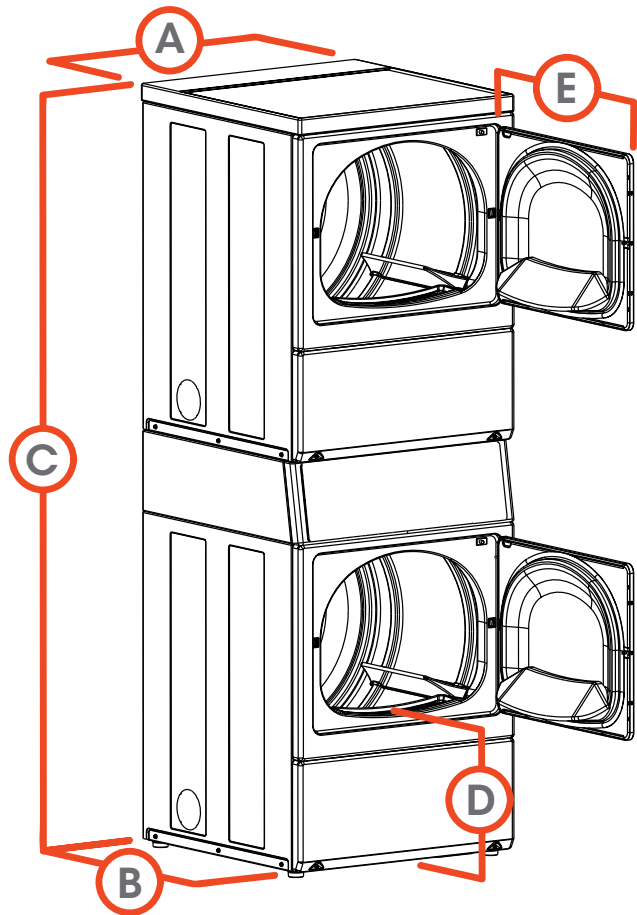

A. OVERALL WIDTH - in (mm)	26.875 (683)
B. OVERALL DEPTH - in (mm)	28 (711)
C. OVERALL HEIGHT - in (mm)	78.17 (1986)
D. FLOOR TO DOOR OPENING -in (mm)	15.44 (392)
E. DOOR SWING - in (mm)	23.5 (597)

MODELS	VOLTAGE/FREQ/PH	ACTIVATION
SSEDCAGS173TW01	120/240/60/1	Electric Coin Drop Installed
SSEDCAGS153TW01	120/208/60/1	
SSGDCAGS113TW01	120/60/1	
SSEYAGS173TW01	120/240/60/1	Prep for Card
SSEYAGS173TW01*	120/240/60/1	
SSEYAGS133TW01	120/208/60/1	
SSGDYAGS113TW01	120/60/1	

* Wireless Network Board Factory Installed

♦ NOTE: Each stack dryer pocket requires its own separate power cord (not supplied).

■ Electric dryers come equipped for 240/60/1 operation. They can be field converted to operate on 208/60/1 with optional 61928 conversion kit. Gas dryers can be field converted for operation on LP gas with optional 458P3 conversion kit.

For the most accurate information, the installation guide should be used for all design and construction purposes. Due to continuous product improvements, design and specifications subject to change without notice. The quality management system of Alliance Laundry Systems' Ripon facility has been registered to ISO 9001:2008.



by Alliance Laundry Systems

speedqueencommercial.com/multihousing

AM18-0119 • ©2018 Alliance Laundry Systems LLC