

# Washer-Extractor

Pocket Hardmount

Variable-Speed

WE-6 Control

Models Starting Serial Code 3120473576

WE-6 Firmware ID Code HRWC18 and greater  
or ARWC01 and greater

— Programming —

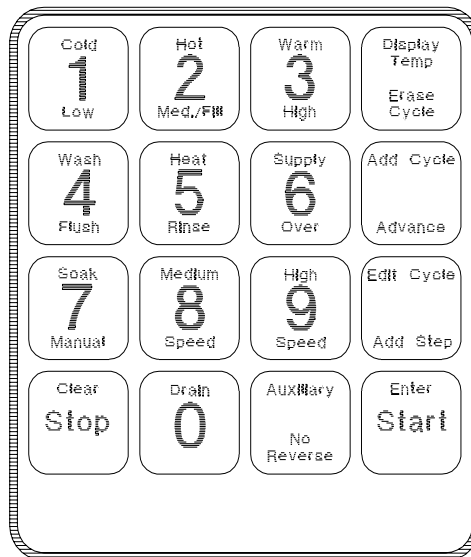

MC010J

**Keep These Instructions for Future Reference.**

(If this machine changes ownership, this manual must accompany machine.)



[www.comlaundry.com](http://www.comlaundry.com)

Part No. F232214R2  
December 2005



# Table of Contents

<b>Safety Information</b> .....	3
Explanation of Safety Messages.....	3
Important Safety Instructions .....	3
<b>Introduction</b> .....	5
Model Identification .....	5
Nameplate Location.....	5
Replacement Parts .....	5
Customer Service.....	5
Introduction.....	7
LED Display .....	7
Simulator.....	7
<b>Programming</b> .....	9
Keypad Identification .....	9
Entering Program Mode .....	9
Setup Mode.....	10
To Enter Setup Mode .....	10
Programming Tutorial .....	14
Programming Hints.....	17
Test Cycle .....	18
Wet Clean Testing.....	18
Manual Mode Control Feature.....	18
Auxiliary Connections .....	19
Balance Timing Sequence for Information on Preprogrammed Cycles .....	19
Cycle Programming.....	20
Displaying a Cycle in Memory .....	20
Editing a Cycle.....	21
Erasing a Cycle in Memory .....	22
Programming a Wet Clean Cycle .....	22
Step Programming .....	22
Programming a Fill without Spray.....	22
Programming a Fill Temperature.....	22
Programming a Supply Step – Models with 8 Supplies .....	24
Programming Heat .....	27
Programming a Wash Step.....	27
Programming a Wash 5 Thermal Cool-Down .....	28
Programming a Wash Drain (Wash 7) Step.....	29
Programming No Reversing .....	29
Programming a Soak Step.....	29
Programming a Drain Step.....	30
Programming a Flush Step.....	30
Programming a Reuse Drain Step with Third Party Water Reuse System.....	30
Programming a Fill through Auxiliary Fill Valve with Third Party Water Reuse System .....	31
Programming a Spin Step .....	31
Spins.....	32
Stop Routine.....	32

© Copyright 2005, Alliance Laundry Systems LLC

All rights reserved. No part of the contents of this book may be reproduced or transmitted in any form or by any means without the expressed written consent of the publisher.

Programming a Spray Rinse Step .....	32
Auxiliary .....	33
Balance Detection .....	34
Balance Switch Detection .....	35
Simulator Operation and Program Transfer .....	35
Simulator Operation .....	35
Transferring All Cycles from Computer to Simulator .....	37
Transferring One Cycle from Computer to Simulator .....	37
Transferring All Cycles from Simulator to Computer .....	37
Transferring One Cycle from Simulator to Computer .....	38
Preprogrammed Cycles .....	38
Cycle Categories .....	39
Standard Supply Legend .....	39
Standard Cycle Charts .....	40

# Safety Information

## Explanation of Safety Messages

Precautionary statements (“DANGER,” “WARNING,” and “CAUTION”), followed by specific instructions, are found in this manual and on machine decals. These precautions are intended for the personal safety of the operator, user, servicer, and those maintaining the machine.

	<b>DANGER</b>
<b>DANGER indicates the presence of a hazard that will cause severe personal injury, death, or substantial property damage if the danger is ignored.</b>	

	<b>WARNING</b>
<b>WARNING indicates the presence of a hazard that can cause severe personal injury, death, or substantial property damage if the warning is ignored.</b>	

	<b>CAUTION</b>
<b>CAUTION indicates the presence of a hazard that will or can cause minor personal injury or property damage if the caution is ignored.</b>	

Additional precautionary statements (“IMPORTANT” and “NOTE”) are followed by specific instructions.

**IMPORTANT:** The word “IMPORTANT” is used to inform the reader of specific procedures where minor machine damage will occur if the procedure is not followed.

**NOTE:** The word “NOTE” is used to communicate installation, operation, maintenance or servicing information that is important but not hazard related.

## Important Safety Instructions

	<b>WARNING</b>
<b>To reduce the risk of fire, electric shock, serious injury or death to persons when using your washer, follow these basic precautions:</b>	
W023	

1. Read all instructions before using the washer.
2. Refer to the **GROUNDING INSTRUCTIONS** in the **INSTALLATION** manual for the proper grounding of the washer.
3. Do not wash textiles that have been previously cleaned in, washed in, soaked in, or spotted with gasoline, kerosene, waxes, cooling oils, dry-cleaning solvents, or other flammable or explosive substances as they give off vapors that could ignite or explode.
4. Do not add gasoline, dry-cleaning solvents, or other flammable or explosive substances to the wash water. These substances give off vapors that could ignite or explode.
5. Under certain conditions, hydrogen gas may be produced in a hot water system that has not been used for two weeks or more. **HYDROGEN GAS IS EXPLOSIVE.** If the hot water system has not been used for such a period, before using a washing machine or combination washer-dryer, turn on all hot water faucets and let the water flow from each for several minutes. This will release any accumulated hydrogen gas. The gas is flammable, do not smoke or use an open flame during this time.
6. Do not allow children to play on or in the washer. Close supervision of children is necessary when the washer is used near children. This is a safety rule for all appliances.
7. Before the washer is removed from service or discarded, remove the door to the washing compartment.
8. Do not reach into the washer if the wash drum is moving.

## Safety Information

9. Do not install or store the washer where it will be exposed to water and/or weather.
10. Do not tamper with the controls.
11. Do not repair or replace any part of the washer, or attempt any servicing unless specifically recommended in the user-maintenance instructions or in published user-repair instructions that the user understands and has the skills to carry out.
12. To reduce the risk of an electric shock or fire, DO NOT use an extension cord or an adapter to connect the washer to the electrical power source.
13. Use washer only for its intended purpose, washing textiles.
14. Never wash machine parts or automotive parts in the machine. This could result in serious damage to the basket.
15. ALWAYS disconnect the washer from electrical supply before attempting any service. Disconnect the power cord by grasping the plug, not the cord.
16. Install the washer according to the INSTALLATION INSTRUCTIONS. All connections for water, drain, electrical power and grounding must comply with local codes and be made by licensed personnel when required.
17. To reduce the risk of fire, textiles which have traces of any flammable substances such as vegetable oil, cooking oil, machine oil, flammable chemicals, thinner, etc., or anything containing wax or chemicals such as in mops and cleaning cloths, must not be put into the washer. These flammable substances may cause the fabric to catch on fire by itself.
18. Do not use fabric softeners or products to eliminate static unless recommended by the manufacturer of the fabric softener or product.
19. Keep washer in good condition. Bumping or dropping the washer can damage safety features. If this occurs, have washer checked by a qualified service person.
20. Replace worn power cords and/or loose plugs.
21. Be sure water connections have a shut-off valve and that fill hose connections are tight. CLOSE the shut-off valves at the end of each wash day.
22. Loading door MUST BE CLOSED any time the washer is to fill, tumble or spin. DO NOT bypass the loading door switch by permitting the washer to operate with the loading door open.
23. Always read and follow manufacturer's instructions on packages of laundry and cleaning aids. Heed all warnings or precautions. To reduce the risk of poisoning or chemical burns, keep them out of the reach of children at all times (preferably in a locked cabinet).
24. Always follow the fabric care instructions supplied by the textile manufacturer.
25. Never operate the washer with any guards and/or panels removed.
26. DO NOT operate the washer with missing or broken parts.
27. DO NOT bypass any safety devices.
28. Failure to install, maintain, and/or operate this washer according to the manufacturer's instructions may result in conditions which can produce bodily injury and/or property damage.

**NOTE: The WARNINGS and IMPORTANT SAFETY INSTRUCTIONS appearing in this manual are not meant to cover all possible conditions and situations that may occur. Common sense, caution and care must be exercised when installing, maintaining, or operating the washer.**

Any problems or conditions not understood should be reported to the dealer, distributor, service agent or the manufacturer.

# Introduction

## Model Identification

Information in this manual is applicable to these models:

UW35PV	UW100PV
UW60PV	UW125PV
UW80PV	UW150PV

## Nameplate Location

The nameplate is located on cagewrap, on side of AC Inverter Drive Compartment and on Electric Heat Contractor Box (if equipped). Always provide the machine's serial number and model number when ordering parts or when seeking technical assistance. Refer to *Figure 1*.

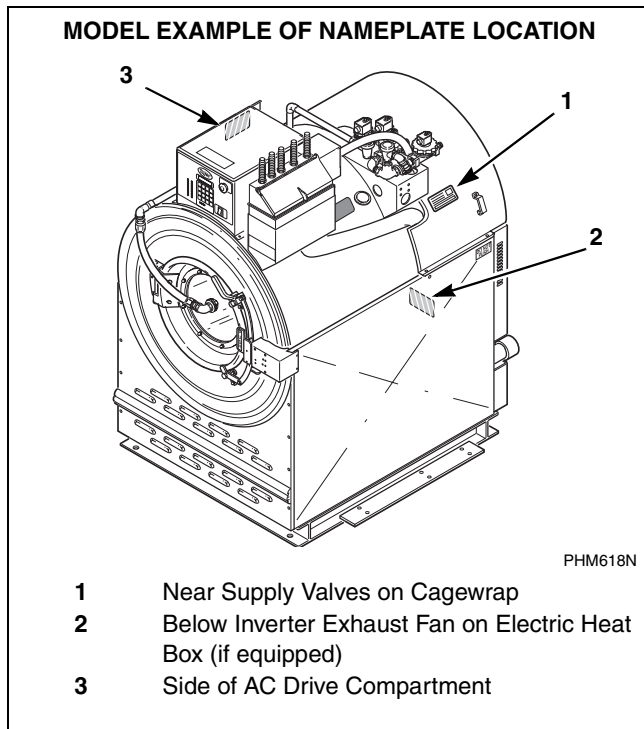

Figure 1

## Replacement Parts

If literature or replacement parts are required, contact the source from which the washer-extractor was purchased or contact Alliance Laundry Systems LLC at (920) 748-3950 for the name of the nearest authorized parts distributor. A parts manual may be ordered by returning the reply card provided with each washer-extractor.

## Customer Service

For technical assistance, contact your local distributor or call:

(920) 748-3121  
Ripon, Wisconsin

A record of each washer-extractor is on file with the manufacturer. Always provide the machine's serial number and model number when ordering parts or when seeking technical assistance. Refer to *Figure 2*.

**Introduction**

<b>Model Number Familiarization Guide</b>		
Sample Model Number: <b>UW60PVXU80001</b>		
<b>UW</b>	Model Number Prefix	
<b>60</b>	Washer-Extractor Capacity (pounds dry weight of laundry)	
<b>P</b>	Type of Electrical Control	P = WE-6 Control
<b>V</b>	Washer-Extractor Speed Capabilities	V = 7 Speeds
<b>X</b>	Electrical Characteristics	
<b>U8</b>	Design Series	J = Jog Feature (UW150 Models Only)
<b>0001</b>	Option Identification (varies from machine to machine)	

Model No.	UW60PVXU80001			
Serial No.	000000000000			
Voltage	200 – 240	Amps	14	
Circuit Breaker	20 Amps			
Hz	50 – 60	Wire	2/3	Phase 1/3
Max. Load	60 LB	27 KG	Max. Speed	813 RPM
Elec. Heating	N/A		Steam Press.	N/A PSI
				0.0 BAR
<b>Drawings:</b>				
ETL Listed Conforms To ANSI/UL Std. 1206, 3rd Ed Certified To CAN/CSA Std. C22.2 No.53-1968				

EXAMPLE OF NAMEPLATE

PHM533R

Figure 2



## Introduction

The WE-6 control is a field-programmable solid-state control capable of storing and running up to 39 preprogrammed ready-to-use cycles. A detailed description of these cycles can be found in the *Standard Cycle Charts* section.

Never turn the power off while the control mode switch is in the PROGRAM position. Programmed data and cycle information will be lost and need reprogramming. Always return the mode switch to RUN position before turning the power off.

Never leave the mode switch key inserted in the switch lock where it may be accessible to unauthorized personnel not familiar with programming procedures.

The control in this washer-extractor is continuously on the alert for problems within the machine. When the control detects a problem, it immediately flashes a letter or number or both on the display. It may activate the signal buzzer as well.

## LED Display

The WE-6 control has a six-digit LED display. References to display indications pertain to the first four digits of the display reading left to right. The last two digits on the right side of the display will indicate either the last cycle used or the current cycle in progress. Refer to *Figure 3*.

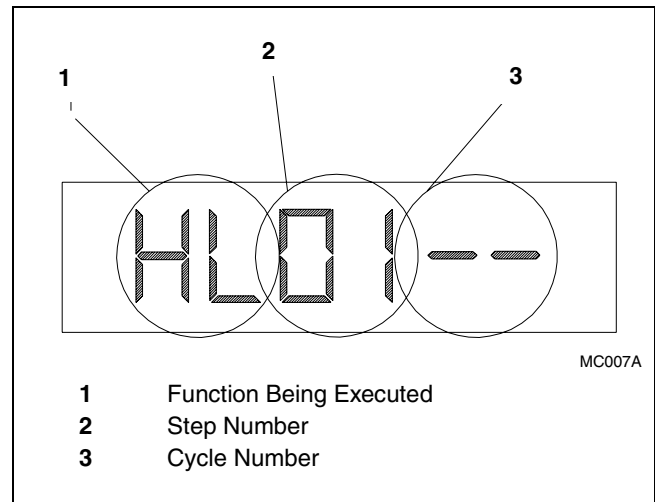

Figure 3

*Table 2* lists the various displays and what they mean.

## Simulator

A simulator, available at extra cost, is an optional accessory that allows the user to preprogram cycles for all WE-6 control washer-extractors in a facility. The information is preprogrammed into the simulator, the simulator is connected to the washer-extractor needing updates and the preprogrammed information is downloaded into the WE-6 control on the washer-extractor.



# Programming

## Keypad Identification

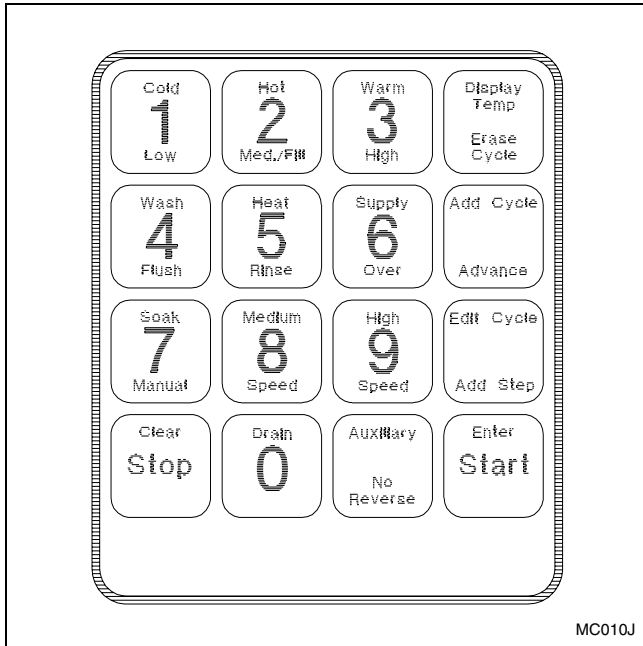

Figure 4

All sixteen keypads are used in Program Mode. Specific functions are printed in *red* on keypads. Keypad 1–6 and Auxiliary/No Reverse keypad are dual function keypads in Program Mode. In each instance (with exception of Warm/High keypad), when a keypad is first pressed in a programming step, the word printed at top of keypad applies. In most instances, the next time same keypad is pressed or if another keypad has already been pressed in programming a step, the word printed on bottom of keypad applies.

## Entering Program Mode

**NOTE: Machines are factory programmed with basic cycles to make the units operational without programming at installation.**

1. Locate key-operated programming switch on left side of control module, viewed from front.
2. Insert key and turn switch to PROGRAM position.
3. Display will read “CY00.”

## Programming

### Setup Mode

**NOTE: Enter Setup Mode while in Program Mode. Refer to *Entering Program Mode* section.**

In Setup Mode, prompting the WE-6 allows the following options:

- Displaying sump temperature in Centigrade or Fahrenheit (FAR or CEN).
- Recognizing and controlling one or two independent drains. (Two independent drains will apply only for special applications.)
- Enabling or disabling Advance keypad in Run Mode.
- Enabling or disabling Manual Mode.
- Enabling or disabling wet clean functions (affects Auxiliary 1 and 2 outputs).
- Selecting balancing routine (active if inverter balance detection is utilized). Long balance (L BAL) or short balance (S BAL) routine timing.
- Selecting machine model.
- Reading or resetting cycle count.

**NOTE: Machine comes from manufacturer with WE-6 control set up for use with machine in which it is installed. If control needs to be reset, refer to *To Enter Setup Mode*.**

**IMPORTANT: WE-6 control must be configured for washer-extractor in which it is installed. Failure to set up control for proper machine may cause control to malfunction and void warranty.**

**IMPORTANT: Once WE-6 control has been through model Setup Mode one time, it will store machine model configuration information in control memory and never display “SETUP” again. It is very important that WE-6 control PC board, or the socketed chips in this PC board are NEVER removed from one washer and installed in another washer without first updating and verifying model configuration as described in instruction. Warranty will be void if not set up properly.**

**IMPORTANT: DO NOT install an earlier version WE-6 control board. THIS WILL CREATE HAZARDOUS CONDITIONS FOR OPERATOR AND VOID WARRANTY. Contact Alliance Laundry Systems for additional details and information regarding free replacement of old control boards.**

**IMPORTANT: WE-6 door lock circuit MUST NOT allow entry into door until basket has come to a complete stop.**

### To Enter Setup Mode

1. Enter Program Mode. Refer to *Entering Program Mode* section.
2. Press Auxiliary keypad, 2 keypad, and 9 keypad *in that order*. Display shows either “CEN” (for degrees shown in Centigrade) or “FAR” (for degrees shown in Fahrenheit). Press 0 keypad to change selection.
3. Press Enter keypad.
4. Display shows either “1DRAIN” or “2DRAIN.” The normal prompt for most applications is “1DRAIN.” “2DRAIN” is used only for special applications. Consult manufacturer for full details. To choose alternate feature, press 0 keypad.

**NOTE: Enabling second drain via Auxiliary 2 output precludes control of recirculation pump and is not necessary for Premium Wet Clean Module.**

5. Press Enter keypad.
6. Display shows “ADV” or “NO ADV.” The prompt “NO ADV” will disable Advance keypad in Run Mode, thereby preventing operator from advancing control through steps of cycle before completion. In addition, it will not be possible to advance to any step before starting a cycle if “NO ADV” is selected. Press 0 keypad to select enable or disabling the Advance feature.
7. Press Enter keypad
8. Display will read either “MANUAL” or “NO MAN.” If “MANUAL” is displayed, Manual Mode will be *enabled* during normal operation. If “NO MAN” is displayed, Manual Mode will be *disabled* when a cycle is run, even if Manual operation keypad sequence is entered. To select enabling or disabling the manual mode feature, press 0 keypad.
9. Press Enter keypad. When desired Manual Mode option is displayed, display will read “WET CL” or “NO WCL.” If “WET CL” is displayed, wet clean functions are enabled. If “NO WCL” is displayed, press 0 keypad to enable or disable Wet Clean feature.

10. Press Enter keypad. When desired Wet Clean option is displayed, display will read “S BAL” (short balance timing sequence) or “L BAL” (long balance timing sequence). Refer to *Table 1* for appropriate sequence. Press 0 keypad to change selection.

11. Press Enter keypad.

Model	Display
UW60PVT	L BAL
Design 5 models greater than 60 lbs.	L BAL
Design 6 models and greater, 60 lbs. and less	S BAL
Design 6 models and greater 60 lbs. and over	L BAL

Table 1

12. Press Enter keypad. Display will read “UW35,” “UW60,” “UW80,” “UW100,” “UW125” or “UW150.” Press 0 keypad until display reads correct model. Model selection must be correct to ensure proper machine function.

13. Press Enter keypad when desired balance times sequence is displayed. Display will read “USEDxx.” (The “xx” means number of cycles run.)

The count can be left as it reads on display, or it can be reset to “00.”

- To leave count unaltered, press Enter keypad to return to normal programming mode.
- To reset count, press 0 keypad. Display will read “USED00.”

Press Enter keypad to return to normal programming mode.

Control stores cycle count in its memory. If power to control is interrupted, count will automatically be set at “00.”

If a daily count is desired, display should be read at end of day and then reset prior to running next day’s first cycle. (Display resets automatically after cycle count reaches 99.)

14. Return Program Mode switch to RUN position and remove key. Prompting is complete.

**NOTE: Prompting will change parameters in all cycles programmed.**

## Programming

Programming Keypad		
Keypad	Red Keypads	Description
1	Cold Low	<b>Cold</b> is pressed when step requires cold water. <b>Low</b> is pressed for low-level fill.
2	Hot Med./Fill	<b>Hot</b> is pressed when step requires hot water. <b>Med./Fill</b> is pressed to select medium water level. <b>Fill</b> is pressed in Manual Mode to operate fill valves.
3	Warm High	<b>Warm</b> is pressed when step requires warm water. <b>High</b> is pressed for high-level fill.
Erase Cycle	Erase Cycle	<b>Erase Cycle</b> and a two-digit cycle code number are pressed to erase a cycle from memory.
4	Wash Flush	<b>Wash</b> is pressed when step is a wash or dilution rinse. Then keypad <b>1, 2, 3, 4, 5,</b> or <b>6</b> is pressed to choose type of agitation. Press keypad 7 after Wash keypad (in Program Mode when creating a new step) to create a Wash Drain Step. Refer to <i>Programming a Wash Step</i> and <i>Programming a Drain Step</i> sections for additional details. <b>Flush</b> is pressed to keep drain open when water is added to machine. A temperature selection keypad ( <b>Hot, Cold, Warm</b> ) must be pressed before <b>Flush</b> keypad. When <b>Flush</b> is programmed, water is added through door spray nozzle only; basket rotates in low speed forward only.
5	Heat Rinse	<b>Heat</b> is pressed when auxiliary heat is needed. This must be followed by a specific temperature selection, such as 165°F. Temperature must be entered; then a time assigned to reach that temperature must be entered. <b>Rinse</b> is pressed when a spin-spray rinse (not available on UW125 models) is desired. Before <b>Rinse</b> keypad is pressed, a temperature keypad must be pressed: <b>Hot, Cold,</b> or <b>Warm</b> . Drain will remain open, and basket will rotate at medium-spin speed (high speed on two-speed only machines). Water is added through door spray nozzle only.
6	Supply Over	<b>Supply</b> is pressed when soap, bleach, or other chemicals are desired. Keypad <b>1, 2, 3, 4,</b> or <b>5</b> must be pressed to indicate specific supply dispenser being used. Combinations of these supplies can be programmed. Refer to <i>Programming a Supply Step</i> . <b>Over</b> is pressed when an overflow of water is desired. Drain is closed and water is added, using fill valves only, without regard to level. Water flows out overflow connection for time assigned to step.
Add Cycle	Add Cycle	<b>Add Cycle</b> is pressed to begin process of programming a new cycle into memory.

Table 2

Table 2 (Continued)

Programming Keypad (Continued)		
Keypad	Red Keypads	Description
7	Soak	<b>Soak</b> is used when no agitation is desired. This follows a fill and/or supply step. Time must be assigned in hours and minutes. (Wash 3 also provides no agitation.)
8	Medium Speed	<b>Medium Speed</b> is pressed when a medium spin <i>only</i> is desired for washing delicate items not suited for high speed spin or when an intermediate spin is desired.
9	High Speed	<b>High Speed</b> is pressed when a fast spin is desired. Pressing <b>High Speed</b> keypad once will activate the H1 spin; twice, the H2 spin; and three times, H3 spin.
Edit Cycle	Edit Cycle	<b>Edit Cycle</b> is pressed followed by a two-digit cycle code number to display steps of a preprogrammed cycle. Cycle may be altered during edit cycle procedure by deleting, changing, or adding steps.
Add Step	Add Step	<b>Add Step</b> is pressed to add a step to an existing cycle during edit cycle procedure.
Clear (black on red background)	Clear (black on red background)	<b>Clear</b> is pressed when an error has been made in programming a step. Instead of pressing <b>Enter</b> as step is completed, press <b>Clear</b> to eliminate incorrect information. ( <b>Clear</b> should never be pressed when displaying a cycle unless a particular step is to be eliminated or changed. Refer to <i>Displaying a Cycle in Memory</i> .)
0	Drain	<b>Drain</b> is pressed after a wash, dilution rinse, or soak step is programmed in order to remove water from machine. A time must be assigned that will allow machine to reach empty. If control has been prompted for two independent drains, press <b>1</b> keypad or <b>2</b> keypad for desired drain valve. Refer to <i>Set Up Mode</i> section in <i>Operation Manual</i> . There are always four possible selections for drain step. For special applications utilizing "2DRAIN," contact manufacturer. These are selected after Drain keypad is pressed. Press <b>1</b> keypad for drain 1 (main drain), <b>2</b> keypad for a drain to reuse tank A, and <b>3</b> keypad for a drain to reuse tank B or <b>5</b> keypad for a drain to sewer. Drain 5 is identical to drain 1 step, without load rebalancing during drain step (this minimizes drain time). The option for reducing drain time is only available for Drain 5. All other drains require the full amount of time. Programming a medium spin speed, or spray rinse after a Drain 5 Step is recommended. If Drain 5 is programmed before an H3 spin, control will default to speed below maximum spin speed. Program a Wash 7 step for potentially the shortest drain step. Refer to <i>Programming a Wash Step</i> .
Auxiliary No Reverse	Auxiliary No Reverse	<b>Auxiliary</b> is pressed to activate buzzer or other auxiliary output. NOTE: Auxiliary 4 is used to activate recovery fill valve for machines equipped with water reuse system. <b>No Reverse</b> is used to rotate basket in one direction only during a wash step and should be pressed just before pressing <b>Enter</b> keypad.
Enter	Enter	<b>Enter</b> is pressed to enter programming information into control's memory.

## Programming

### Programming Tutorial

The following procedure guides the programmer through a complete cycle and allows hands-on experience for programming cycles. The complete cycle is listed at the end of this section.

1. Enter Program Mode. Refer to *Entering Program Mode* section.
2. Press Add Cycle keypad. Display will read "ACYC00."
3. A two-digit number from 01 to 39 must be entered. Refer to *Standard Cycle Charts* section.

**NOTE: Cycle number 01 is recommended because standard program versions use this short cycle for performing a chemical supply setup.**

4. If using cycle number 01, press 0 keypad, then 1 keypad, then Enter keypad. Display will read "CYC01."
  - a. If display alternately flashes "EXISTS" and "EDIT?," press Clear/Stop keypad. Display will read "CYC01."
  - b. Erase existing cycle by pressing Erase Cycle keypad. Display will read "ECYC01." Press 0 keypad, then 1 keypad, then Enter keypad. Display will read "WAIT" briefly and then "CYC01."
  - c. Press Add Cycle keypad. Display will read "ACYC01." Press 0 keypad, then 1 keypad, then Enter keypad. Display will show "0101." ("01" means step 1 and "01" means cycle number.)
5. Enter desired water temperature and fill level. For this tutorial, step 1 will be Hot Fill and Low Level.
  - a. Press Hot keypad (2) and then Low keypad (1). Display will read "HL0101."
  - b. Press Enter keypad. Display will read "M---S."
  - c. Enter desired fill time. (4 minutes is recommended.) Press 4 keypad. Display will read "4M-00S." ("4M" means 4 minutes and "00S" means 0 seconds.)
6. Press Enter keypad. Display will read "0201," indicating that control is ready for step 2 of cycle 01.
7. For this tutorial, step 2 in cycle will be an addition of a supply step.
  - a. To add supply No. 1, press Supply keypad (6) and then 1 keypad. Display will read "S10201."
  - b. Press Enter keypad and display will read "M---S."
  - c. Enter desired time in minutes and seconds for supply valve to be turned on (thirty seconds is the recommended time).  
Press 0 keypad for minutes, and display will read "0M-00S."  
Press 3 keypad and then 0 keypad. Display will read "0M-30S," indicating a supply time of thirty seconds.
8. Press Enter keypad. Display will change to read "0301," indicating control is ready for step 3 of cycle 01.
9. If no other supply is required, the next step is to choose type of wash desired and assign it a time. Refer to *Programming a Wash Step* section for available wash types. For this tutorial choose a wash with standard reversing action (Wash 1) and a time of six minutes.
  - a. Press Wash keypad (4) and then 1 keypad. Display will read "W10301."
  - b. Press Enter keypad. Display will read "M---S."
  - c. Enter desired wash time (6 minutes is recommended). Press 6 keypad. Display will read "6M-00S," indicating a wash step of six minutes.
10. Press Enter keypad. Display will read "0401," indicating that control is ready for step 4 of cycle 01.



11. For this tutorial, step 4 will be a drain step.
  - a. Press Drain keypad (0). (A drain step usually follows a wash step). Display will read "D-0401."

This program allows a choice among drains 1, a, b or 5 ("5" uses sewer drain). (NOTE: 1 is sewer, "a" is Tank a and "b" is Tank b.) For this application, press 5 keypad. Display will read "D50401."

**NOTE: Drain 5 is identical to Drain 1 without the rebalancing attempts. Program Drain 5 to shorten cycle time. Programming a medium spin speed or a spray rinse step after a Drain 5 step is recommended. Do NOT program a Drain 5 step if an H1 spin step or higher is the next step.**

- b. Press Enter keypad. Display will read "M---S."
- c. Enter *maximum* time desired for control to allow machine to drain to empty. (One minute is recommended.) Press 1 keypad. Display will change to "1M-00S," indicating a drain step of one minute.

**NOTE: The manufacturer does not recommend more than one minute for a drain step. If machine does not drain in amount of time programmed, "EMPTY" alarm will be displayed. Refer to *Error Recovery Routine in Operation Manual*.**

12. Press Enter keypad. Display will now read "0501," indicating that control is ready for step 5 of cycle 01.
13. For this tutorial, step 5 in cycles will be a warm rinse.
  - a. Press Warm keypad (3) and then Rinse keypad (5). Display will read "WR0501."
  - b. Press Enter keypad. Display will read "M---S."
  - c. Enter rinse time in minutes and seconds. A spray rinse lasting 2-1/2 minutes is recommended.  
  
Press 2 keypad. Display will read "2M-00S."  
  
Press 3 keypad and 0 keypad. Display will read "2M-30S," indicating a spray rinse of 2 minutes and 30 seconds.
14. Press Enter keypad. Display will read "0601," indicating that control is ready for step 6 of cycle 01.

15. For this tutorial, step 6 in cycle will be a warm fill and high level for a dilution rinse.

**NOTE: Rinse key controls a *spin-spray* rinse. A *dilution* rinse is the same as a wash step without the addition of detergents. Refer to *Programming a Wash Step* section.**

- a. Press Warm keypad (3) *twice* to turn on two hot and two cold water valves to reduce fill time. Display will read "W-0601." Press High keypad (3 keypad). Display will read "WH0601."
- b. Press Enter keypad. Display will read "M---S."
- c. Enter desired time for control to allow machine to fill to high level (five minutes is recommended). Press 5 keypad. Display will read "5M-00S" indicating a dilution rinse of 5 minutes.

**NOTE: If machine does not fill high level in amount of time programmed, "FILL" alarm will be displayed. Refer to *Error Recovery Routine in Operation Manual*.**

16. Press Enter keypad. Display will read "0701."
17. For this tutorial, step 7 in cycle will be an add sour.
  - a. Press Supply keypad (6) and 3 keypad (3 is for supply 3 location). Display will read "S30701."
  - b. Press Enter keypad. Display will read "M---S."
  - c. Enter length of time for supply to be activated (thirty seconds is recommended).  
  
Press 0 keypad for minutes; press 3 keypad and then 0 keypad for seconds. Display will read "0M-30S" indicating an add sour step of 0 minutes and 30 seconds.
18. Press Enter keypad. Display will read "0801," indicating that control is ready for step 8.

## Programming

19. For this tutorial, step 8 will be an agitation action for dilution rinse.

a. Press Wash keypad (4) and 1 keypad to program an action with normal reversing. Refer to **Programming a Wash Step** section. Display will read “W10801.”

b. Press Enter keypad. Display will read “M---S.”

c. Enter time for dilution rinse (three minutes is recommended).

Press 3 keypad. Display will read “3M-00S,” indicating an agitation action dilution rinse of 3 minutes.

20. Press Enter keypad. Display will read “0901,” indicating that control is ready for step 9.

21. For this tutorial, step 9 in cycle 9 will be a dilution rinse water drain.

a. Press Drain keypad. Display will read “D-0901.” Press 1 keypad for draining to sewer. Display will read “D10901.”

b. Press Enter keypad. Display will read “M---S.”

c. Enter length of time control will allow machine to drain (one minute is recommended).

Press 1 keypad. Display reads “1M-00S,” indicating a drain step of one minute.

**NOTE: Programming a Drain 5 step is identical to Drain 1, but with a reduced time because there are no rebalancing attempts. To program Drain 5, press 5 keypad after Drain keypad. “D50901” will display. Do not program an H3 spin after Drain 5. Control will default to a less than maximum spin speed during H3 (Drain 5 does not attempt to rebalance the load). It is recommended to program a medium speed spin or spray rinses after Drain 5.**

22. Press Enter keypad. Display will read “1001,” indicating that control is ready for step 10 of cycle 01.

23. For this tutorial, step 10 in cycle will be an extract step.

a. Press Medium Speed keypad (8). Display will read “MS1001,” indicating a medium-speed spin.

b. Press Enter keypad. Display will read “M---S.”

c. Enter length of time for medium-speed spin (one minute is recommended).

Press 1 keypad. Display will read “1M-00S,” indicating 1 minute and 0 seconds.

24. Press Enter keypad. Display flashes “SDLY” (slow-down delay) for one second.

Display will read “0M-00S,” allowing programmer to enter time for a slow-down delay.

**NOTE: Do not program a slow-down delay time if the slow-down delay is followed by a spin (all consecutive spins are skipped when a slow-down delay is programmed).**

For no slow-down delay, press Enter keypad.

25. For this tutorial, step 11 in cycle will be a spin step.

a. Press High Speed keypad (9) once. Display will read “H11101.”

**NOTE: Pressing High Speed keypad repeatedly when programming a high speed step will cause control display to proceed from “H1” to “H2,” and then to “H3,” maximum-speed spin. After “H3” appears and High Speed keypad is pressed again, “H1” will reappear.**

b. Press Enter keypad. Display will read “M---S.”

c. Enter a length of time for high speed spin (six minutes is recommended). Press 6 keypad. Display will read “6M-00S.”

**NOTE: High Speed spin is not preceded automatically by medium-speed spin as with nonvariable-speed UW rigid-mount models. Medium-speed spin *only* or high speed spin 1, 2, or 3 may be programmed.**

26. Press Enter keypad. Display will flash “SDLY” (slow-down delay) for one second. (“SDLY” also displays during the entire actual delay time.) Display will read “0M-00S,” prompting programmer to enter a time for slow-down delay. Display will read “1201.”

**NOTE:** For machines with a WE-6 Firmware ID Code of HRWC10 or earlier, a slow-down delay of 60 seconds minimum *must* be programmed after each medium-speed, spray-rinse or high speed 1 or a delay of 99 seconds must be programmed after each high speed spin 2 or high speed 3. For machines with software code HRWC18 or later, no slow-down is required.

**NOTE:** For machines with a WE-6 Firmware ID Code of HRWC12 or later, if application requires that water fill valves remain off while basket is coasting to a stop, enter desired delay time (Example: 60 seconds). Press Enter keypad. The last spin should have no spin delay (“0M-00S”).

27. The previous step ends tutorial. Cycle 01, consisting of 11 steps, has been programmed.

To end cycle, turn Program Mode switch located on left side of control module to RUN position and remove key. Display will read “NEXT.”

Programmer can select Cycle 01 and press Enter keypad to run cycle as it is set up; or a cycle of the programmer’s own design can be programmed.

**NOTE:** Cycle 01 can be reprogrammed as machine came from factory. Refer to *Standard Cycle Charts* section or it can remain as set up in tutorial.

Tutorial Cycle		
Step	Description	Min:sec
1	Hot Fill to Low Level	4:00
2	Supply 1	0:30
3	Wash 1	6:00
4	Drain 5	1:00
5	Warm Spray Rinse	2:30
6	Warm/Warm Fill to High Level	5:00
7	Supply 3	0:30
8	Wash 1	3:00
9	Drain 1	1:00
10	Medium Speed Spin	1:00
11	High Speed Spin No. 1 SDLY Stop Routine	6:00 0:00

Table 3

## Programming Hints

Refer to *Standard Cycle Charts* section.

**NOTE:** The control can only be programmed step by step.

When entering timed portion of a step (such as a fill), use a time that is reasonable for local installation. If water pressure is low or if water lines are small, increase time allowed. Drain lines must be sized correctly to empty the machine in less than one minute.

**NOTE:** Drain times of more than one minute are not recommended.

Except for soak, heat, and cool-down (Wash 5) steps, which are timed in hours and minutes, the maximum time per step is 9 minutes and 99 seconds. If more time is needed, add more steps to total complete time desired. For example, if a 15-minute wash is desired, program a wash step for 9 minutes and 00 seconds, immediately followed by another wash step for 6 minutes and 00 seconds.

When a fill or addition of supplies without agitation is desired, first program a Wash 3 step for 0 minutes and 01 seconds. Program fill or supply step as desired. When control advances to next step, it will *remain* in Wash Mode as programmed in previous step unless instructed to do otherwise.

Program a wash drain before a fill step. A wash drain has no rotation, has the sewer (main) drain open and does not attempt to rebalance the load, if followed by a fill. Refer to *Programming a Wash Step* section and *Programming a Drain Step* section for additional details.

## Programming

### Test Cycle

Cycle number 39 is a test cycle used to analyze washer-extractor functions.

Step 01 in cycle number 39 is a cold fill to low level. This step is designed to give not quite enough time to complete a fill, causing the display to read "FILL." Press the Start keypad to continue the fill, and the test cycle will proceed.

Step 02 in the test cycle is a drain step. Again, the time allotted is shorter than it would be in a normal cycle. The display will read "EMPTY." To proceed, press the Start keypad.

The steps in the test cycle are relatively short with the exception of steps 3, 21, 25, 27, 28, and 29. These can be shortened by pressing the Advance keypad to go on to the next step.

The operator may skip to any next step in the cycle with the exception of a drain step: Drain steps must be allowed to complete. To skip forward in the test cycle, press the Advance keypad.

**NOTE: The Advance feature may be disabled.**

### Wet Clean Testing

Wet clean processing outputs are tested through the energizing of the Auxiliary 1 output in step 18 and Auxiliary 2 output in step 19. Steps 30 through 41 are designed to test water reuse processing, if this option is installed. If it is not, the outputs associated with each step will be energized, and the cycle will conclude normally.

**NOTE: Prompts for "1DRAIN" and "WET CL" must be selected when prompting the WE-6 microcomputer in order for steps 18 and 19 to work properly for wet clean processing.**

### Manual Mode Control Feature

Manual control is available only while a preprogrammed cycle is in progress, and if Manual Mode is prompted in the WE-6 programming. With the exception of motor speeds, the reuse tank B drain and tank A and B fill valves, and the door unlock output, the WE-6 computer outputs can be operated manually from the keypad. (In order to ensure proper sequencing, all motor speeds are always controlled by the computer.)

**NOTE: When the Manual Mode control feature is activated, the operator must supply on/off commands for the controllable outputs. If an output is on, it will remain on until turned off by the operator or until the assigned time for the Manual Mode expires. This can be as long as 9 minutes and 99 seconds.**

In normal operation, when the Program Mode switch is in the RUN position, only the operations printed in *black* on the keys are accessible to the operator.

During the Manual Mode, normal cycle timing is suspended. When the Manual Mode is entered, the operations printed in *red* on the keys and mentioned in the following discussion are activated.

Entering the Manual Mode during a fill operation is not recommended. This bypasses the water-level switch inputs, and the water *must* be turned off manually by the operator.

The following procedure must be accomplished within three seconds in order to enter the Manual Mode:

1. Press the Manual key.
2. Then press three number keys to assign a time in minutes and seconds to the Manual Mode. For example, press key 2, key 3, and key 0 to enter the Manual Mode for 2 minutes and 30 seconds.
3. Then press the Add Step key.

When the computer receives all these inputs within the three-second time limit, it will enter the Manual Mode for the time assigned. The computer display will flash between “MAN230” (reflecting the time chosen in step 2 of the above procedure) and the current cycle step display for four seconds.

**NOTE: If “NO MAN” is prompted and the normal key sequence for Manual Mode is entered, the computer will display only the remaining cycle time.**

After four seconds, the display will flash between “MANUAL” and the current cycle step display for the remainder of the assigned time.

Manual Mode operation will automatically end when the assigned time elapses. Normal program timing will then resume from the same point in the cycle where the Manual Mode was entered. To exit the Manual Mode and return to normal program timing before the assigned time elapses, press the Start key.

All water fill and spray rinse valves, supplies, heat (if the washer-extractor has reached low water level), and auxiliary outputs can be manually controlled. The heat output requires that only the Heat key be pressed. All other outputs require that two keys be pressed. For example, to turn on the cold fill valve, press the keys Cold and Fill. When an output is on, pressing the same key or keys which caused it to energize will turn it off. Thus, to turn off the cold fill valve, press the keys Cold and Fill once again.

### Auxiliary Connections

The Auxiliary Fill Valve is set up to be connected to a third party reuse water supply only.

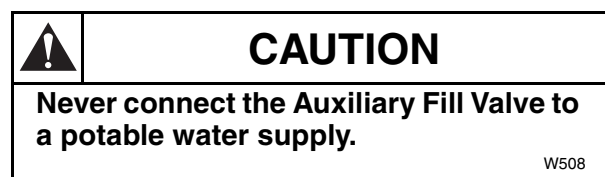

This valve is mounted on the right side of the machine and is equipped with a hose barb on the inlet side. The auxiliary drain line has a normally closed drain valve and exits the left rear of the machine.

## Balance Timing Sequence for Information on Preprogrammed Cycles

Inverter drive balance timing sequence, if active, will occur during a drain step. This prevents machine from reaching a high speed when a poorly balanced load is sensed. Short timing sequence (“S BAL”) and long timing sequence (“L BAL”) are as follows:

1. Control enters drain step (displays “D1,” “Da,” or “Db”) with drain(s) initially closed. The first phase of drain step takes less than 10 seconds (control verifies balance system type and performs a short sequence to reset any possible drive conditions that can be reset).
2. Machine runs at regular wash speed forward (not 1/2 wash speed) for a total of 10 seconds if “S BAL” or for a total of 15 seconds if “L BAL.”
3. Machine runs at distribution speed for a total of 15 seconds if “S BAL” or for 20 seconds if “L BAL.”
4. Drain(s) open.
5. Control waits for empty condition.
6. After empty condition appears, control waits for 20 seconds before checking the balance signal if “S BAL” or 30 seconds if “L BAL.” Drain 5 stays in this step for 2 seconds and ignores out-of-balance conditions. Drain 5 MUST be followed by a medium spin speed or spray rinse.
7. Control then monitors balance signal from inverter drive for up to 5 seconds. If balance is okay, control proceeds to next step after drain when 5-second time expires. If balance is not okay at any point during this 5 seconds, control will return to regular wash speed for 10 seconds if “S BAL” or for 15 seconds if “L BAL.” Control will repeat timing sequence, beginning with step 3 above, in an attempt to balance load.

For models with Firmware ID Code ARWC01 and greater, the inverter drive uses a special signaling sequence that will limit the maximum spin speed based on the load balance. If the spin speed is decreased from the programmed spin speed from being out-of-balance, display flashes the reduced spin speed and the programmed spin speed.

The following are possible spin speeds:

- MS – speed limited to medium speed
- H1 – speed limited to H1 spin speed
- H2 – speed limited to H2 spin speed
- H3 – speed limited to step below maximum spin speed

## Programming

**NOTE: Any time machine goes from wash speed to spin speed, a drain step *must be programmed* prior to high speed step to allow load balancing. Any spin speed steps for which a drain step has not occurred will be skipped.**

**NOTE: For steps Drain 1, a, b or 5 ONLY, control will not advance through a drain step due to balance procedure. Control will neither start in a spin step nor allow any spin step(s) for which proper balancing has not occurred.**

## Cycle Programming

### Displaying a Cycle in Memory

1. Enter Program Mode. Refer to *Entering Program Mode* section.
2. Press the Edit Cycle keypad on the keypad. The display will read “DCYC00.”
3. Press the two-digit code to display the desired cycle number: For example, press 2 keypad and then 5 keypad to select cycle 25. The display will read “DCYC25.”
4. Press Enter keypad. The control will search for cycle information for this cycle number.

*If no cycle information exists, the control will flash “NCYC25” followed by “ADD?” To add this cycle, press Enter keypad and proceed to add the desired steps for this cycle. Refer to **Step Programming** section for specific programming instructions. If adding this cycle is not desired, press the Clear keypad, and control will then return to the normal programming mode.*

5. If cycle information *does* exist for cycle 25, control will display “0425,” for example, to indicate that cycle 25 has been run four times. To clear count (reset it to zero), press 0 keypad. Display will then show “0025.”  
  
If clearing the count is not necessary or if it has just been cleared, press Enter keypad. Control will display “TH0125,” indicating first step of cycle 25.
6. Press Advance keypad to move to next step of the cycle. To access further information pertaining to each step (for example, temperature and/or time), press Enter keypad. If display shows a temperature, press Enter keypad again to display time. Press Enter keypad once more to advance to next step.
7. At cycle end, control will display “END-25” for two seconds and return to normal programming mode.
8. Return Program Mode switch to RUN position and remove key.

**NOTE: Never press Clear keypad while displaying a cycle in memory except to edit or delete a step.**

## Editing a Cycle

To edit a cycle in memory or to change, add, or delete a step:

1. Enter Program Mode. Refer to *Entering Program Mode* section.
2. Press Edit Cycle keypad. Display will read “DCYC00.”
3. Press two-digit code for cycle requiring editing: For example, press 2 keypad and then 5 keypad to select cycle 25.
4. Press Enter keypad. Control will search for cycle information for this cycle.

*If no cycle information exists*, control will flash “NCYC25” followed by “ADD?” To add this cycle, press Enter keypad and proceed to add the desired steps for this cycle. Refer to *Step Programming* section for specific programming instructions. If adding this cycle is *not* desired, press Clear keypad. Control will then return to normal programming mode.

5. If cycle information *does* exist for cycle 25, control will display “0425,” for example, to indicate that cycle 25 has been run four times. To clear count (reset it to zero), press 0 keypad. Display will read “0025.”

If clearing count is not necessary or if it has just been cleared, press Enter keypad. Control will display “HH0125,” indicating first step of cycle 25.

6. Press Advance keypad to move to next step of cycle.
7. Press 0 keypad to back up to previous step.
8. To access further information about each step (for example, temperature and/or time), press Enter keypad.  
If display shows a temperature, press Enter keypad again to display time.
9. Press Enter keypad once more to advance to next step.

**NOTE: At any time, programmer can put the Program Mode switch in RUN position, and control will return to normal running mode, provided all data for last step edited is entered.**

10. To change a step within cycle, press Clear keypad *once* while control is displaying step to be edited. Enter new step, using same procedure for adding a step to a new cycle. Refer to *Step Programming*.

**NOTE: If, after Clear keypad is pressed, it is decided that clearing step is *not* desired, press Edit Cycle keypad to restore step. (This will work only if a step identification was displayed before pressing Clear keypad. At other points in the step—such as a time or temperature display—this restoration effort will not work.)**

11. To change time assigned to a step, press Clear keypad *once* while control is displaying unwanted time.
12. To add a step within cycle, press Add Step keypad. The step will be added into the cycle after the step presently displayed.

Control will check to see if enough cycle memory is left in the cycle to add a step. (Each cycle may contain up to 51 steps.)

If cycle memory for this cycle is full, control will display “CYFULL” for two seconds and return to displaying the previous step. If control can add a step, the new step number will be displayed and the step may be added (as when adding a step to a new cycle). Refer to *Step Programming* section.

13. To delete a step within a cycle, press Clear keypad while control is displaying the step to be deleted. Press Clear keypad again: display will read “WAIT” while it is deleting the step.  
Control will display the next step in the cycle, using the same step number as the deleted step.

**NOTE: If Add Cycle keypad is pressed by mistake instead of Edit Cycle keypad when the cycle number to be edited is entered, display will flash “EXISTS” and “EDIT?” To recover, press Enter keypad, and control will change to Edit Mode.**

## Programming

### Erasing a Cycle in Memory

**IMPORTANT:** Erasing a cycle in memory is not reversible.

1. Enter Program Mode. Refer to *Entering Program Mode* section.
2. Press Erase Cycle keypad. Display will read “ECYC00.”
3. Press two-digit code for cycle number to be erased. Display will read “ECYC25” if cycle 25 is selected.
4. Press Enter keypad. Display will read “WAIT” while it is erasing the cycle. Display will return to “CYC00.” If there is no such cycle number in memory, display will read “NCYC25.” To *not* erase a cycle, press Clear keypad *before* pressing Enter keypad. Display will return to “CYC.”
5. Return Program Mode switch to RUN position and remove key.

### Programming a Wet Clean Cycle

None of the standard 39 preprogrammed cycles includes wet clean steps. Refer to *Sample Cycles for Wet Clean* section in *Operation Manual* to sample wet clean cycle.

**IMPORTANT:** Use of *any* wet clean cycle prior to approval by a wet clean chemical manufacturer’s representative can result in damage to garments.

## Step Programming

### Programming a Fill without Spray

This process is used in temperature-controlled fill steps. Water is added through the sump only.

To program a fill without spray, program a cold, hot, or warm fill to level as in a normal fill step; however, instead of pressing Enter keypad after selecting level, press Auxiliary keypad. Control will display a lower case “c,” “h,” or “w,” instead of usual upper case “C,” “H,” or “W.” Press Enter keypad and program time.

**NOTE:** A fill without spray is programmable in other fills.

### Programming a Fill Temperature

Table 4 lists the required procedures to produce specific results.

Table 4 shows that when HIGH water level is programmed, display indicator is “H.” When MEDIUM level is programmed, display indicator is “M.” When LOW level is programmed, display indicator is “L.” When OVERFLOW is programmed, display indicator is “O.”

When Warm keypad is pressed, next keypad pressed will be another temperature keypad (Hot, Cold, or Warm) *before* selecting level. Exceptions to this will be when RINSE or FLUSH steps are used: they require no level commands, and water is added through door spray nozzle only.

Each time Warm keypad is pressed, one hot and one cold water valve is turned on. The machine is equipped with four water valves (two fill and two spray). Pressing the Warm keypad twice will turn on *all four* valves and reduce fill times.



Use the following procedure to program a fill to a specific temperature:

1. Control must be in Program Mode (refer to *Entering Program Mode* section). The cycle programming sequence must be ready for the fill temperature (refer to *Editing a Cycle* section).
2. Press Cold keypad. If this is the second step of cycle 25, for example, display will read “C-0225.”
3. Press keypad representing desired water level (Low, Medium, High, or Over). If High is pressed, for example, display will read “CH0225.”
4. Press Heat keypad (5). Display will read either “080F25” or “025C25,” depending on whether Fahrenheit or Centigrade is prompted.

Enter desired fill temperature. Three digits must be entered. If desired temperature is less than 100 degrees, the first digit must be 0. If 100 degrees Fahrenheit is selected, display will read “100F25.”

The valid temperature range is 80–200 degrees Fahrenheit and 25–93 degrees Centigrade. Control will not accept temperatures out of this range. (Fill temperatures possible are governed by temperature of available hot water.)

5. Set Enter keypad. Display will read “M---S.”
6. Enter maximum time to be allowed for reaching the fill level in minutes and seconds.
7. Press Enter keypad, and go to next step in cycle. Another step may be programmed or Program Mode may be exited.

Control will attempt to maintain temperature within a margin of plus or minus 5 degrees of target fill temperature during such a step.

Fill Temperature Programming		
Keypads Pressed	Display	Valves Operating
Hot + Low + Enter	“HL”	1 Hot Fill and 1 Hot Spray
Hot + Med + Enter	“HM”	1 Hot Fill and 1 Hot Spray
Hot + High + Enter	“HH”	1 Hot Fill and 1 Hot Spray
Warm + Warm + Low + Enter	“WL”	Both Hot and Both Cold
Warm + Hot + Low + Enter	“WL”	Both Hot and 1 Cold Fill
Warm + Cold + Low + Enter	“WL”	1 Hot Fill and Both Cold
Cold + Low + Enter	“CL”	1 Cold Fill and 1 Cold Spray
Cold + Med + Enter	“CM”	1 Cold Fill and 1 Cold Spray
Cold + High + Enter	“CH”	1 Cold Fill and 1 Cold Spray
Hot + Overflow + Enter	“HO”	1 Hot Fill to Overflow
Cold + Overflow + Enter	“CO”	1 Cold Fill to Overflow
Warm + Warm + Overflow + Enter	“WO”	Both Hot and Both Cold to Overflow
In addition to standard fill temperatures, computer-controlled fill or overflow to a specific temperature is available.		

Table 4

## Programming

### Programming a Supply Step – Models with 8 Supplies

The WE-6 control is capable of controlling 8 separate supplies, and up to 31 various combinations of the 8 supplies. Refer to *Table 5* for a listing of the energized supply compartments represented by each display code. Supplies are divided into 2 separate banks of 4 supplies each. *Supply 5* acts as a switching function between the 2 banks of supplies and is counted as one of 31 combinations, as it can be programmed alone for special applications.

The LED display will indicate the combination of supply compartments that will energize for that particular supply. For example, when a Supply 3 (first supply bank, third supply signal) is programmed, display reads “S3nncc,” with “nn” representing step number and “cc” representing cycle number. Supply 3 flushes supply compartment 3. When Supply 7 (second supply bank, second supply signal) is selected, display reads “S7nncc.” Refer to *Table 5* for a full explanation of 8 available supplies.

#### *Programming a Supply in First Supply Bank*

1. Control must be in Program Mode (refer to *Entering Program Mode* section). Cycle programming sequence must be ready for supply step. Refer to *Editing a Cycle* section.
2. Press Supply keypad (6). Display will read “S-nncc.” Press 1, 2, 3, or 4 keypad, whichever corresponds to the appropriate supply valve to be turned on. If 4 keypad is pressed, for example, display will read “S4nncc.”
3. Press Enter keypad. Display will read “M---S.” Enter the time in minutes and seconds that supply injection should last.
4. Press Enter keypad and go to next step of cycle. Another step may be programmed or Program Mode may be exited.

#### *Programming a Supply in Second Supply Bank*

**NOTE: To energize second bank of supplies, press Supply keypad and 5 keypad. *Supply 5* serves only as a switching function between the first and second supply banks, and is not an actual supply output.**

1. Control must be in Program Mode (refer to *Entering Program Mode* section). Cycle programming sequence must be ready for supply step. Refer to *Editing a Cycle* section.
2. Press Supply keypad (6) followed by 5 keypad to switch from first supply bank to second supply bank. Display will read “S5nncc.” Press 1, 2, 3, or 4 keypad, whichever corresponds to appropriate supply valve to be turned on. Pressing 1 keypad will energize first supply signal of second supply bank, representing supply 6. Display will read “S6nncc.”

Supply Designations					
Supply Number	Display	Keypad Combination	Supply Bank Relation	Decal Label	Compartment Flush
<b>First Supply Bank</b>					
Supply 1	“S1nncc” <sup>†</sup>	Supply keypad followed by 1 keypad	First supply signal, first supply bank	Supply 1	1
Supply 2	“S2nncc” <sup>†</sup>	Supply keypad followed by 2 keypad	Second supply signal, first supply bank	Supply 2	2
Supply 3	“S3nncc” <sup>†</sup>	Supply keypad followed by 3 keypad	Third supply signal, first supply bank	Supply 3	3
Supply 4	“S4nncc” <sup>†</sup>	Supply keypad followed by 4 keypad	Fourth supply signal, first supply bank	Supply 4	4 and 5
<b>Second Supply Bank</b>					
Supply 6	“S6nncc” <sup>†</sup>	Supply keypad followed by 5 keypad*, then 1 keypad	First supply signal, second supply bank	Supply 6	1
Supply 7	“S7nncc” <sup>†</sup>	Supply keypad followed by 5 keypad*, then 2 keypad	Second supply signal, second supply bank	Supply 7	2
Supply 8	“S8nncc” <sup>†</sup>	Supply keypad followed by 5 keypad*, then 3 keypad	Third supply signal, second supply bank	Supply 8	3
Supply 9	“S9nncc” <sup>†</sup>	Supply keypad followed by 5 keypad*, then 4 keypad	Fourth supply signal, second supply bank	Supply 9	4 and 5
<sup>†</sup> In these examples “nn” represents step number, and “cc” represents cycle number. * Supply 5 acts as a switching function between first and second supply banks.					

Table 5

## Programming

To program which supply compartments are flushed for a particular supply, perform the following steps:

1. Advance to supply step to be changed (Supply 3, for example).
2. Display will read "S3nncc."
3. Press Clear/Stop keypad (6) to clear programmed supply compartments to be flushed from WE-6 control.
4. Press Supply keypad (6) and 3 keypad again to program a flush of compartment 3, for example.
5. Display will read "S3nncc."
6. Press 1 keypad to program a flush of compartment 1, for example.
7. Display will read "SBnncc," with B representing code from both compartments 1 and 3. Refer to *Table 6*.

**NOTE: The order in which each compartment is selected is not important.**

8. Press Enter keypad. Display will now read "M---S." Enter time in minutes and seconds that supply injection should last.
9. Press Enter keypad. Another step may be programmed or Program Mode may be exited.

Supply Display Codes (8 supplies)		
Code	Supply Number 0 = Supply Off X = Supply On	
	5 4 3 2 1	
Supply Bank One	1	0 0 0 0 X
	2	0 0 0 X 0
	A	0 0 0 X X
	3	0 0 X 0 0
	B	0 0 X 0 X
	C	0 0 X X 0
	D	0 0 X X X
	4	0 X 0 0 0
	E	0 X 0 0 X
	F	0 X 0 X 0
	H	0 X 0 X X
	I	0 X X 0 0
	J	0 X X 0 X
Supply Bank Two	L	0 X X X 0
	M	0 X X X X
	5	X 0 0 0 0
	6	X 0 0 0 X
	7	X 0 0 X 0
	N	X 0 0 X X
	8	X 0 X 0 0
	O	X 0 X 0 X
	P	X 0 X X 0
	Q	X 0 X X X
	9	X X 0 0 0
	R	X X 0 0 X
	S	X X 0 X 0
T	X X 0 X X	
U	X X X 0 0	
V	X X X 0 X	
W	X X X X 0	
X	X X X X X	

Table 6

## Programming Heat

**NOTE: A fill step must be programmed prior to a heat step.**

1. To program auxiliary heat (either electric or steam), control must be in Program Mode (refer to *Entering Program Mode* section), and cycle programming sequence must be ready for heat step. Refer to *Editing a Cycle* section.
2. Press Heat keypad. Display will read “HTncc.”
3. Press Enter keypad (5). Display will read either “080Fnn” or “025Cnn,”(depending on whether Fahrenheit or Centigrade is prompted).
4. Enter final temperature desired. Three digits must be entered for temperature. If desired temperature is less than 100 degrees, the first digit should be 0. The valid temperature range is 80–200 degrees Fahrenheit and 25–93 degrees Centigrade.
5. Press Enter keypad. Display will read “H---M.” Enter maximum time in hours and minutes for water to reach desired temperature.
6. Press Enter keypad and go to next step in cycle. Another step may be programmed or Program Mode may be exited.

## Programming a Wash Step

1. Control must be in Program Mode (refer to *Entering Program Mode* section). Cycle programming sequence must be ready for next step. Refer to *Entering Program Mode* section.
2. Press Wash keypad (4). Refer to *Editing a Cycle* section. Display will read “W-nncc.”
3. Press number keypad (from 1 to 7) that corresponds to desired wash step listed in *Table 7*.

Wash	Description
1	18 seconds forward, pause 3 seconds; 18 seconds reverse, pause 3 seconds; repeat
2	3 seconds forward, pause 27 seconds; 3 seconds reverse, pause 27 seconds; repeat
3	No agitation
4	10 seconds forward, pause 20 seconds; 10 seconds reverse, pause 20 seconds; repeat
5	Agitation is the same as Wash 1 or most recent. Refer to <i>Programming a Wash 5 Thermal Cool-Down</i> section for programming cool down time.
6	4 seconds forward, pause 56 seconds; 4 seconds reverse, pause 56 seconds; repeat
7*	No agitation, drain open (no automatic refilling)
<p><b>NOTE: In all wash steps except Wash drain, machine will automatically refill to most recent water level (if any), and drain will be closed.</b></p> <p>* A wash drain step should only be programmed when it is followed by a non-spin step (i.e., fill step).</p>	

Table 7

## Programming

4. If Wash 1 is chosen, the no-reverse option may be selected. Refer to **Programming No Reversing** section for additional information. The no-reverse option must be selected at *this* point in step programming. Press No Reverse keypad while display reads “W1nccc.”

Control will return to normal reversing action when this step is complete.

5. Press Enter keypad, and display will read “M---S.” Assign wash step time in minutes and seconds.
6. On machines equipped with optional auxiliary heat (steam or electric), it is possible to program a wash step with a temperature step. Machine will perform programmed wash at the temperature programmed during wash step.

To program a wash with a specific temperature, use the following procedure:

- a. After step 3 of **Programming a Wash Step** section, press Heat keypad (5) *before* pressing Enter keypad. Display will read either “080Fcc” or “025Ccc,” depending on whether Fahrenheit or Centigrade is prompted.
  - b. Enter desired temperature for machine to maintain during wash step.  
Three digits must be entered for temperature. If desired temperature is less than 100 degrees, first digit must be 0. Valid temperature range is 80–200 degrees Fahrenheit and 25–93 degrees Centigrade.
  - c. Press Enter keypad. Display will read “M---S”. Assign step time in minutes and seconds.
  - d. Press Enter keypad and go to next step in cycle. Another step may be programmed or Program Mode may be exited.
7. Press Enter keypad. Another step may be programmed or Program Mode may be exited.

## Programming a Wash 5 Thermal Cool-Down

After programming a heat step, a temperature-controlled thermal cool-down to gradually reduce temperature of load and prevent fiber shock from sudden cool-down may be programmed.

When programmed time for step expires, control will advance to next step regardless of whether or not cool-down temperature has been reached. If cool-down temperature is reached before time expires, control will advance to next step.

During cool-down, drain will remain closed and *water will exit through overflow connection*. Cylinder will rotate in a normal reversing mode as during a Wash 1 step.

Use the following procedure to program thermal cool-down. (Do *not* program a drain step before Wash 5 step.)

1. The control must be in Program Mode (refer to **Entering Program Mode** section) and a heat step must be created and entered to continue.
2. Press Wash keypad (5) and then 5 keypad. Display will read “W5nccc.”
3. Press Enter keypad. Display will read either “080Fcc” or “025Ccc,” depending on whether Centigrade or Fahrenheit is prompted.
4. Enter desired temperature for load to cool down to. Three digits must be used for temperature. If desired target temperature is less than 100 degrees, first digit must be “0.” Valid temperature range is 80–200 degrees Fahrenheit and 25–93 degrees Centigrade. (Cool-down rate will be affected by temperature of cold water available.)
5. When desired cool-down temperature is displayed, press Enter keypad. Display will show “H---M.” Enter maximum time in hours and minutes for control to reach target cool-down temperature.

## Programming a Wash Drain (Wash 7) Step

A wash drain step is a drain step intended ONLY for cases where a wash speed operation follows, such as a fill (operates at wash speed, not spin speed).

1. With control ready to accept new step, press Wash keypad. Display shows “W\_ \_ \_ \_.”
2. Press 7 keypad. Display shows “WDnncc” (nn means step number and cc means cycle number).
3. Press Enter keypad. Display shows “\_m\_ \_S.”
4. Enter desired time.
5. Press Enter keypad. Control is ready for next step.

**NOTE: “EMPTY” alarm will occur at the end of wash drain if machine is not empty. Press Enter keypad to repeat step (same as for Drain 1 “EMPTY” alarm).**

**NOTE: It may be necessary to experiment when determining exact time required to enable control to reach target cool-down temperature. Refer to *Editing a Cycle* section revising Wash 5 step when estimating cool-down time.**

When control performs Wash 5 step, temperature in sump must be greater than target cool-down temperature to prevent control from advancing past Wash 5 step.

6. When desired time is displayed, press Enter keypad. Another step may be programmed or Program Mode may be exited.

## Programming No Reversing

If a no reversing agitation is desired (rotation continuous in one direction), use following procedure:

1. Press Wash keypad. Display will read “W-nncc”.
2. Press either 1 keypad or 2 keypad. Refer to *Table 7*.
3. Press No Reverse keypad for selection desired.
4. Press Enter keypad.

Display will show either “W1nncc” or “W2nncc,” depending on type of agitation selected. Display will not indicate that no-reverse option was selected.

**NOTE: No-reverse option is normally used with Wash 1 steps but may be used with other appropriate functions. No-reverse option may be programmed in wash, supply, heat, and overflow steps. No Reverse keypad must be pressed prior to pressing Enter keypad when programming a step. Refer to *Programming a Wash Step* section.**

## Programming a Soak Step

1. Control must be in Program Mode (refer to *Entering Program Mode*). Cycle programming sequence must be ready for soak step. (Previous step should have been a fill and/or supply step.)
2. Press Soak keypad. Display will read “SKnncc.”

For machines equipped with auxiliary heat (optional steam or electric), it is possible to program a soak-with-temperature step. Machine will soak for time programmed at temperature programmed during soak step.

To program a soak-with-temperature step, continue with the following procedure:

- a. Press Heat keypad. Display will read either “080Fcc” or “025Ccc,” depending on whether Fahrenheit or Centigrade is prompted.
  - b. Enter temperature desired for machine to maintain during soak step. Three digits must be entered for temperature. If desired temperature is less than 100 degrees, first digit should be 0. The valid temperature range is 80–200 degrees Fahrenheit and 25–93 degrees Centigrade.
3. Press Enter keypad. Display will read “H---M.” Assign soak step desired time in hours and minutes. During soak step, no agitation will occur. Maximum soak step time is 9 hours and 99 minutes.
  4. Press Enter keypad and go to next step in cycle. Another step may be programmed or Program Mode may be exited.

## Programming

### Programming a Drain Step

- Control must be in Program Mode (refer to *Entering Program Mode* section). Cycle programming sequence must be ready for drain. Refer to *Editing a Cycle* section.
- Press Drain keypad (0). Display will read “D-nncc.”
- Press 1 keypad for a regular drain to sewer or a floor drain. Display will read “D1nncc.”
- A drain to sewer (floor drain) step may be programmed with a reduced time. Press Drain 5 (i.e., press “5” keypad following “Drain” keypad). “D5nncc” will display. Drain 5 is identical to Drain 1 (without rebalancing attempts). Do not program an H1, H2 or H3 spin after Drain 5.  
  
Drain 1, a, b and 5 steps distribute the load and have certain automatic timing functions. Program these drain steps when a spin step follows a drain operation. Program a wash drain when a non-spin step, such as a fill follows.
- Press Enter keypad. Display will read “M---S.” Enter drain time for machine to empty.

**NOTE: This is an alarm time. Machine should drain in 30 seconds under normal conditions. Recommended drain time is one minute. Drain times of more than one minute are not recommended.**

- Press Enter keypad. Another step may be programmed or Program Mode may be exited.

### Programming a Flush Step

When Flush keypad (4) is pressed, drain will remain open and basket will rotate in slow speed forward only. Water is added only through door spray nozzle.

- Control must be in Program Mode (refer to *Entering Program Mode* section). Cycle programming sequence must be ready for flush step. Refer to *Editing a Cycle* section.
- Press a water temperature keypad. If Cold keypad (1) is pressed, for example, display will read “C-nncc,” etc.
- Press Flush keypad (4). Display will read “CFnncc,” “HFnncc,” or “WFnncc,” depending upon temperature selected.
- Press Enter keypad. Display will read “M---S.” Enter desired flush time in minutes and seconds.
- Press Enter keypad. Another step may be programmed or Program Mode may be exited.

### Programming a Reuse Drain Step with Third Party Water Reuse System

Control does not need to be prompted to run Water Reuse System if Reuse system uses E1 and E2 outputs/relays on fuse board.

**NOTE: Use of E1 and E2, which control 9 volt DC relays, involves the combination in Table 8.**

	E1	E2
Fill from reuse tank (a)	ON	ON
Drain to reuse tank (a)	OFF	ON
* Table only shows when one reuse tank is used (designated tank A).		

Table 8

ON means relay connected to output is energized and voltmeter should read 9 to 11 volts DC. Connect positive lead to +10V and negative lead to E1 or E2 output.

With control in Program Mode, (refer to *Entering a Program Mode* section), display will show “nncc” where “nn” represents step number and “cc” represents cycle number.

- Press Drain keypad (0). Display will show “D-nncc.”
- Press 2 keypad for auxiliary drain. Display will show “Danncc.”
- Press Enter keypad. Display will show “M---S.” Enter desired step time (maximum time allowed for draining through auxiliary drain valve). If machine does not empty in amount of time, control will sound “EMPTY” alarm. Refer to *Programming a Drain Step* section.
- Press Enter keypad. Another step may be programmed or Program Mode may be exited.



## Programming a Fill through Auxiliary Fill Valve with Third Party Water Reuse System

With control in Program Mode (refer to *Entering Program Mode* section), display will show “nncc” where “nn” represents step number and “cc” represents cycle number.

1. Press Auxiliary keypad. Display will show “A-nncc.”
2. Press 6 keypad for auxiliary fill valve. Display will show “a-nncc.”
3. Press Low, Medium, or High keypad to program desired water level. If a fill using auxiliary fill valve to fill to medium water level is selected, for example, display will show “aMnncc.”
4. Press Enter keypad. Display will show “M---S.” Enter desired maximum time to allow for step.
5. Press Enter keypad. Another step may be programmed or Program Mode may be exited.

## Programming a Spin Step

1. Control must be in Program Mode (refer to *Entering Program Mode* section), and cycle programming sequence must be ready for spin step. Refer to *Editing a Cycle* section.
2. Press Medium Speed (8) or High Speed keypad (3). High Speed keypad must be pressed once for high speed spin No. 1, twice for high speed spin No. 2, and three times for high speed spin No. 3. Display will read “MSnncc” for medium speed or “H1nncc” for high speed spin No. 1, “H2nncc” for high speed spin No. 2, or “H3nncc” for high speed spin No. 3. (If High Speed keypad is pressed when display shows “H3nncc,” control will then return to “H1nncc.”)
3. Press Enter keypad. Display will read “M---S.” Enter time in minutes and seconds to spin step.
4. Press Enter keypad. Display will read “SDLY” for *one* second. Display will then change to “0M-00S.”
5. Assign time for spin delay (coast down). Rotation sensor allows for spin delay to be put at 0.

**NOTE: Do not program a Wash 1 step for a shakeout after spin step. If such a step is programmed, control will revert to previous wash step and will fill with water accordingly. Refer to *Stop Routine* section. However, a Wash 1, 2, or 3 step, programmed for ONE second will select stop routine agitation *and* avoid refilling.**

**NOTE: Do not program a “SDLY” time if spin step is followed by another spin. This will cause control to skip all consecutive spins and start next non-spin step.**

**NOTE: Program a drain 1 or a reuse drain step before an H1, H2 or H3 spin to permit full spin speed. Do not program an H3 spin after drain 5, or as a consecutive spin following drain 5. This will result in a less than maximum spin speed. Control defaults to a lower speed spin when an H1, H2 or H3 follows a drain 5. It is recommended to program a drain 5 before a medium spin step or a spray rinse step only.**

## Programming

### Spins

The control allows the user to program consecutive spin steps only if the second spin is set at the same speed or a higher speed. For example, if a cycle contains a H2 spin step, followed by a H1 spin step, the control will skip the H1 spin step because it is a lower speed spin than H2.

### Stop Routine

During the final count down in stop routine, when rotation sensor is activated, control maintains countdown until the machine has stopped rotating. If control does not sense rotation, it defaults to a fixed minimum countdown time. In both cases, a shake out routine follows. The shakeout time is reduced if rotation sensor is working correctly; otherwise, a shakeout time is set at a longer time. At the end of shake-out routine, "STOPxx" displays briefly, then displays "donExx," if there is no rotation. If rotation is sensed, control waits until rotation stops (not showing "done"). When no rotation is sensed, door can be opened.

### Programming a Spray Rinse Step

**NOTE: Programming a medium speed step for 30 seconds immediately before a spray rinse step is recommended.**

When Rinse keypad (5) is pressed, drain will remain open and basket will rotate in medium spin speed. Water is added through door spray nozzle only. To program a spray rinse step, use following procedure:

1. Control must be in Program Mode (refer to *Entering Program Mode* section), and cycle programming sequence must be ready for next step.
2. Press a water temperature keypad. If Cold keypad (1) is pressed, for example, display will read "C-nncc," etc.
3. Press Rinse keypad. Display will read "CRnncc," "HRnncc," or "WRnncc," depending on whether cold, hot, or warm temperature was selected.
4. Press Enter keypad. Display will read "M---S." Enter time in minutes and seconds desired for duration of rinse step.
5. Press Enter keypad. Another step may be programmed or Program Mode may be exited.

**NOTE: If a coast-down delay ("SDLY") is desired after a spray rinse step, program a medium-speed spin step for one second after rinse step. Then program desired coast-down time.**

**NOTE: If there is only a spray rinse, or a medium spin, cycle time can be reduced by programming a drain 5 before the spray rinse or medium spin (instead of drain 1).**

## Auxiliary

Auxiliary No. 1 and Auxiliary No. 2 may be used to control an external buzzer or other device (not supplied with the machine) with a maximum current draw of less than 1/2 amp, if machine is not prompted for wet cleaning.

Auxiliary No. 3 is identified on fuse board as A3 (Signal) and controls built-in buzzer (alarm) mounted on inside wall of control module.

When A3 is programmed, signal will sound continuously for duration of time assigned. The same signal (buzzer) is used by control for an alarm condition, such as a "FILL" or "EMPTY" alarm.

Auxiliary 4 step (extra fill). Press Auxiliary keypad. Display will read "A-nncc." Press 4 keypad. Display will read "R-nncc." Press "low," "medium," or "high" to select low, medium, or high fill level. Display will read "RLnncc," "RMnncc," or "RHnncc" respectively. Press Enter keypad and program step time. Only program this special step if extra fill capability is being used.

Wet Clean 1/2 Wash Speed (Gentle Wash). Wash 1, 2, 4, 5, and 6 agitations can have either normal wash speed or 1/2 wash speed (gentle wash) if control is prompted for wet cleaning ("WET CL") and necessary hardware is installed. To select gentle wash speed, program an Auxiliary 1 step (A1) *before* low-speed step or steps which are to have reduced wash speed. Any time for Auxiliary 1 step may be programmed: 1 second is recommended. Reduced wash speed will be in effect until a drain step is activated or until stop routine is started. Control accomplishes this by leaving the Auxiliary 1 output energized after an Auxiliary 1 step until a drain step is reached.

**NOTE: If "NO WCL" is selected in prompting process, Auxiliary 1 operates as a timed output (remains on for time programmed).**

Recirculation Pump. Control *must* be prompted for "1DRAIN" and "WET CL." Also, a second drain should *not* be connected to the Auxiliary 2 output if recirculation pump is used. However, a second independent drain will operate properly when connected to Auxiliary 2 output *if* control is prompted for "2DRAIN." One machine cannot have both a recirculation pump and a second independent drain.

**NOTE: This is not the same as the "dual drain" option. Dual drain models operate two drains simultaneously. A second independent drain can be programmed to operate independently of the main drain (drain 1) if "2DRAIN" is prompted. This capability would only be used in special applications and is not for use with standard wet cleaning applications. Therefore, drain should be prompted for "1DRAIN," under normal operating conditions.**

If control is prompted for "WET CL", Auxiliary 2 output remains on until a drain step is activated or until stop routine is started. Also, control will turn off Auxiliary 2 output (recirculation pump) upon entering a Wash drain step.

**NOTE: Control precludes operation of recirculation pump if temperature exceeds 160 degrees Fahrenheit (71 degrees Centigrade) for remainder of step in effect at time.**

**NOTE: If "NO WCL" and "1DRAIN" are selected in prompting process, Auxiliary 2 operates as a timed output (remains on for time programmed).**

## Programming

When signal is activated by control to indicate an alarm condition, tone will be pulsating rather than continuous.

1. Control must be in Program Mode. Refer to ***Entering Program Mode*** section. Cycle programming sequence must be ready for auxiliary step. Refer to ***Editing a Cycle*** section.
2. Press Auxiliary keypad. Display will read "A-nncc." Press number keypad-1, 2, 3, 4, or 5- that corresponds to desired auxiliary function:  
  
A1-Auxiliary No. 1  
A2-Auxiliary No. 2  
A3-Signal (SG)  
A4-Fill to level using E1 on control output board. (E1 is a special function ONLY. This step applies only for extra fill capacity. Contact manufacturer for details.)

**NOTE: If washer-extractor has an extra fill capability controlled by E1, it cannot also have water reuse option installed. Also if washer-extractor has water reuse option, it cannot have an extra fill capability. Contact manufacturer for details.**

- A5-Provides agitation, no refill.
3. Display will read "A2nncc," for example, if 2 keypad is pressed.
4. Press Enter keypad. Display will read "M---S." Enter auxiliary step desired time in minutes and seconds.
5. Press Enter keypad and go to next step in cycle.

## Balance Detection

The washer-extractor may be equipped with either a Vibration Switch Detection System or a Vibration Detection System with an Inverter Drive Balance Detection System. All machines of the Design 5 series or lower will have only the vibration switch detection system. All machines of the Design 6 series or greater will have both the vibration switch and inverter drive balance detection systems.

## Balance Switch Detection

The vibration switch detection system utilizes a micro-switch mounted between the faces of the A-frame (UW60 – UW125 models) or mounted on the lower left corner of the frame (UW150 models) to signal the WE-6 computer when the load imbalance is too great for high extract speeds.

The inverter drive will monitor load imbalance conditions during the distribution speed step, and if the load is sufficiently out-of-balance, the computer will attempt to re-distribute the load again. The computer will attempt to balance the load in this manner up to two more times for a total of three attempts. If the inverter drive continues to detect an out-of-balance load on the third attempt, the computer display will illuminate the out-of-balance LED indicator, and the computer will determine the maximum safe spin speed up to a maximum speed of 235g. In addition, during any spin speed step, if the vibration safety switch detects a severe imbalance condition, due to improper installation or improper loading of the washer, the computer will abort the remaining portion of the cycle and stop the machine. The display will flash “BAL DR” while aborting the cycle until the door has been opened.

**NOTE: The computer cannot advance through a drain step, nor will the computer allow starting a cycle in a spray rinse or spin step.**

**NOTE: A drain step must be programmed prior to a high speed step to allow for inverter drive balance detection. Otherwise, spin steps will be skipped by the computer.**

## Simulator Operation and Program Transfer

### Simulator Operation

The WE-6 simulator is an optional accessory to the WE-6 microcomputer-controlled UWPV washer-extractor. See Figure 6. *When the simulator is first energized, the simulator display will show the program (ROM) identification code for five seconds.*

**NOTE: Cycles programmed for rigid-mount UWPV machines are not compatible with cycles programmed for freestanding UF models and vice versa. Also, cycles for UWPV machines are not compatible with cycles for UWP machines. DO NOT transfer cycles from one of these models to another.**

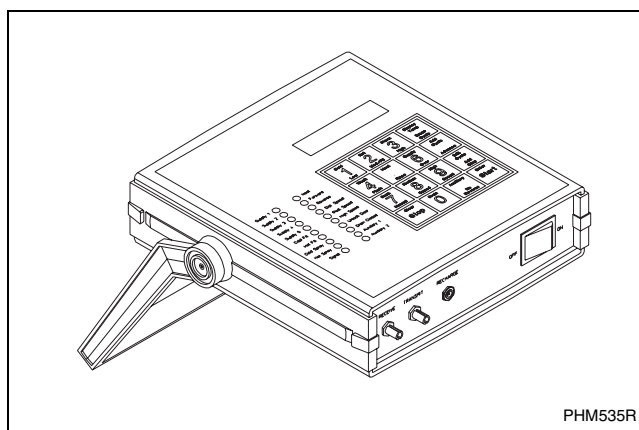

Figure 5

All programming instructions in this manual apply to the simulator as well.

The simulator is a hand-held unit which serves more than one purpose:

- The simulator's primary purpose is to preprogram cycles for transfer to the washer-extractor and to transfer program cycles between the washer-extractor and the simulator in either direction.
- As an instructional aid, the simulator can be used for teaching programming techniques to individuals unfamiliar with the UWPV WE-6 microcomputer.

## Programming

The keypad and LED display are mounted on the top of the simulator. The ON/OFF rocker switch is located on the front end-panel.

The handle pivots to serve as a stand when using the simulator on a table. To pivot the handles, grasp them at the point of attachment to the main housing and gradually pull the handle sides outward until the ends disengage from the splined mounting holes. Pivot the handles to the desired position and release.

The simulator is battery powered and is supplied with an AC transformer which produces 12VDC at 500mA to recharge the battery pack from a 120V wall plug.

- The transformer is plugged into the power jack marked RECHARGE on the front end-panel of the simulator. The battery pack will be charged only while the simulator is turned *on* and is operating from the transformer.
- A fully charged battery pack will give about 3 hours of operation before recharging is necessary. Allow about 24 hours to fully recharge the battery pack with the transformer.
- The simulator battery pack contains NiCad batteries. These batteries will develop a “memory” according to length of time used. For example, if the simulator is habitually used for only one hour before recharging the batteries, the battery pack will eventually retain this habit and will power the simulator for only one hour before charging is required.
- When replacing the battery, use an exact NiCad replacement unit. **Failure to do so will result in damage to the simulator.**

The WE-6 simulator and the WE-6 microcomputer are capable of storing and running up to 39 cycles, each limited to 51 steps.

- The computer will not accept cycle numbers higher than 39.
- If an attempt is made to add a step to a cycle that already contains 51 steps, the computer will display “CYFULL” and refuse additional steps.

The front end-panel of the simulator holds the RECEIVE and TRANSMIT ports for the optic cables used in program transfers.

- When transferring cycles from simulator to computer or computer to simulator, the colored plugs on the ends of the optic cables must match the colors of the ports on the simulator and on the washer-extractor’s control module (gray to gray, blue to blue).

- If a mistake is made connecting the cables, the display will flash “COMM” and “ERROR” when the **Enter** key is pressed during the last step of the cycle transfer process.

On the rear end-panel of the simulator are 6 toggle switches used to simulate various normal operations of the washer-extractor. Refer to *Figure 6*. These 6 switches simulate or control the Program/Run Modes, LOW LEVEL, MEDIUM LEVEL, HIGH LEVEL, DOOR OPEN/DOOR CLOSED, and BALANCE.

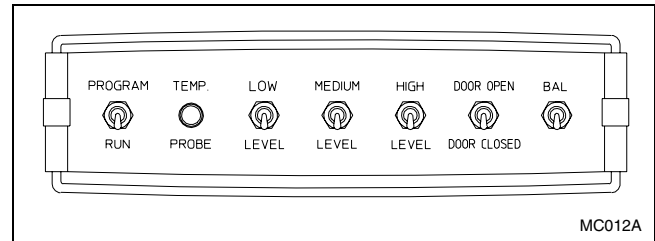

Figure 6

All the switches must be in the *down* position to simulate a machine at rest.

- If the PROGRAM/RUN switch is in the *up* position, the simulator is placed in the Program Mode.
- If the LOW LEVEL switch is in the *up* position, a low level water fill is simulated and the appropriate LED on the display is illuminated. The MEDIUM LEVEL and HIGH LEVEL switches operate similarly.
- When a cycle programmed in the simulator is running, the LEVEL switches must be activated at the appropriate times in the cycle to indicate to the computer that the levels have been reached and that the machine is empty.
- If the DOOR OPEN/DOOR CLOSED switch is flipped to the *up* position (DOOR OPEN) while a cycle is running, the “DOOR” alarm will be displayed.
- If the BALANCE switch is in the *up* position during the spin step or drain step of a cycle, an out-of-balance condition is indicated to the computer. (See Balance Detection in the Operation section of this manual in regard to the drain step.)

The temperature probe (located on the rear end-panel of the simulator) simulates sump temperature.

## Transferring All Cycles from Computer to Simulator

All keypad commands will be entered with the simulator keypad.

Use the following procedure to transfer all cycles contained in the memory of the computer to the simulator. (Transferring 39 cycles takes about 6 seconds.)

1. Connect the fiber optic cables between the simulator and the computer. Verify that the colored plugs on the ends of the optic cables match the colors of the ports on the simulator and on the washer-extractor's control module (gray to gray, blue to blue).
2. Place *both* the simulator and the computer in the Program Mode. The display on both will read "CYC00."
3. Press the **0** key. The display will read "WRITE?"
4. Press the **0** key again. The display will change to "READ?"
5. Press the **Enter** key. The display will read "ALL."
6. Press the **Enter** key again. The simulator display will flash "RECV" and "ALL" alternately. The computer display will flash "SEND" and "ALL" alternately.

When the two displays stop flashing, the transfer is complete.

## Transferring One Cycle from Computer to Simulator

All keypad commands will be entered with the simulator keypad.

Use the following procedure to transfer one cycle contained in the memory of the computer to the simulator. (Transferring 1 cycle takes less than 1 second.)

1. Connect the fiber optic cables between the simulator and the computer. Verify that the colored plugs on the ends of the optic cables match the colors of the ports on the simulator and on the washer-extractor's control module (gray to gray, blue to blue).
2. Place *both* the simulator and the computer in the Program Mode. The display on both will read "CYC00."
3. Press the **0** key. The display will read "WRITE?"

4. Press the **0** key again. The display will change to "READ?"
5. Press the **Enter** key. The display will read "ALL."
6. Press the **0** key. The display will read "CYC."
7. Press the **Enter** key. The display will read "RCYC00."

Now press the 2-digit code for the desired cycle number from the computer.

8. Press the **Enter** key. The display will read "WCYCcc."
9. Press the **Enter** key. The simulator display will flash "RECV" and "CYC" alternately. The computer display will flash "SEND" and "CYC" alternately.

When the two displays stop flashing, the transfer is complete.

## Transferring All Cycles from Simulator to Computer

All keypad commands will be entered with the simulator keypad.

Use the following procedure to transfer all cycles contained in the memory of the simulator to the computer. (Transferring 39 cycles takes about 6 seconds.)

1. Connect the fiber optic cables between the simulator and the computer. Verify that the colored plugs on the ends of the optic cables match the colors of the ports on the simulator and on the washer-extractor's control module (gray to gray, blue to blue).
2. Place *both* the simulator and the computer in the Program Mode. The display on both will read "CYC00."
3. Press the **0** key. The display will read "WRITE?"
4. Press the **Enter** key. The display will read "ALL."
5. Press the **Enter** key again. The simulator display will flash "SEND" and "ALL" alternately. The computer display will flash "RECV" and "ALL" alternately.

When the two displays stop flashing, the transfer is complete.

## Programming

### Transferring One Cycle from Simulator to Computer

All keypad commands will be entered with the simulator keypad.

Use the following procedure to transfer one cycle contained in the memory of the simulator to the computer. (Transferring 1 cycle takes less than 1 second.)

1. Connect the fiber optic cables between the simulator and the computer. Verify that the colored plugs on the ends of the optic cables match the colors of the ports on the simulator and on the washer-extractor's control module (gray to gray, blue to blue).
2. Place *both* the simulator and the computer in the Program Mode. The display on both will read "CYC00."
3. Press the **0** key. The display will read "WRITE?"
4. Press the **Enter** key. The display will read "ALL."
5. Press the **0** key. The display will read "CYC00."
6. Press the **Enter** key. The display will read "RCYC00."

Now press the 2-digit code for the desired cycle number from the simulator.

7. Press the **Enter** key. The display will read "WCYCcc."

Now press the 2-digit code for the desired cycle number under which the cycle should be saved in the computer.

8. Press the **Enter** key. The simulator display will flash "SEND" and "CYC" alternately. The computer display will flash "RECV" and "CYC" alternately.

When the two displays stop flashing, the transfer is complete.

### Preprogrammed Cycles

This section lists 39 preprogrammed (ready-to-use) cycles. To run a cycle, first make certain that control is in Run Mode. Enter two-digit code for desired cycle, and press Start keypad

Test Cycle 39 (standard listing) is the last of 39 preprogrammed cycles. This cycle is used to verify proper operation of machine.

Any of these 39 cycles may be erased and replaced by new cycles. As shown earlier in this section of the manual, cycles may also be edited and revised to match a particular application's specific needs. Thirty-seven of the preprogrammed cycles use high speed spin No. 3 (maximum G force) for final extract.

The following prompts are set at factory:

- Degrees F
- One drain
- Advance enabled
- Manual Mode enabled
- Wet clean disabled
- "S BAL" (if 60 model or smaller)
- "L BAL" (if 80 model or larger)
- Machine Model Size (depends on capacity)

**NOTE: Machine model size prompt must be set correctly to ensure proper operation and to prevent damage to controls.**

**NOTE: Machine size can be found on serial decal of machine. Example: UW60PVQU50001.**

At power up, when display stops flashing "POWER/WAIT;" if display shows "SET UP;" model size must be entered. Enter Program Mode and select machine model size. Step to end of prompts and exit. This step **MUST** be performed for machine to run.



## Cycle Categories

01 Chemical Supply Setup

### *Hotels and Motels*

- 02 Sheets, light soil, cotton/poly blends
- 03 Sheets, light soil, no bleach, cotton/poly blends
- 04 Towels, light soil, cotton
- 05 Towels, light soil, no bleach, cotton
- 06 Sheets, medium soil, cotton/poly blends
- 07 Towels, medium soil, cotton
- 08 Blankets, spreads, no bleach
- 09 Blankets, spreads, cold water
- 10 Towels, heavy soil, cotton
- 11 Rinse and Spin only

### *Healthcare*

- 12 Sheets, light soil, cotton/poly blends
- 13 Towels, light soil, cotton
- 14 Sheets, heavy soil, cotton/poly blends
- 15 Towels, heavy soil, cotton
- 16 Thermal blankets, bleach, cotton
- 17 Diapers, pads, heavy soil, cotton
- 18 Personals, bleach
- 19 Personals, no bleach

### *Restaurants*

- 20 Pads, polyester
- 21 Table napery, bleach, starch, iron
- 22 Table napery, bleach, no iron
- 23 Table napery, colors, starch, iron
- 24 Table napery, colors, no iron
- 25 Visa table napery, bleach, starch, iron
- 26 Visa table napery, bleach, no iron
- 27 Visa table napery, colors, starch, iron
- 28 Visa table napery, colors, no iron

### *Shirt Laundries*

- 29 Shirts, colors, no bleach, starch
- 30 Shirts, bleach, starch
- 31 Shirts, colored, no bleach, no starch
- 32 Shirts, no bleach, no starch, delicates
- 33 Starch, extract only

### *Formulas Common to All Markets*

- 34 Uniforms, with bleach
- 35 Uniforms, without bleach
- 36 Rags/housekeeping, heavy soil
- 37 Rags/kitchen, mops
- 38 Rewash/reclaim
- 39 Test

## Standard Supply Legend

Supplies are shown by number in cycle charts. *Table 9* correlates the supply number with the supply as it is represented in cycle charts:

Standard Supply Legend	
Supply Number	Supply Description
1	Detergent
2	Bleach
3	Sour
4	Softener
5	Specialty

Table 9

## Programming

### Standard Cycle Charts

<b>Cycle 01</b> <b>Formulas Common to All Markets</b> <b>(Chemical Supply Setup)</b>		
Step	Description	Min:sec
1	Warm Fill to Low Level	5:00
2	Supply 1	2:00
3	Supply 2	2:00
4	Supply 3	2:00
5	Supply 4	2:00
6	Supply 5	2:00
7	Wash 1	0:30
8	Wash Drain	0:30

**NOTE:** Cycle shown is intended for setup of supplies with a 5 supply system. If machine is equipped with 8 supplies, refer to *Programming a Supply Step – Models with 8 Supplies*. As extra supplies are normally controlled by bank 2, program supplies 6, 7, 8, and 9.

<b>Cycle 02</b> <b>Hotels and Motels</b> <b>(Sheets, light soil, cotton/poly blends)</b>		
Step	Description	Min:sec
1	Hot Fill to Low Level	5:00
2	Supply 1 and 2 (Display: “SA”)	0:45
3	Wash 1	7:00
4	Wash Drain	0:30
5	Hot Fill to High Level	5:00
6	Wash 1	2:00
7	Drain 5	1:00
8	Warm Spray Rinse	2:00
9	Medium Spin (SDLY 0:15)	0:01
10	100°F (38°C) Fill to Low Level	5:00
11	Supply 3 and 4 (Display: “SI”)	0:30
12	Wash 1	4:00
13	Drain 1	1:00
14	High Spin 3 (SDLY 0:00)	2:00

<b>Cycle 03 Hotels and Motels (Sheets, light soil, no bleach, cotton/poly blends)</b>		
<b>Step</b>	<b>Description</b>	<b>Min:sec</b>
1	Hot Fill to Low Level	5:00
2	Supply 1	0:45
3	Wash 1	7:00
4	Wash Drain	0:30
5	Hot Fill to High Level	5:00
6	Wash 1	2:00
7	Drain 5	1:00
8	Warm Spray Rinse	2:00
9	Medium Spin (SDLY 0:15)	0:01
10	100°F (38°C) Fill to Low Level	5:00
11	Supply 3 and 4 (Display: "SI")	0:30
12	Wash 1	4:00
13	Drain 1	1:00
14	High Spin 3 (SDLY 0:45)	2:00

<b>Cycle 04 Hotels and Motels (Towels, light soil, cotton)</b>		
<b>Step</b>	<b>Description</b>	<b>Min:sec</b>
1	Hot Fill to Low Level	5:00
2	Supply 1 and 2 (Display: "SA")	0:45
3	Wash 1	7:00
4	Wash Drain	0:30
5	Hot Fill to High Level	5:00
6	Wash 1	2:00
7	Drain 5	1:00
8	Warm Spray Rinse	2:00
9	Medium Spin (SDLY 0:15)	0:01
10	110°F (43°C) Fill to Low Level	5:00
11	Supply 3 and 4 (Display: "SI")	0:30
12	Wash 1	4:00
13	Drain 1	1:00
14	High Spin 3 (SDLY 0:45)	4:00

## Programming

<b>Cycle 05</b> <b>Hotels and Motels</b> <b>(Towels, light soil, no bleach, cotton)</b>		
Step	Description	Min:sec
1	Hot Fill to Low Level	5:00
2	Supply 1	0:45
3	Wash 1	7:00
4	Wash Drain	0:30
5	Hot Fill to High Level	5:00
6	Wash 1	2:00
7	Drain 5	1:00
8	Warm Spray Rinse	2:00
9	Medium Spin (SDLY 0:15)	0:01
10	110°F (43°C) Fill to Low Level	5:00
11	Supply 3 and 4 (Display: "SI")	0:30
12	Wash 1	4:00
13	Drain 1	1:00
14	High Spin 3 (SDLY 0:45)	4:00

<b>Cycle 06</b> <b>Hotels and Motels</b> <b>(Sheets, medium soil, cotton/poly blends)</b>		
Step	Description	Min:sec
1	Hot Fill to Low Level	5:00
2	Supply 1	0:45
3	Wash 1	6:00
4	Wash Drain	0:30
5	Hot Fill to Low Level	5:00
6	Supply 2	0:45
7	Wash 1	6:00
8	Wash Drain	0:30
9	Hot Fill to High Level	5:00
10	Wash 1	2:00
11	Drain 5	1:00
12	Warm Spray Rinse	2:00
13	Medium Spin (SDLY 0:15)	0:01
14	100°F (38°C) Fill to Low Level	5:00
15	Supply 3 and 4 (Display: "SI")	0:30
16	Wash 1	4:00
17	Drain 1	1:00
18	High Spin 3 (SDLY 0:45)	2:00

<b>Cycle 07 Hotels and Motels (Towels, medium soil, cotton)</b>		
<b>Step</b>	<b>Description</b>	<b>Min:sec</b>
1	Hot Fill to Low Level	5:00
2	Supply 1	0:45
3	Wash 1	6:00
4	Wash Drain	0:30
5	Hot Fill to Low Level	5:00
6	Supply 2	0:45
7	Wash 1	6:00
8	Wash Drain	0:30
9	Hot Fill to High Level	5:00
10	Wash 1	2:00
11	Drain 5	1:00
12	Warm Spray Rinse	2:00
13	Medium Spin (SDLY 0:15)	0:01
14	110°F (43°C) Fill to Low Level	5:00
15	Supply 3 and 4 (Display: "SI")	0:30
16	Wash 1	4:00
17	Drain 1	1:00
18	High Spin 3 (SDLY 0:45)	2:00

<b>Cycle 08 Hotels and Motels (Blankets, spreads, no bleach)</b>		
<b>Step</b>	<b>Description</b>	<b>Min:sec</b>
1	Warm Fill to High Level	5:00
2	Supply 1	0:45
3	Wash 1	6:00
4	Wash Drain	0:45
5	Warm Fill to High Level	5:00
6	Wash 1	5:00
7	Drain 5	1:00
8	Warm Spray Rinse	2:00
9	Medium Spin (SDLY 0:15)	0:01
10	Warm Fill to Low Level	5:00
11	Supply 3 and 4 (Display: "SI")	0:30
12	Wash 1	4:00
13	Drain 1	1:00
14	High Spin 3 (SDLY 0:45)	4:00

**Programming**

<b>Cycle 09 Hotels and Motels (Blankets, spreads, cold water)</b>		
<b>Step</b>	<b>Description</b>	<b>Min:sec</b>
1	Cold Fill to High Level	5:00
2	Supply 1	0:45
3	Wash 1	6:00
4	Wash Drain	0:45
5	Cold Fill to High Level	5:00
6	Wash 1	1:30
7	Drain 5	1:00
8	Cold Spray Rinse	1:30
9	Medium Spin (SDLY 0:15)	0:30
10	Cold Fill to High Level	5:00
11	Supply 3 and 4 (Display: "SI")	0:30
12	Wash 1	4:00
13	Drain 1	1:00
14	High Spin 3 (SDLY 0:00)	4:00

<b>Cycle 10 Hotels and Motels (Towels, heavy soil, cotton)</b>		
<b>Step</b>	<b>Description</b>	<b>Min:sec</b>
1	Hot Fill to Low Level	5:00
2	Supply 1	0:45
3	Wash 1	7:00
4	Hot Fill to High Level	5:00
5	Supply 2	1:00
6	Wash 1	7:00
7	Drain 5	1:00
8	Warm Spray Rinse	3:00
9	Medium Spin (SDLY 0:15)	0:01
10	Warm Fill to High Level	5:00
11	Wash 1	2:00
12	Drain 5	1:00
13	Medium Spin	0:30
14	Warm Fill to Low Level	5:00
15	Supply 3 and 4 (Display: "SI")	1:00
16	Wash 1	4:00
17	Drain 1	1:00
18	High Spin 3 (SDLY 0:00)	5:00

<b>Cycle 11 Hotels and Motels (Rinse and spin only)</b>		
Step	Description	Min:sec
1	Warm Fill to Low Level	5:00
2	Wash 1	1:00
3	Drain 1	1:00
4	Warm Spray Rinse	1:00
5	High Spin 3 (SDLY 0:00)	4:00

<b>Cycle 12 Healthcare (Sheets, light soil, cotton/poly blends)</b>		
Step	Description	Min:sec
1	Warm Fill to High Level	5:00
2	Wash 1	2:00
3	Wash Drain	0:45
4	Hot Fill to Low Level	5:00
5	Supply 1 and 2 (Display: "SA")	0:45
6	Wash 1	8:00
7	Wash Drain	0:30
8	Hot Fill to High Level	5:00
9	Wash 1	3:00
10	Drain 5	1:00
11	Warm Spray Rinse	2:00
12	Medium Spin (SDLY 0:15)	0:01
13	100°F (38°C) Fill to Low Level	5:00
14	Supply 3 and 4 (Display: "SI")	0:30
15	Wash 1	4:00
16	Drain 1	1:00
17	High Spin 3 (SDLY 0:00)	4:00

## Programming

<b>Cycle 13 Healthcare (Towels, light soil, cotton)</b>		
Step	Description	Min:sec
1	Warm Fill to High Level	5:00
2	Wash 1	2:00
3	Wash Drain	0:45
4	Hot Fill to Low Level	5:00
5	Supply 1 and 2 (Display: "SA")	0:45
6	Wash 1	8:00
7	Wash Drain	0:30
8	Hot Fill to High Level	5:00
9	Wash 1	3:00
10	Drain 5	1:00
11	Warm Spray Rinse	2:00
12	Medium Spin (SDLY 0:15)	0:01
13	110°F (43°C) Fill to Low Level	5:00
14	Supply 3 and 4 (Display: "SI")	0:30
15	Wash 1	4:00
16	Drain 1	1:00
17	High Spin 3 (SDLY 0:00)	4:00

<b>Cycle 14 Healthcare (Sheets, heavy soil, cotton/poly blends)</b>		
Step	Description	Min:sec
1	80°F (27°C) Fill to High Level	5:00
2	Wash 1	2:00
3	Wash Drain	0:45
4	120°F (48°C) Fill to High Level	5:00
5	Wash 1	2:00
6	Wash Drain	0:45
7	Hot Fill to Low Level	5:00
8	Supply 1	0:45
9	Wash 1	7:00
10	Wash Drain	0:30
11	Hot Fill to Low Level	5:00
12	Supply 2	0:45
13	Wash 1	7:00
14	Wash Drain	0:30
15	Hot Fill to High Level	5:00
16	Wash 1	3:00
17	Drain 5	1:00
18	Warm Spray Rinse	2:00
19	Medium Spin (SDLY 0:15)	0:01
20	100°F (38°C) Fill to Low Level	5:00
21	Supply 3 and 4 (Display: "SI")	0:30
22	Wash 1	4:00
23	Drain 1	1:00
24	High Spin 3 (SDLY 0:00)	2:00



<b>Cycle 15 Healthcare (Towels, heavy soil, cotton)</b>		
Step	Description	Min:sec
1	80°F (27°C) Fill to High Level	5:00
2	Wash 1	2:00
3	Wash Drain	0:45
4	120°F (48°C) Fill to High Level	5:00
5	Wash 1	2:00
6	Wash Drain	0:45
7	Hot Fill to Low Level	5:00
8	Supply 1	0:45
9	Wash 1	7:00
10	Wash Drain	0:30
11	Hot Fill to Low Level	5:00
12	Supply 2	0:45
13	Wash 1	7:00
14	Wash Drain	0:30
15	Hot Fill to High Level	5:00
16	Wash 1	3:00
17	Drain 5	1:00
18	Warm Spray Rinse	2:00
19	Medium Spin (SDLY 0:15)	0:01
20	110°F (43°C) Fill to Low Level	5:00
21	Supply 3 and 4 (Display: "SI")	0:30
22	Wash 1	4:00
23	Drain 1	1:00
24	High Spin 3 (SDLY 0:00)	4:00

<b>Cycle 16 Healthcare (Thermal blankets, bleach, cotton)</b>		
Step	Description	Min:sec
1	110°F (43°C) Fill to High Level	5:00
2	Wash 1	2:00
3	Wash Drain	0:45
4	Hot Fill to Low Level	5:00
5	Supply 1 and 2 (Display: "SA")	0:45
6	Wash 1	7:00
7	Wash Drain	0:30
8	Hot Fill to High Level	5:00
9	Wash 1	3:00
10	Drain 5	1:00
11	Warm Spray Rinse	2:00
12	Medium Spin (SDLY 0:15)	0:01
13	110°F (43°C) Fill to Low Level	5:00
14	Supply 3 and 4 (Display: "SI")	0:30
15	Wash 1	4:00
16	Drain 1	1:00
17	High Spin 3 (SDLY 0:00)	4:00

## Programming

<b>Cycle 17 Healthcare (Diapers, pads, heavy soil, cotton)</b>		
Step	Description	Min:sec
1	80°F (27°C) Fill to High Level	5:00
2	Wash 1	2:00
3	Wash Drain	0:45
4	Hot Fill to High Level	5:00
5	Wash 1	2:00
6	Wash Drain	0:45
7	Hot Fill to Low Level	5:00
8	Supply 1	0:45
9	Wash 1	7:00
10	Wash Drain	0:30
11	Hot Fill to Low Level	5:00
12	Supply 1	0:30
13	Wash 1	7:00
14	Wash Drain	0:30
15	Hot Fill to Low Level	5:00
16	Supply 2	0:30
17	Wash 1	7:00
18	Wash Drain	0:30
19	Hot Fill to High Level	5:00
20	Wash 1	4:00
21	Drain 5	1:00
22	Warm Spray Rinse	2:00
23	Medium Spin (SDLY 0:15)	0:01
24	110°F (43°C) Fill to High Level	5:00
25	Wash 1	2:00
26	Wash Drain	0:45
27	110°F (43°C) Fill to Low Level	5:00
28	Supply 3 and 4 (Display: "SI")	0:30
29	Wash 1	4:00
30	Drain 1	1:00
31	Medium Spin	1:00
32	High Spin 3 (SDLY 0:45)	4:00

<b>Cycle 18 Healthcare (Personals, bleach)</b>		
Step	Description	Min:sec
1	Hot Fill to Low Level	5:00
2	Supply 1 and 2 (Display: "SA")	0:45
3	Wash 1	6:00
4	Wash Drain	0:30
5	Hot Fill to High Level	5:00
6	Wash 1	2:00
7	Drain 5	1:00
8	Warm Spray Rinse	2:00
9	Medium Spin (SDLY 0:15)	0:01
10	110°F (43°C) Fill to Low Level	5:00
11	Supply 3 and 4 (Display: "SI")	0:30
12	Wash 1	4:00
13	Drain 1	1:00
14	High Spin 3 (SDLY 0:00)	3:00

<b>Cycle 19 Healthcare (Personals, no bleach)</b>		
<b>Step</b>	<b>Description</b>	<b>Min:sec</b>
1	Hot Fill to Low Level	5:00
2	Supply 1	0:45
3	Wash 1	6:00
4	Wash Drain	0:30
5	110°F (43°C) Fill to High Level	5:00
6	Wash 1	2:00
7	Drain 5	1:00
8	Warm Spray Rinse	2:00
9	Medium Spin (SDLY 0:15)	0:01
10	110°F (43°C) Fill to Low Level	5:00
11	Supply 3 and 4 (Display: "SI")	0:30
12	Wash 1	4:00
13	Drain 1	1:00
14	High Spin 3 (SDLY 0:45)	3:00

<b>Cycle 20 Restaurants (Pads, polyester)</b>		
<b>Step</b>	<b>Description</b>	<b>Min:sec</b>
1	110°F (43°C) Fill to Low Level	5:00
2	Supply 1	0:45
3	Wash 1	3:00
4	130°F (54°C) Fill to High Level	5:00
5	Wash 1	2:00
6	Wash Drain	0:45
7	Warm Flush	2:00
8	Hot Fill to Low Level	5:00
9	Supply 1	0:45
10	Wash 1	7:00
11	Wash Drain	0:30
12	Hot Fill to Low Level	5:00
13	Supply 2	0:45
14	Wash 1	7:00
15	Drain 5	1:00
16	Medium Spin (SDLY 0:15)	1:00
17	110°F (43°C) Fill to High Level	5:00
18	Wash 1	2:00
19	Drain 5	1:00
20	Warm Spray Rinse	2:00
21	Medium Spin (SDLY 0:15)	0:01
22	110°F (43°C) Fill to Low Level	5:00
23	Supply 3	0:30
24	Wash 1	3:00
25	Drain 1	1:00
26	High Spin 3 (SDLY 0:45)	4:00

## Programming

<b>Cycle 21</b> <b>Restaurants</b> <b>(Table napery, bleach, starch, iron)</b>		
Step	Description	Min:sec
1	110°F (43°C) Fill to High Level	5:00
2	Wash 1	2:00
3	Wash Drain	0:45
4	Hot Fill to Low Level	5:00
5	Supply 1	0:45
6	Wash 1	7:00
7	Wash Drain	0:30
8	Hot Fill to Low Level	5:00
9	Supply 2	0:45
10	Wash 1	7:00
11	Wash Drain	0:30
12	Hot Fill to High Level	5:00
13	Wash 1	3:00
14	Drain 5	1:00
15	Warm Spray Rinse	2:00
16	Medium Spin (SDLY 0:15)	0:01
17	110°F (43°C) Fill to Low Level	5:00
18	Supply 3	0:30
19	Wash 1	2:00
20	Supply 5	0:30
21	Wash 1	5:00
22	Drain 1	1:00
23	High Spin 3 (SDLY 0:45)	4:00

<b>Cycle 22</b> <b>Restaurants</b> <b>(Table napery, bleach, no iron)</b>		
Step	Description	Min:sec
1	110°F (43°C) Fill to High Level	5:00
2	Wash 1	2:00
3	Wash Drain	0:45
4	Hot Fill to Low Level	5:00
5	Supply 1	0:45
6	Wash 1	7:00
7	Wash Drain	0:30
8	Hot Fill to Low Level	5:00
9	Supply 2	0:45
10	Wash 1	7:00
11	Wash Drain	0:30
12	Hot Fill to High Level	5:00
13	Wash 1	3:00
14	Drain 5	1:00
15	Warm Spray Rinse	2:00
16	Medium Spin (SDLY 0:15)	0:01
17	110°F (43°C) Fill to Low Level	5:00
18	Supply 3 and 4 (Display: "SI")	0:30
19	Wash 1	4:00
20	Drain 1	1:00
21	High Spin 1 (SDLY 0:00)	4:00

<b>Cycle 23 Restaurants (Table napery, colors, starch, iron)</b>		
<b>Step</b>	<b>Description</b>	<b>Min:sec</b>
1	110°F (43°C) Fill to High Level	5:00
2	Wash 1	2:00
3	Wash Drain	0:45
4	Hot Fill to Low Level	5:00
5	Supply 1	0:45
6	Wash 1	7:00
7	Wash Drain	0:30
8	Hot Fill to Low Level	5:00
9	Supply 1	0:45
10	Wash 1	7:00
11	Wash Drain	0:45
12	Hot Fill to High Level	5:00
13	Wash 1	3:00
14	Drain 5	1:00
15	Warm Spray Rinse	2:00
16	Medium Spin (SDLY 0:15)	0:01
17	110°F (43°C) Fill to Low Level	5:00
18	Supply 3	0:30
19	Wash 1	4:00
20	Supply 5	0:30
21	Wash 1	5:00
22	Drain 1	1:00
23	High Spin 3 (SDLY 0:00)	4:00

<b>Cycle 24 Restaurants (Table napery, colors, no iron)</b>		
<b>Step</b>	<b>Description</b>	<b>Min:sec</b>
1	110°F (43°C) Fill to High Level	5:00
2	Wash 1	2:00
3	Wash Drain	0:45
4	Hot Fill to Low Level	5:00
5	Supply 1	0:45
6	Wash 1	7:00
7	Wash Drain	0:30
8	Hot Fill to Low Level	5:00
9	Supply 1	0:45
10	Wash 1	7:00
11	Wash Drain	0:30
12	Hot Fill to High Level	5:00
13	Wash 1	3:00
14	Drain 5	1:00
15	Warm Spray Rinse	2:00
16	Medium Spin (SDLY 0:15)	0:01
17	110°F (43°C) Fill to Low Level	5:00
18	Supply 3 and 4 (Display: "SI")	0:30
19	Wash 1	4:00
20	Drain 1	1:00
21	High Spin 1 (SDLY 0:00)	4:00

## Programming

<b>Cycle 25</b> <b>Restaurants</b> <b>(Visa table napery, bleach, starch, iron)</b>		
Step	Description	Min:sec
1	110°F (43°C) Fill to High Level	5:00
2	Wash 1	3:00
3	Wash Drain	0:45
4	Hot Fill to Low Level	5:00
5	Supply 1	0:45
6	Wash 1	7:00
7	Wash Drain	0:30
8	Hot Fill to Low Level	5:00
9	Supply 2	0:45
10	Wash 1	7:00
11	Wash Drain	0:30
12	Hot Fill to High Level	5:00
13	Wash 1	3:00
14	Drain 5	1:00
15	Warm Spray Rinse	2:00
16	Medium Spin (SDLY 0:15)	0:01
17	110°F (43°C) Fill to High Level	5:00
18	Wash 1	2:00
19	Wash Drain	0:45
20	110°F (43°C) Fill to Low Level	5:00
21	Supply 3	0:30
22	Wash 1	2:00
23	Supply 5	0:30
24	Wash 1	5:00
25	Drain 1	1:00
26	High Spin 3 (SDLY 0:00)	3:00

<b>Cycle 26</b> <b>Restaurants</b> <b>(Visa table napery, bleach, no iron)</b>		
Step	Description	Min:sec
1	110°F (43°C) Fill to High Level	5:00
2	Wash 1	3:00
3	Wash Drain	0:45
4	Hot Fill to Low Level	5:00
5	Supply 1	0:45
6	Wash 1	7:00
7	Wash Drain	0:30
8	Hot Fill to Low Level	5:00
9	Supply 2	0:45
10	Wash 1	7:00
11	Wash Drain	0:30
12	Hot Fill to High Level	5:00
13	Wash 1	3:00
14	Drain 5	1:00
15	Warm Spray Rinse	2:00
16	Medium Spin (SDLY 0:15)	0:01
17	110°F (43°C) Fill to High Level	5:00
18	Wash 1	2:00
19	Wash Drain	0:45
20	110°F (43°C) Fill to Low Level	5:00
21	Supply 3	0:30
22	Wash 1	4:00
23	Drain 1	1:00
24	High Spin 1 (SDLY 0:00)	2:00

<b>Cycle 27</b> <b>Restaurants</b> <b>(Visa table napery, colors, starch, iron)</b>		
Step	Description	Min:sec
1	110°F (43°C) Fill to High Level	5:00
2	Wash 1	3:00
3	Wash Drain	0:45
4	Hot Fill to Low Level	5:00
5	Supply 1	0:45
6	Wash 1	7:00
7	Wash Drain	0:30
8	Hot Fill to Low Level	5:00
9	Supply 1	0:45
10	Wash 1	7:00
11	Wash Drain	0:30
12	Hot Fill to High Level	5:00
13	Wash 1	3:00
14	Drain 5	1:00
15	Warm Spray Rinse	2:00
16	Medium Spin (SDLY 0:15)	0:01
17	110°F (43°C) Fill to High Level	5:00
18	Wash 1	2:00
19	Wash Drain	0:45
20	110°F (43°C) Fill to Low Level	5:00
21	Supply 3	0:30
22	Wash 1	2:00
23	Supply 5	0:30
24	Wash 1	4:00
25	Drain 1	1:00
26	High Spin 3 (SDLY 0:00)	3:00

<b>Cycle 28</b> <b>Restaurants</b> <b>(Visa table napery, colors, no iron)</b>		
Step	Description	Min:sec
1	110°F (43°C) Fill to High Level	5:00
2	Wash 1	3:00
3	Wash Drain	0:45
4	Hot Fill to Low Level	5:00
5	Supply 1	0:45
6	Wash 1	7:00
7	Wash Drain	0:30
8	Hot Fill to Low Level	5:00
9	Supply 1	0:45
10	Wash 1	7:00
11	Wash Drain	0:30
12	Hot Fill to High Level	5:00
13	Wash 1	3:00
14	Drain 5	1:00
15	Warm Spray Rinse	2:00
16	Medium Spin (SDLY 0:15)	0:01
17	110°F (43°C) Fill to High Level	5:00
18	Wash 1	2:00
19	Wash Drain	0:45
20	110°F (43°C) Fill to Low Level	5:00
21	Supply 3	0:30
22	Wash 1	4:00
23	Drain 1	1:00
24	High Spin 1 (SDLY 0:00)	2:00

**Programming**

<b>Cycle 29                      Shirt Laundries                      (Shirts, colors, no bleach, starch)</b>		
<b>Step</b>	<b>Description</b>	<b>Min:sec</b>
1	Hot Fill to Low Level	5:00
2	Supply 1	0:45
3	Wash 1	7:00
4	Wash Drain	0:30
5	Hot Fill to Low Level	5:00
6	Supply 1	0:45
7	Wash 1	5:00
8	Wash Drain	0:30
9	Hot Fill to High Level	5:00
10	Wash 1	3:00
11	Drain 5	1:00
12	Warm Spray Rinse	2:00
13	Medium Spin (SDLY 0:15)	0:01
14	Cold Fill to High Level	5:00
15	Supply 3	0:30
16	Supply 5	0:30
17	Wash 1	4:00
18	Drain 1	1:00
19	High Spin 3 (SDLY 0:00)	4:00

<b>Cycle 30                      Shirt Laundries                      (Shirts, bleach, starch)</b>		
<b>Step</b>	<b>Description</b>	<b>Min:sec</b>
1	Hot Fill to Low Level	5:00
2	Supply 1	0:45
3	Wash 1	7:00
4	Wash Drain	0:30
5	Hot Fill to Low Level	5:00
6	Supply 2	0:45
7	Wash 1	7:00
8	Wash Drain	0:30
9	Hot Fill to High Level	5:00
10	Wash 1	3:00
11	Drain 5	1:00
12	Warm Spray Rinse	2:00
13	Medium Spin (SDLY 0:15)	0:01
14	Cold Fill to High Level	5:00
15	Supply 3	0:30
16	Supply 5	0:30
17	Wash 1	4:00
18	Drain 1	1:00
19	High Spin 3 (SDLY 0:00)	4:00



<b>Cycle 31</b> <b>Shirt Laundries</b> <b>(Shirts, colored, no bleach, no starch)</b>		
Step	Description	Min:sec
1	Hot Fill to Low Level	5:00
2	Supply 1	0:45
3	Wash 1	7:00
4	Wash Drain	0:30
5	Hot Fill to Low Level	5:00
6	Supply 1	0:45
7	Wash 1	5:00
8	Wash Drain	0:30
9	Hot Fill to High Level	5:00
10	Wash 1	3:00
11	Drain 5	1:00
12	Warm Spray Rinse	2:00
13	Medium Spin (SDLY 0:15)	0:01
14	Cold Fill to High Level	5:00
15	Supply 3	0:30
16	Supply 4	0:30
17	Wash 1	4:00
18	Drain 1	1:00
19	High Spin 3 (SDLY 0:45)	4:00

<b>Cycle 32</b> <b>Shirt Laundries</b> <b>(Shirts, no bleach, no starch, delicates)</b>		
Step	Description	Min:sec
1	Warm Fill to Low Level	5:00
2	Wash 1	2:00
3	Wash Drain	0:30
4	Warm Fill to Low Level	5:00
5	Supply 1	0:45
6	Wash 1	5:00
7	Wash Drain	0:30
8	Warm Fill to High Level	5:00
9	Wash 1	2:00
10	Wash Drain	0:45
11	Warm Fill to High Level	5:00
12	Wash 1	2:00
13	Wash Drain	0:45
14	Cold Fill to High Level	5:00
15	Supply 3	0:30
16	Supply 4	0:30
17	Wash 1	3:00
18	Drain 1	1:00
19	High Spin 2 (SDLY 0:00)	2:00

## Programming

<b>Cycle 33 Shirt Laundries (Starch, extract only)</b>		
Step	Description	Min:sec
1	Warm Fill to Low Level	5:00
2	Supply 3	0:30
3	Supply 5	0:30
4	Wash 1	7:00
5	Drain 1	1:00
6	High Spin 3 (SDLY 0:00)	4:00

<b>Cycle 34 Formula Common to All Markets (Uniforms, with bleach)</b>		
Step	Description	Min:sec
1	110°F (43°C) Fill to High Level	5:00
2	Wash 1	3:00
3	Wash Drain	0:45
4	Hot Fill to Low Level	5:00
5	Supply 1	0:45
6	Wash 1	7:00
7	Wash Drain	0:30
8	Hot Fill to Low Level	5:00
9	Supply 2	0:45
10	Wash 1	7:00
11	Wash Drain	0:30
12	Hot Fill to High Level	5:00
13	Wash 1	3:00
14	Drain 5	1:00
15	Warm Spray Rinse	2:00
16	Medium Spin (SDLY 0:15)	0:01
17	110°F (43°C) Fill to High Level	5:00
18	Wash 1	2:00
19	Wash Drain	0:45
20	110°F (43°C) Fill to Low Level	5:00
21	Supply 3 and 4 (Display: "SI")	0:30
22	Wash 1	4:00
23	Drain 1	1:00
24	High Spin 3 (SDLY 0:45)	4:00

<b>Cycle 35</b> <b>Formula Common to All Markets</b> <b>(Uniforms, without bleach)</b>		
Step	Description	Min:sec
1	Hot Fill to Low Level	5:00
2	Supply 1	0:45
3	Wash 1	6:00
4	Wash Drain	0:30
5	110°F (43°C) Fill to High Level	5:00
6	Wash 1	2:00
7	Drain 5	1:00
8	Warm Spray Rinse	2:00
9	Medium Spin (SDLY 0:15)	0:01
10	110°F (43°C) Fill to Low Level	5:00
11	Supply 3 and 4 (Display: "SI")	0:30
12	Wash 1	4:00
13	Drain 1	1:00
14	High Spin 3 (SDLY 0:00)	3:00

<b>Cycle 36</b> <b>Formula Common to All Markets</b> <b>(Rags/housekeeping, heavy soil)</b>		
Step	Description	Min:sec
1	110°F (43°C) Fill to High Level	5:00
2	Wash 1	2:00
3	Wash Drain	0:45
4	Hot Fill to Low Level	5:00
5	Supply 1	0:45
6	Wash 1	7:00
7	Wash Drain	0:30
8	Hot Fill to Low Level	5:00
9	Supply 2	0:45
10	Wash 1	7:00
11	Wash Drain	0:30
12	Hot Fill to High Level	5:00
13	Wash 1	2:00
14	Drain 5	1:00
15	Warm Spray Rinse	2:00
16	Medium Spin (SDLY 0:15)	0:01
17	110°F (43°C) Fill to Low Level	5:00
18	Supply 3	0:30
19	Wash 1	4:00
20	Drain 1	1:00
21	High Spin 3 (SDLY 0:00)	4:00

## Programming

<b>Cycle 37</b> <b>Formula Common to All Markets</b> <b>(Rags/kitchen, mops)</b>		
Step	Description	Min:sec
1	110°F (43°C) Fill to High Level	5:00
2	Wash 1	2:00
3	Wash Drain	0:45
4	Hot Fill to Low Level	5:00
5	Supply 1	0:45
6	Wash 1	7:00
7	Wash Drain	0:30
8	Hot Fill to Low Level	5:00
9	Supply 2	0:45
10	Wash 1	7:00
11	Wash Drain	0:30
12	Hot Fill to High Level	5:00
13	Wash 1	2:00
14	Drain 5	1:00
15	Warm Spray Rinse	2:00
16	Medium Spin (SDLY 0:15)	0:01
17	110°F (43°C) Fill to Low Level	5:00
18	Supply 3	0:30
19	Wash 1	4:00
20	Drain 1	1:00
21	High Spin 3 (SDLY 0:00)	4:00

<b>Cycle 38</b> <b>Formula Common to All Markets</b> <b>(Rewash/reclaim)</b>		
Step	Description	Min:sec
1	130°F (54°C) Fill to High Level	5:00
2	Wash 1	2:00
3	Wash Drain	0:45
4	Hot Fill to Low Level	5:00
5	Supply 1 and 2 (Display: "SA")	0:45
6	Wash 1	4:00
7	Wash Drain	0:30
8	Hot Fill to Low Level	5:00
9	Supply 1 and 2 (Display: "SA")	0:45
10	Wash 1	7:00
11	Wash Drain	0:30
12	Hot Fill to High Level	5:00
13	Wash 1	4:00
14	Drain 5	1:00
15	Warm Spray Rinse	2:00
16	Medium Spin (SDLY 0:15)	0:01
17	110°F (43°C) Fill to High Level	5:00
18	Wash 1	2:00
19	Wash Drain	0:45
20	110°F (43°C) Fill to Low Level	5:00
21	Supply 3 and 4 (Display: "SI")	0:30
22	Wash 1	4:00
23	Drain 1	1:00
24	High Spin 3 (SDLY 0:00)	4:00

Cycle 39 (Test)		
Step	Description	Min:sec
1	Cold Fill to Low Level	0:30
2	Drain 1	0:10
3	Hot Fill to Low Level	5:00
4	Heat, 150°F (66°C)	1:00
5	Cold Fill to High Level	5:00
6	Supply 1	0:10
7	Supply 2	0:10
8	Supply 3	0:10
9	Supply 4	0:10
10	Supply 5	0:10
11	Supply 1 and 3 (Display: “SB”)	0:10
12	Wash 2	1:00
13	Wash 3	0:30
14	Wash 4	0:15
15	Wash 1, No Reverse	0:30
16	Wash Drain	0:45
17	Warm Flush	0:30
18	Auxiliary 1	0:05
19	Auxiliary 2	0:05

Cycle 39 (Test) (continued)		
Step	Description	Min:sec
20	Auxiliary 3	0:05
21	150°F (66°C) Fill to High Level	5:00
22	Cold Fill to Overflow	1:00
23	Soak	2:00
24	Drain 1	1:00
25	Medium Spin (SDLY 0:00)	2:00
26	Warm Spray Rinse	0:30
27	High Spin 1 (SDLY 0:00)	2:00
28	High Spin 2 (SDLY 0:00)	2:00
29	High Spin 3 (SDLY 0:45)	2:00
30	Auxiliary 3	0:15
31	Cold Fill to Medium Level	5:00
32	Wash 1	0:15
33	Drain to Reuse Tank A	1:30
34	Fill from Reuse Tank A to High Level	2:00
35	Drain to Reuse Tank B	1:30
36	Fill from Reuse Tank B to High Level	2:00
37	Wash Drain	0:30

**NOTE: Alarm will sound on steps 01 and 02 (of Test Cycle). These steps have been deliberately programmed with times that are too short. Press Start to continue when alarm sounds. Times here are actual operating times if steps are allowed to progress to their end without pressing Advance.**

## Programming

### Sample Cycle for Wet Clean

Sample Wet Clean Cycle		
Step	Description	Min:sec
1	Wash 3 (no agitation)	0:01
2	Cold Fill to Medium Level	5:00
3	Auxiliary 1 (select half wash)	0:01*
4	Auxiliary 2 (Recirculation pump)	0:01*
5	Supply 2	0:08
6	Wash 6, 86°F (30°C)	6:00
7	Wash Drain	0:45
8	Wash 3 (no agitation)	0:01
9	Cold Fill to Medium Level	5:00
10	Auxiliary 1 (half wash speed)	0:01*
11	Auxiliary 2 (Recirculation pump)	0:01*
12	Wash 6	3:00
13	Wash Drain	0:45
14	Wash 3 (no agitation)	0:01
15	Cold Fill to Medium Level	5:00
16	Auxiliary 1 (half wash speed)	0:01*
17	Auxiliary 2 (Recirculation pump)	0:01*
18	Supply 3	0:11
19	Wash 6	3:00
20	Drain 1	1:00
21	High speed extract #2	2:00
22	Wash 3 (no agitation)	0:01
* This setting will remain in effect until next drain step. This includes any agitation settings or auxiliary outputs.		

	<b>WARNING</b>
<p><b>Use of any wet clean cycle prior to approval by a wet clean chemical manufacturer's representative can result in damage to garments.</b></p>	
SW034	